



### Miniature, Slim-styled Type Proximity

- Space-saving prox ideal for timing cam and dog detection
- Four mounting holes provided: two from the side and two from the rear of the housing
- Ganged mounting possible for multiple pulse generation
- Alternate frequency models available to avoid mutual interference



### Ordering Information

Type	Sensing Distance	Part number					
		DC 3-wire switching type				AC switching type	
		NPN-NO	NPN-NC	PNP-NO	PNP-NC	SCR-NO	SCR-NC
Shielded 	2 mm (0.08 in)	<b>TL-T2E1</b>	<b>TL-T2E2</b>	<b>TL-T2F1</b>	<b>TL-T2F2</b>	<b>TL-T2Y1</b>	<b>TL-T2Y2</b>
Unshielded 	5 mm (0.20 in)	<b>TL-T5ME1</b>	<b>TL-T5ME2</b>	<b>TL-T5MF1</b>	<b>TL-T5MF2</b>	<b>TL-T5MY1</b>	<b>TL-T5MY2</b>

- Note: 1. To avoid mutual interference, this sensor can be ordered with a different oscillating frequency. Add a "5" to the end of the part number (e.g. TL-N2E15).
2. Add suffix "G" to the model number when placing your order for European models with color-coded cables conforming to CENELEC standard (EN50044). Refer to the color code table in the "Output Stage Circuit Diagram" for the cable color codes of the European models.

# Specifications

## ■ RATINGS/CHARACTERISTICS

Part number		TL-T2E1, TL-T2E2, TL-T2F1, TL-T2F2	TL-T2Y1, TL-T2Y2	TL-T5ME1, TL-T5ME2, TL-T5MF1, TL-T5MF2	TL-T5MY1, TL-T5MY2
Supply voltage (operating voltage range)		E and F models: 12 to 24 VDC (10 to 30 VDC), ripple (p-p): 20% max. Y models: 100 to 220 VAC (90 to 250 VAC), 50/60 Hz			
Current consumption		E and F models: 15 mA max. at 24 VDC			
Leakage current		Y models: 2.5 mA max. at 200 VAC			
Sensing object		Magnetic metal (The sensing distance decreases with non-magnetic metal.)			
Sensing distance		2 mm $\pm$ 10% (0.08 $\pm$ 10%)		5 mm $\pm$ 10% (0.19 $\pm$ 10%)	
Sensing distance (standard object)		0 to 1.6 mm (iron, 12 x 12 x 1 mm) 0 to 0.06 in (iron 0.47, 47 x 0.04 in)		0 to 4 mm (iron, 15 x 15 x 1 mm) 0 to 0.157 in (iron 0.59 x 0.59 x 0.39 in)	
Differential travel		10% max. of sensing distance			
Response frequency		E and F models: 800 Hz, Y models: 20 Hz		E and F models: 250 Hz, Y models: 20 Hz	
Operating status (with sensing object approaching)		E1 models: L output signal with load ON E2 models: H output signal with load OFF F1 models: H output signal with load ON Y1 models: Load ON Y2 models: Load OFF			
Control output	Type	E1: NPN-NO Y1: SCR-NO E2: NPN-NC Y2: SCR-NC F1: PNP-NO F2: PNP-NC			
	Switching capacity	E and F models: 100 mA max. at 12 VDC and 200 mA max. at 24 VDC Y models: 10 to 200 mA			
Circuit protection		E and F models: Reverse connection protection and surge absorber Y models: Surge absorber			
Indicator		Operation indicator (red LED)			
Ambient temperature	Operating	-25°C to 70°C (-13°F to 158°F) with no icing			
Ambient humidity	Operating	35% to 95%			
Temperature influence		$\pm$ 10% max. of sensing distance at 23°C (73.4°F) in the temperature range of -25°C to 70°C (-13°F to 158°F)			
Voltage influence		E and F models: $\pm$ 2.5% max. of sensing distance within a range of $\pm$ 15% of the rated power supply voltage Y models: $\pm$ 2.5% max. of sensing distance within a range of $\pm$ 10% of the rated power supply voltage			
Residual voltage		E and F models: 1.0 V max. with a load current of 100 mA and a cord length of 2 m Y models: Refer to <i>Residual Load Voltage (Typical)</i> on page 4.			
Insulation resistance		50 M $\Omega$ min. (at 500 VDC) between case and current carry parts			
Dielectric strength		DC switching models: 1,000 VAC, 50/60 Hz for 1 min between case and current carry parts AC switching models: 2,000 VAC, 50/60 Hz for 1 min between case and current carry parts			
Vibration resistance		10 to 55 Hz, 1.5-mm (0.06 in) double amplitude for 2 hours each in X, Y, and Z directions			
Shock resistance		500 m/s <sup>2</sup> (1640 ft/s <sup>2</sup> ) approx. 50G for 10 times each in X, Y, and Z directions			
Enclosure rating		IEC IP67			
Weight (with 2-m cord)		Approx. 70 g (2.47 oz)			
Material	Case	Heat-resistant ABS resin			
	Sensing surface	Heat-resistant ABS resin			

# Operation

## OUTPUT CIRCUITS

### E Models

#### NPN (DC 3-wire)

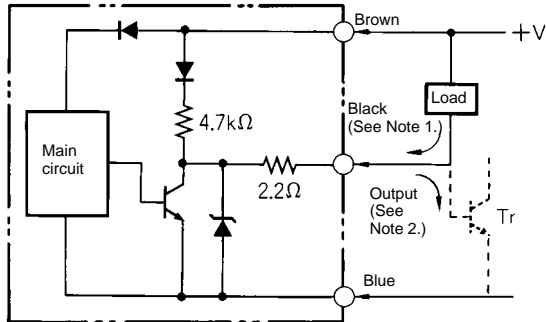

Note: 1. 200 mA max. (load current)  
2. When a transistor is connected

### F Models

#### PNP (DC 3-wire)

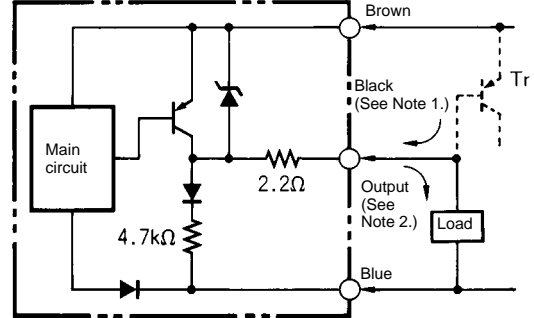

Note: 1. 200 mA max. (load current)  
2. When a transistor is connected

### Y Models

#### (AC 2-wire)

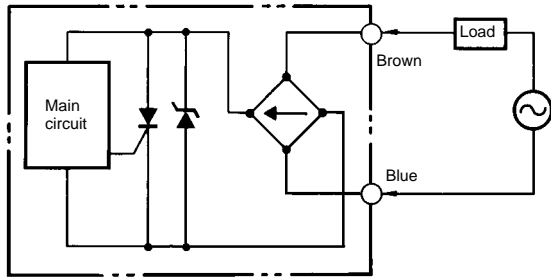

## TIMING CHARTS

### E Models

#### NPN (DC 3-wire)

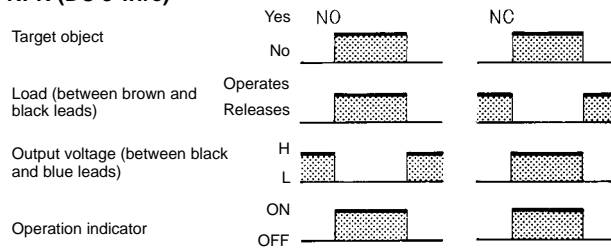

### F Models

#### PNP (DC 3-wire)

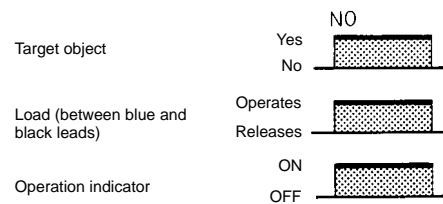

### Y Models

#### (DC 2-wire)

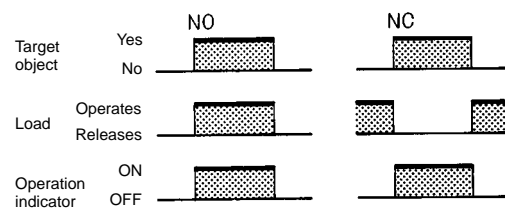

# Engineering Data

## OPERATING RANGE (TYPICAL)

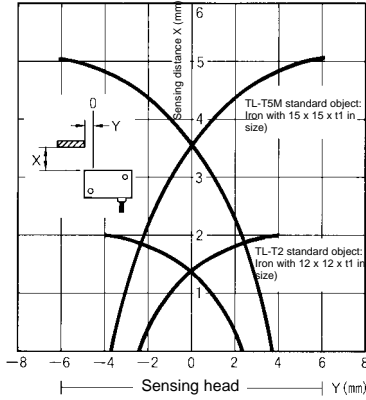

## SENSING OBJECT SIZE AND MATERIAL VS. SENSING DISTANCE (TYPICAL)

TL-T2

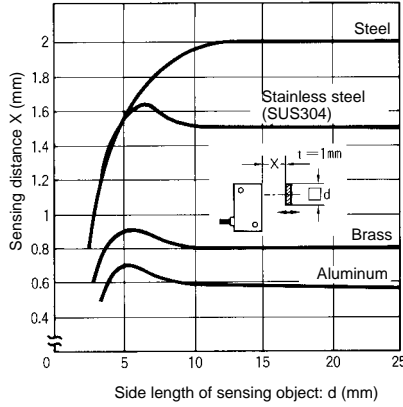

TL-T5M

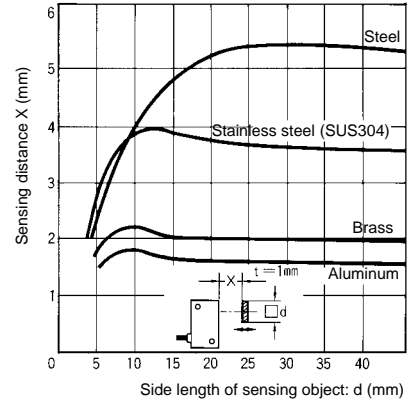

## LEAKAGE CURRENT (TYPICAL)

TL-T□Y

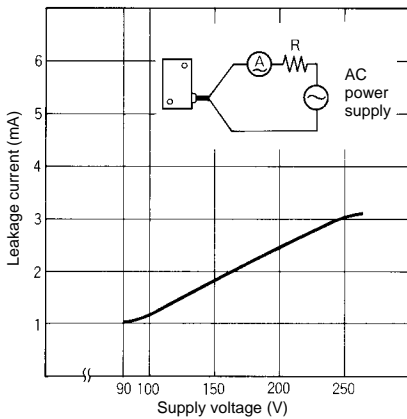

## RESIDUAL LOAD VOLTAGE (TYPICAL)

(at constant 100 VAC)

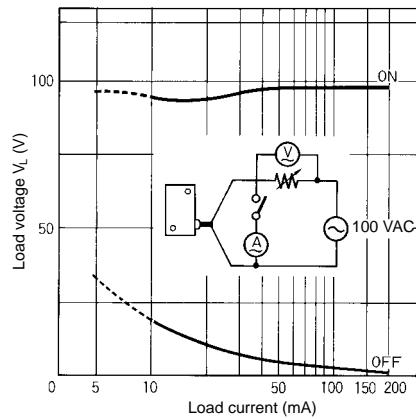

(at constant 200 VAC)

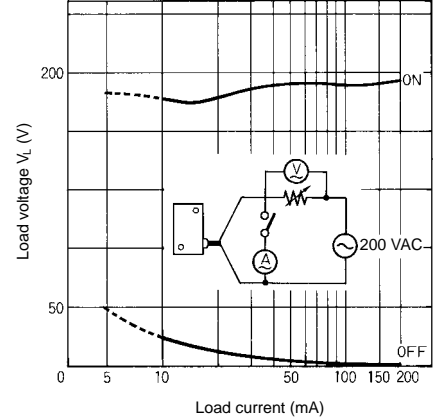

# Dimensions

Unit: mm (inch)

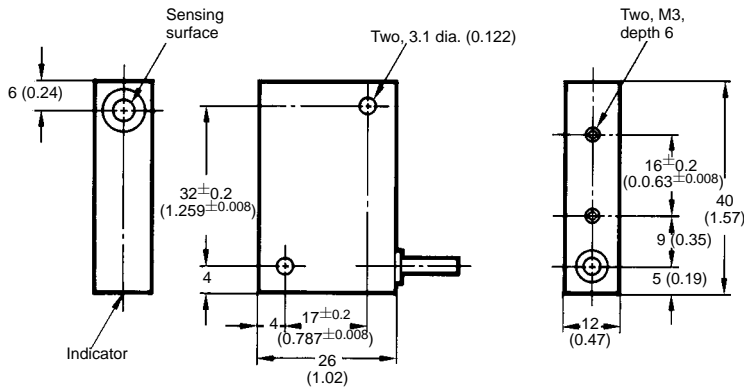

DC switching model: Three, 0.2-mm (0.007 in) conductors  
 AC switching model: Two, 0.3-mm (0.012 in) conductors  
 Oil- and vibration-resistant, vinyl-insulated round cord,  
 4 external dia.; standard length: 2 m (6.56 ft)

# Precautions

## ■ CONNECTION TO THE LOAD

Be sure to connect the Proximity Sensor to the power source through a load. Direct connection of the Sensor may damage the Sensor.

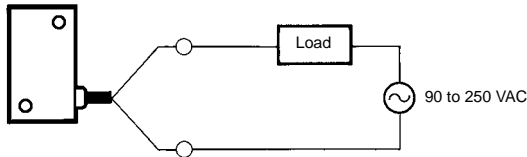

## ■ MOUNTING

At the time of rear mounting, be sure that the tightening torque does not exceed 6 kgf • cm (0.59 N • m) 5.22 in • lbf.

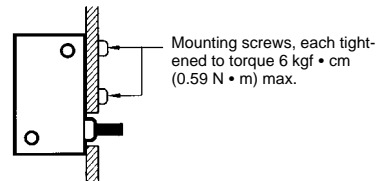

At the time of side mounting, be sure that the tightening torque does not exceed 8 kgf • cm (0.78 N • m) 2.02 in • lbf.

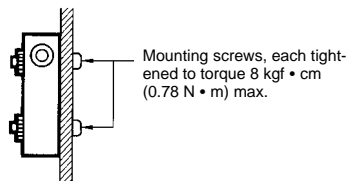

**EFFECT OF SURROUNDING METALS**

If the TL-T5M is embedded in metal, keep at least the following distances between the TL-T and the metal.

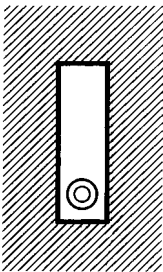
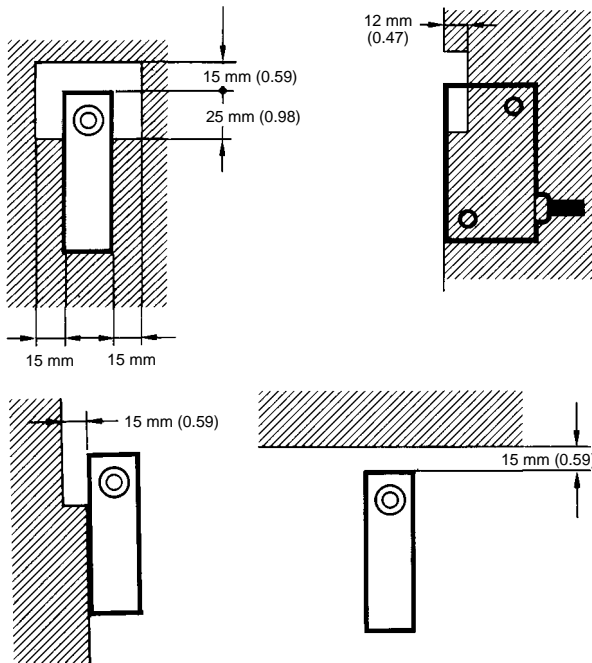

If the TL-T2 is embedded in metal, the TL-T2 will not be influenced by metal.

**MUTUAL INTERFERENCE**

When two or more TL-T sensors are mounted face-to-face or side-by-side, separate them as shown below. The table below indicates the minimum distances A and B.

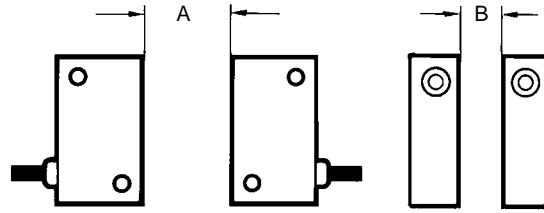

Distance	A	B
TL-T5□□	120 mm (4.72 in)	80 mm (3.15 in)
TL-T5□□5	60 mm (2.36 in)	40 mm (1.57 in)
TL-T2□□	40 mm (1.57 in)	12 mm (0.47 in)
TL-T2□□5	10 mm (0.39 in)	0 mm

Note: Figures in parentheses will apply if the Sensors in use are different from each other in response frequency.

**NOTE: DIMENSIONS SHOWN ARE IN MILLIMETERS. To convert millimeters to inches divide by 25.4.**

**OMRON**<sup>®</sup>  
**OMRON ELECTRONICS, INC.**  
 One East Commerce Drive  
 Schaumburg, IL 60173  
**1-800-55-OMRON**

**OMRON CANADA, INC.**  
 885 Milner Avenue  
 Scarborough, Ontario M1B 5V8  
**416-286-6465**