

Slide Potentiometer > RS**1 Series > RS3011114A02

Series Common Info

Super Slide™ (Standard Type) RS**1 Series

- [Photo](#) | [Dimensions](#) | [Mounting Hole Dimensions](#) | [Terminal Layout / Circuit Diagram](#) |
- [Packing Specifications](#) | [Soldering Conditions](#) |

PRINT

Metal lever

Part number	RS3011114A02	
Number of resistor elements	Single-unit	
Direction of lever	Vertical	
Travel	30mm	
Lever type	4	
Length of lever	15mm	
Total resistance	20kΩ	
Resistance taper	1B	
Detent	Without	
Mounting plate	Without	
Operating temperature range	-25°C to +70°C	
Electrical performance	Total resistance tolerance	±20%
	Maximum operating voltage	200V AC, 10V DC
	Rated power	0.2W
	Insulation resistance	100MΩ min. 250V DC
	Voltage proof	300V AC for 1 minute
Mechanical performance	Operating force	0.3 to 2.5N
	Stopper strength	50N
	Lever push-pull strength	50N
	Lever wobble (Both side)	3mm
	Lever deviation (One side)	0.5mm max.
Durability	Operating life	15,000 cycles

Minimum order unit (pcs.)	Japan	600
	Export	2,400

3D CAD (STEP) [↓](#)

Certificate of Compliance to RoHS regulations [↓](#)

Photo



Dimensions

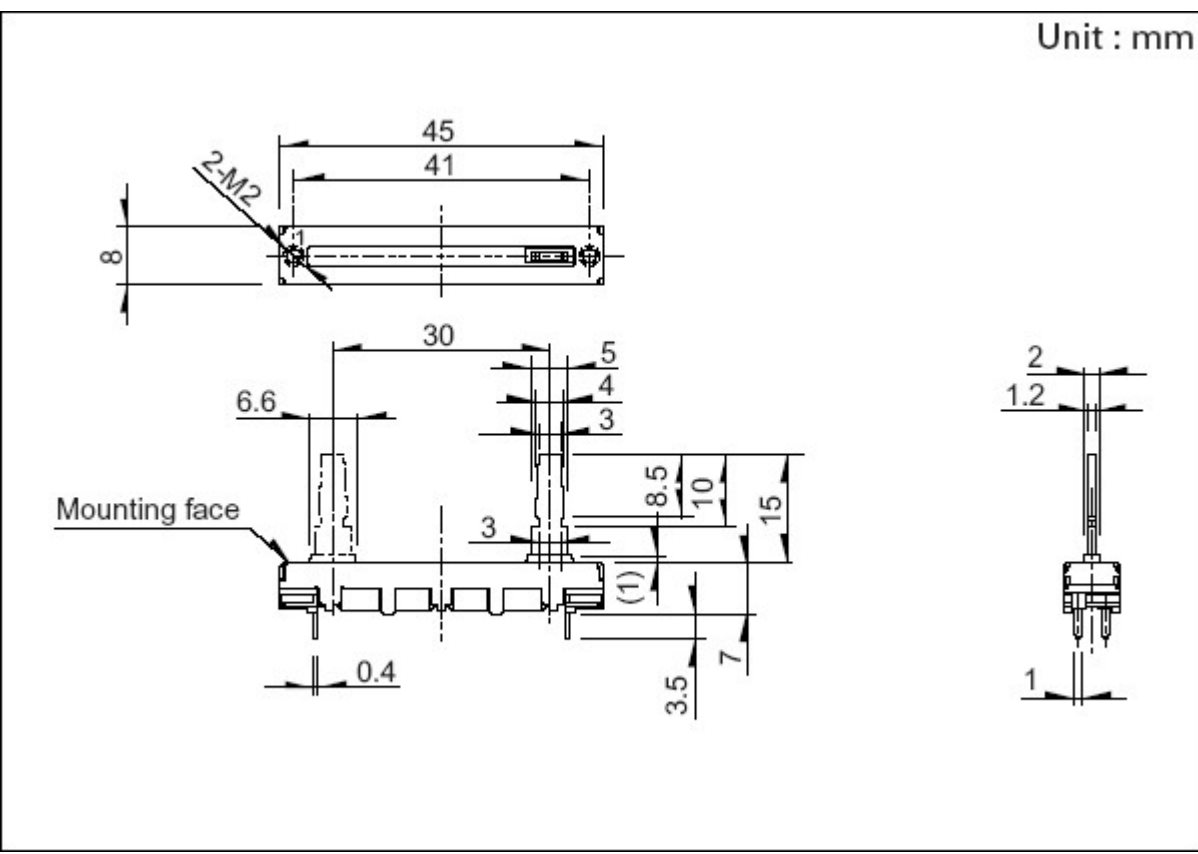

Mounting Hole Dimensions

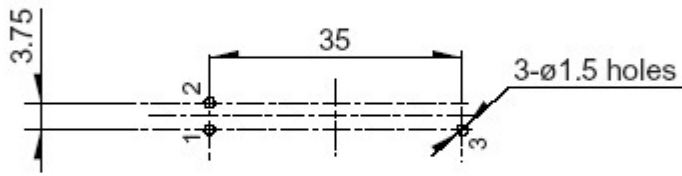

Viewed from mounting side.

Terminal Layout / Circuit Diagram

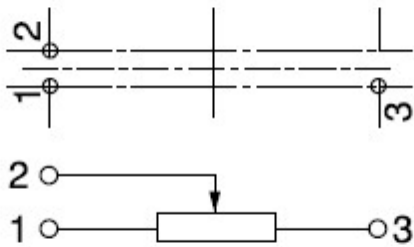

Packing Specifications

Tray

Number of packages (pcs.)	1 case / Japan	600
	1 case / export packing	2,400
Export package measurements (mm)	378×518×422	

Soldering Conditions

Reference for Dip Soldering

Preheating	Soldering surface temperature	100 ℃ max.
	Heating time	1 min. max.
Dip soldering	Soldering temperature	260 ℃ max.
	Soldering time	5s max.
No. of solders		1 time

Reference for Hand Soldering

Tip temperature		350 ℃ max.
Soldering time		3s max.
No. of solders		1 time

Notes are common to this series/models.

1. This site catalog shows only outline specifications. When using the products, please obtain formal specifications for supply.
2. Please place purchase orders per minimum order unit (integer).
3. Products other than those listed in above products are also available. Please contact us for details.
4. "L" in the "Lever Wobble" column of the above table indicates the length of lever.
5. This products can be used in vehicles.
Although these products are designed to perform over a wide operating temperature range, please ensure that you receive and read the formal delivery specifications before use.

Inquiries about Products

 [Inquiry](#)