

With Knob Type RK10J/RK14J Series

- [Photo](#) |
 [Dimensions](#) |
 [Mounting Hole Dimensions](#) |
 [Terminal Layout](#) |
 [Circuit Diagram](#) |
 [Packing Specifications](#) |
 [Soldering Conditions](#)

PRINT

Part number	RK14J12R0A09	
Number of resistor elements	Dual-unit	
Total resistance	10kΩ	
Resistance taper	15C	
Soldering	Reflow	
Type	14mm Size	
Knob types	Outer size: φ15 Knob thickness: t0.9mm Color: Black	
Mounting board types	Surface mounting	
For DC use	Not applicable	
Operating temperature range	-25ℓ to +70ℓ	
Electrical Performance	Total resistance tolerance	±30%
	Rated power	0.03W
	Maximum operating voltage	50V AC
	Maximum attenuation	70dB min.
	Insulation resistance	100MΩ min. 100V DC
	Voltage proof	100V AC for 1 minute
Mechanical Performance	Total rotational angle	270°±5°
	Rotational torque	1 to 10mN·m
	Stopper strength	70mN·m
	Push-pull strength	5N
	Vibration	10 to 55 to 10Hz/min., the amplitude is 1.5mm for all the frequencies, in the 3 direction of X, Y and Z and for 2 hours respectively
Durability	Operating life	10,000 cycles

Minimum order unit (pcs.)	Japan	3,000
	Export	3,000

3D CAD (STEP) [↓](#)

Certificate of Compliance to RoHS regulations [↓](#)

Photo

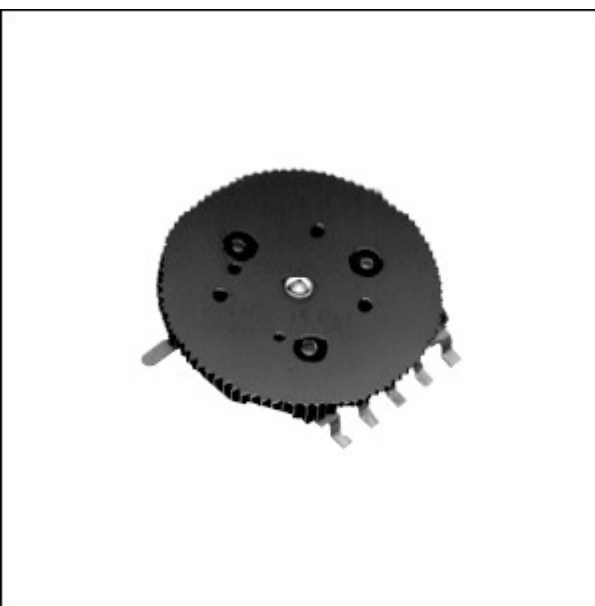

Dimensions

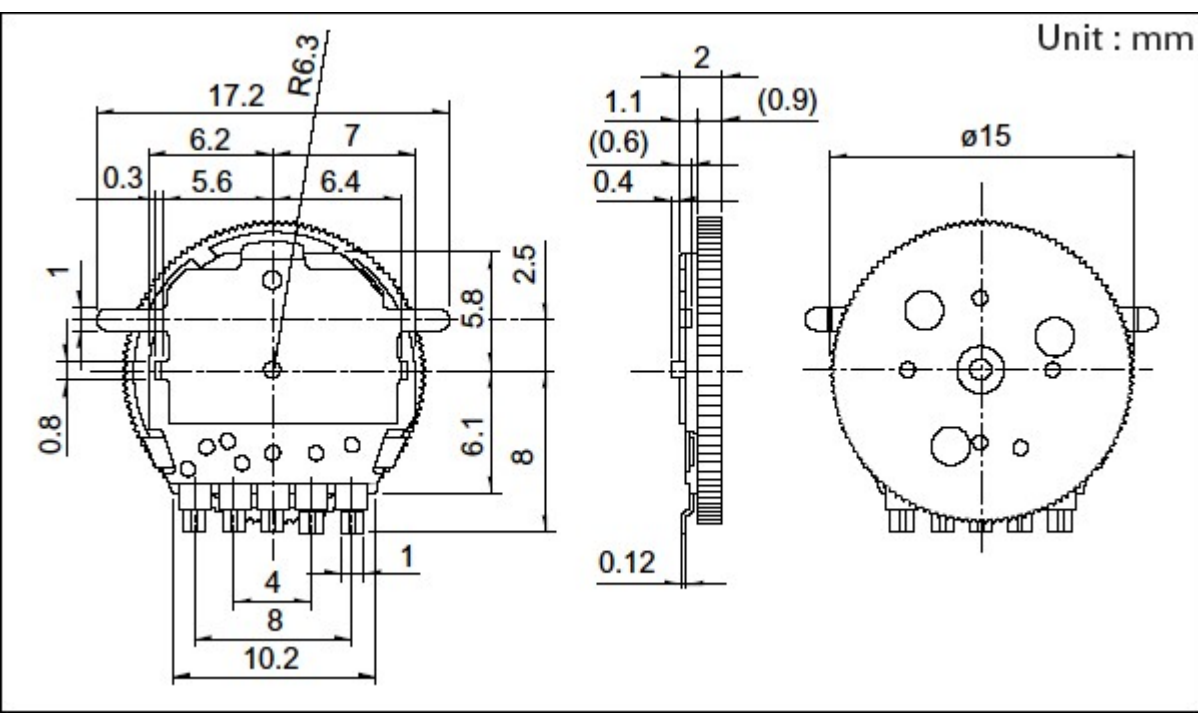

Mounting Hole Dimensions

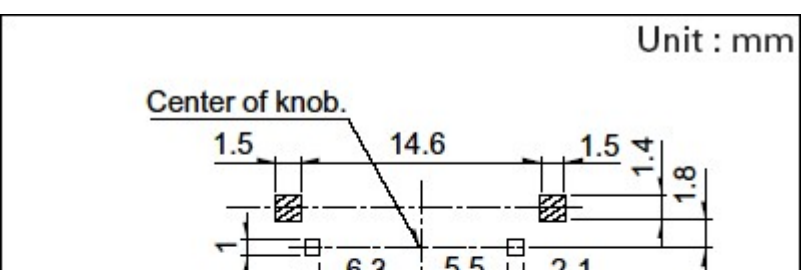

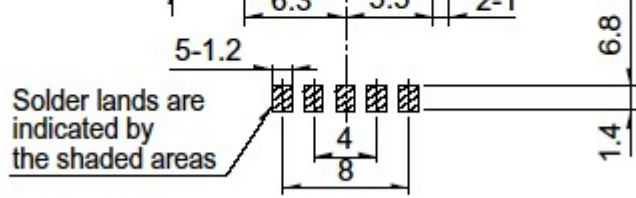

Viewed from mounting side.

Terminal Layout

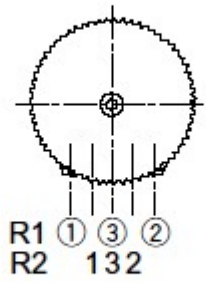

Circuit Diagram

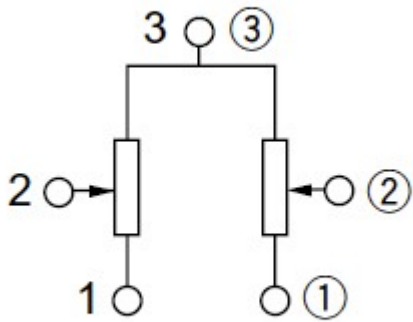

Packing Specifications

Taping

Unit: mm

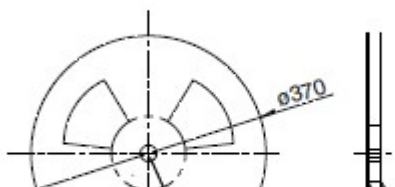

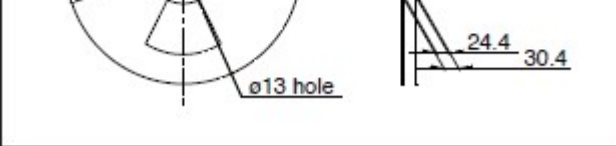

Number of packages (pcs.)	1 reel	1,000
	1 case / Japan	3,000
	1 case / export packing	3,000
Tape width (mm)	24	
Export package measurements (mm)	397×401×139	

Soldering Conditions

Example of Reflow Soldering Condition

1. Heating method

Double heating method with infrared heater.

2. Temperature measurement

Thermocouple 0.1 to 0.2 Φ CA (K) or CC (T) at soldering portion (copper foil surface). A heat resisting tape should be used for fixed measurement.

3. Temperature profile

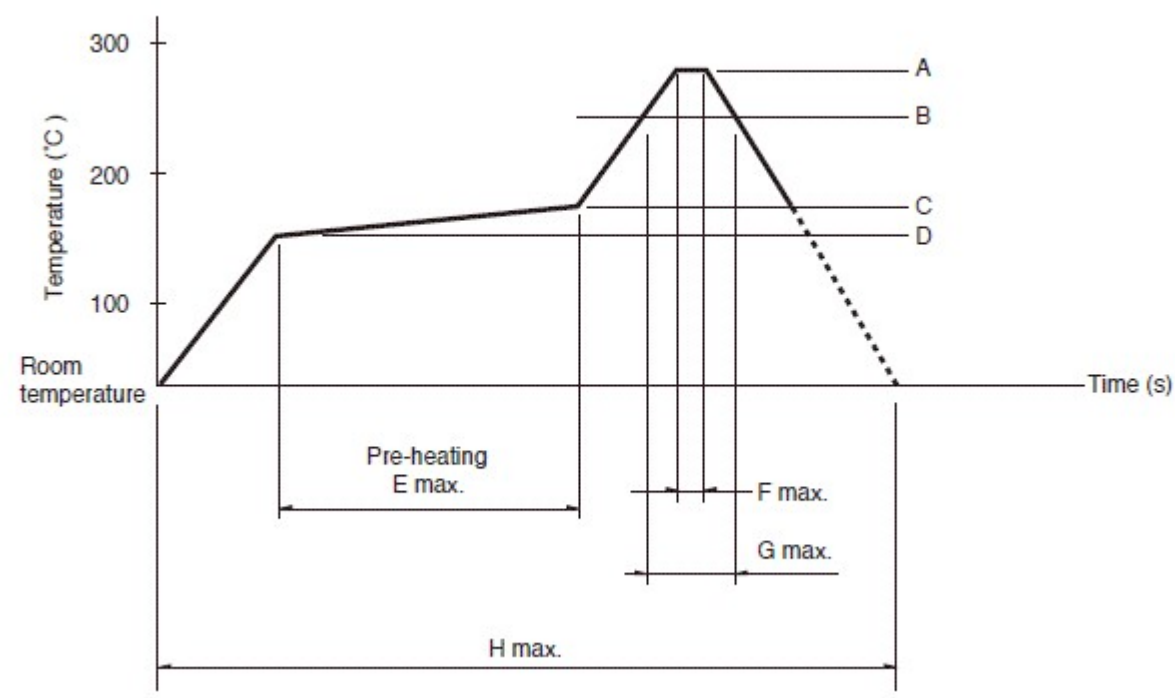

A	B	C	D	E	F	G	H	No. of reflows
250	200	150	150	2 min.	3s	40s	4 min.	2 time max.

1. When using an infrared reflow oven, solder may sometimes not be applied. Be sure to use a hot air reflow oven or a type that uses infrared rays in combination with hot air.

2. The temperatures given above are the maximum temperatures at the terminals of the potentiometer when employing a hot air reflow method. The temperature of the PC board and the surface temperature of the potentiometer may vary greatly depending on the PC board material, its size and thickness. Ensure that the surface temperature of the potentiometer does not rise to 250°C or greater.

3. Conditions vary to some extent depending on the type of reflow bath used. Be sure to give due consideration to this prior to use.

Reference for Hand Soldering

Tip temperature 350 max.

Soldering time

3s max.

No. of solders

1 time

Notes are common to this series/models.

1. This site catalog shows only outline specifications. When using the products, please obtain formal specifications for supply.
2. Please place purchase orders per minimum order unit (integer).
3. Products other than those listed in above products are also available. Please contact us for details.
4. Dip soldering can be applied to RK14J. For dip soldering applications, specify separately as "dip soldering applicable product".

Inquiries about Products

 [Inquiry](#)