

Oct.1.2019 Copyright 2019 HIROSE ELECTRIC CO., LTD. All Rights Reserved.
In case of consideration for using Automotive equipment / device which demand high reliability, kindly contact our sales window correspondents.

COUNT	DESCRIPTION OF REVISIONS	BY	CHKD	DATE	COUNT	DESCRIPTION OF REVISIONS	BY	CHKD	DATE
1	DIS-E-000525	Y.S	H.M	06.06.22					

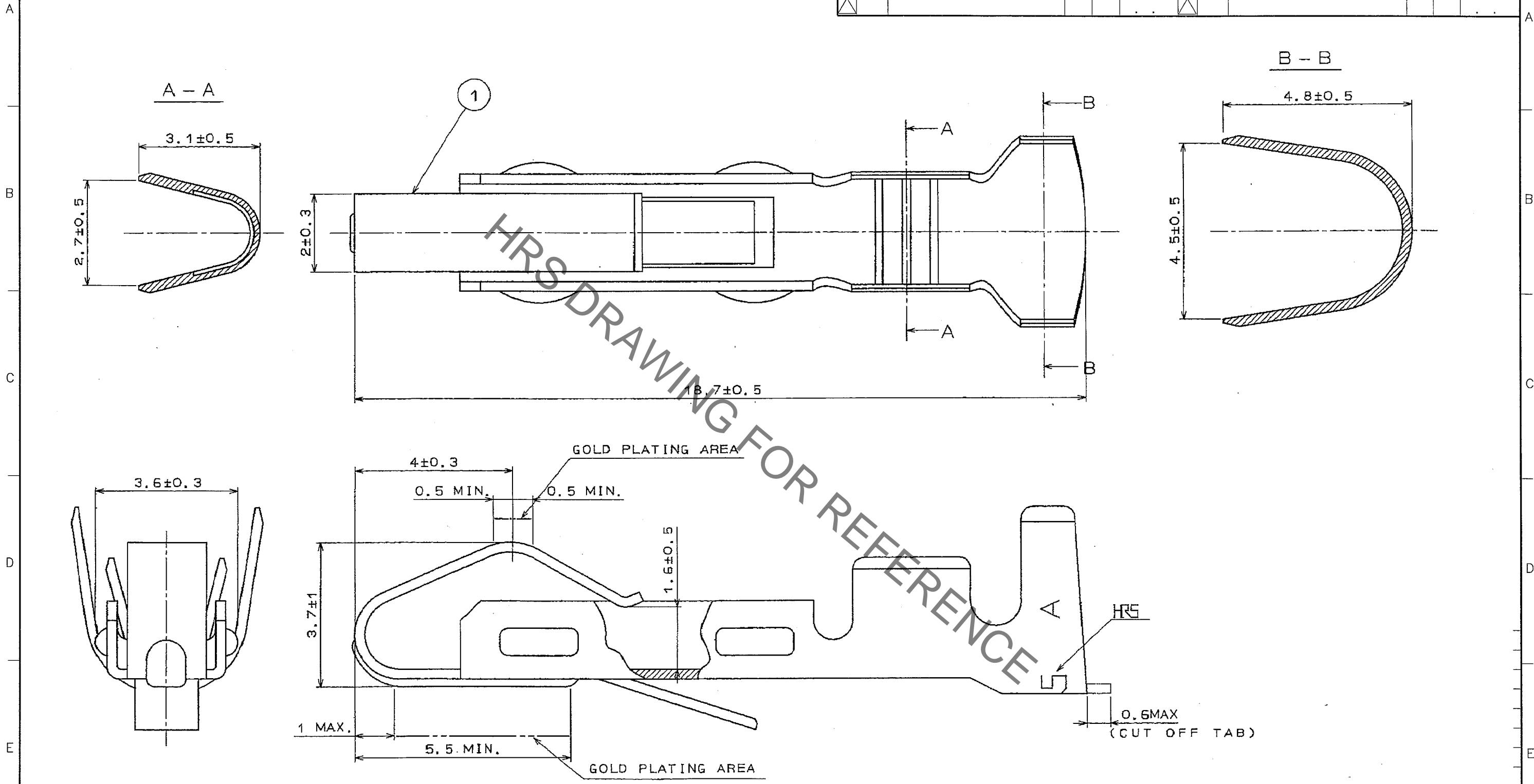

1 TABLE-1

	WIRE SIZE	SAFETY STANDARD		
		UL	CSA	TÜV
CURRENT RATING	AWG#14	10A	10A	10A
	AWG#16	10A	8A Δ	10A

NOTE 1 APPLICABLE WIRE SIZE AND CURRENT RATING ARE AS PER TABLE-1.

1	PHOSPHOR BRONZE	SELECTIVE GOLD PLATING OVER NICKEL PLATING			
NO.	MATERIAL	FINISH, REMARKS	NO.	MATERIAL	FINISH, REMARKS
CODE NO. (OLD)			DRAWN	DESIGNED	CHECKED
			T.WATANABE	T.WATANABE	H.MIWA
			95.08.03	95.08.03	95.08.03
					APPROVED
					S.KIKUTA
					95.08.04
					RELEASED
SCALE	DRAWING NO.		PART NO.		
10 : 1	EDC3-008217-03		QR/P-XC-111(12)		
UNITS	HRS HIROSE ELECTRIC CO., LTD		CODE NO.		
mm			CL221-0009-2-12		

TO
Q2