

Jun.1.2019 Copyright 2019 HIROSE ELECTRIC CO., LTD. All Rights Reserved.  
 In case of consideration for using Automotive equipment / device which demand high reliability, kindly contact our sales window correspondents.

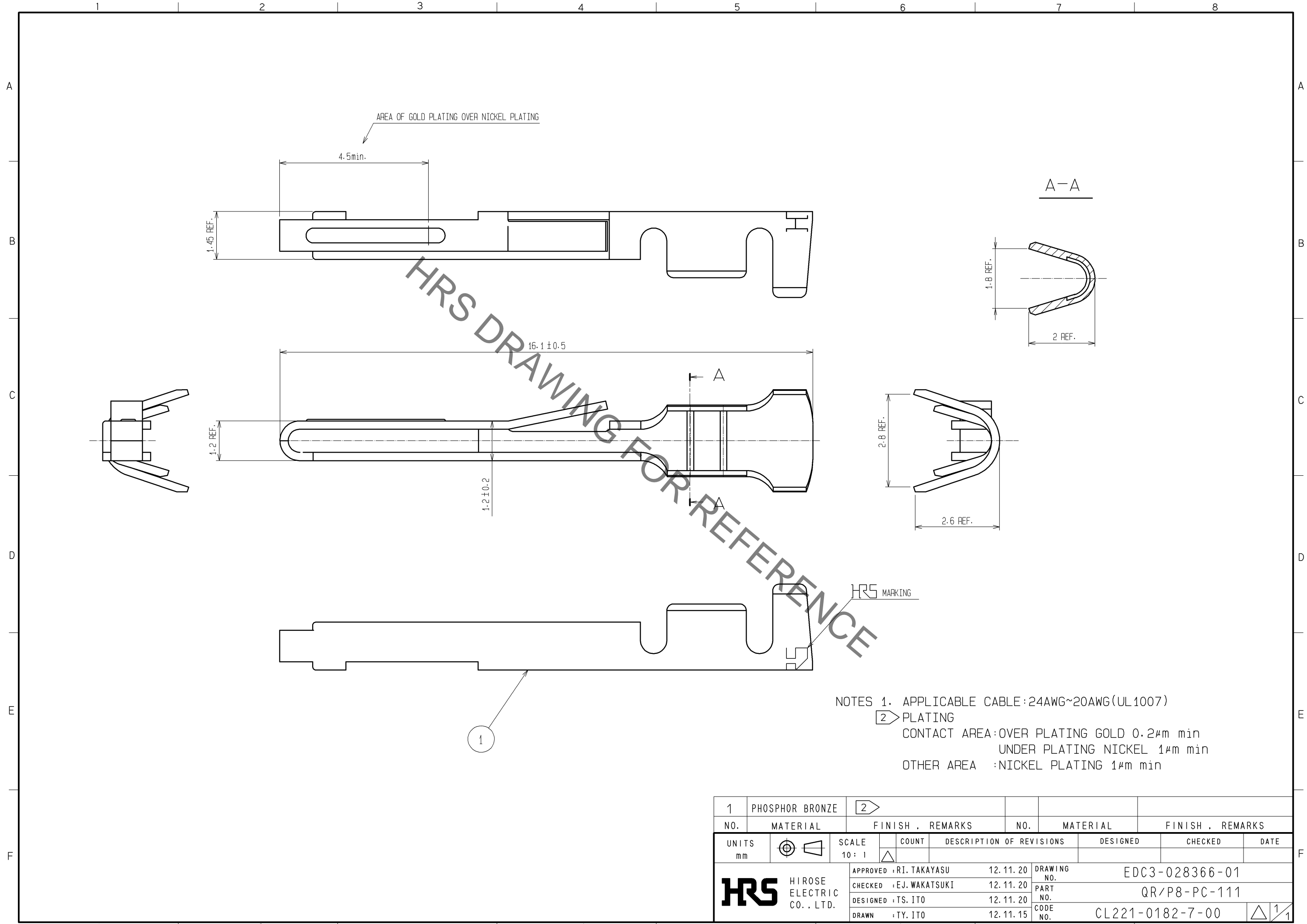

1	PHOSPHOR BRONZE	2					
NO.	MATERIAL	FINISH .	REMARKS	NO.	MATERIAL	FINISH .	REMARKS
UNITS		SCALE	COUNT	DESCRIPTION OF REVISIONS			DESIGNED
mm		10 : 1	△				CHECKED
HIROSE ELECTRIC CO., LTD.				APPROVED : RI. TAKAYASU	12.11.20	DRAWING NO. EDC3-028366-01	
				CHECKED : EJ. WAKATSUKI	12.11.20	PART NO. QR/P8-PC-111	
				DESIGNED : TS. ITO	12.11.20	CODE NO. CL221-0182-7-00	
				DRAWN : TY. ITO	12.11.15	1/1	