

CMOS Programmable Electrically Erasable Logic Device

February 1993

Features

Advanced CMOS EEPROM Technology

High Performance with Low Power Consumption

- $t_{PD} = 7.5\text{ns}, 10\text{ns}, 15\text{ns}, 25\text{ns}$ Max
- Zero Power Mode - $200\mu\text{A}$ max standby *
- $50\text{mA} + 0.5\text{mA}/\text{MHz}$ Max

EE Reprogrammability

- Superior programming
- Low-cost, "windowless" package
- Erases and programs in seconds
- Low-risk reprogrammable inventory

Development/Programmer Support

- Third-party software and programmers
- AMI PEEL Development Software with APEEL Logic Assembler

Architectural Flexibility

- 132 product term X 44 input AND array
- Up to 22 Inputs and 10 Outputs
- Variable product term distribution (8 to 16 per output) for greater logic flexibility
- Independently programmable 12-configuration I/O macrocells
- Synchronous preset, asynchronous clear
- Independent programmable output enables

Application Versatility

- Ideal for power sensitive systems
- Replaces random SSI/MSI logic
- Emulates 24-pin bipolar PAL® and GAL® devices

* PEEL22CV10(Z) only

General Description

The AMI PEEL22CV10(Z) is a CMOS Programmable Electrically Erasable Logic device that provides a high-performance, low-power, reprogrammable, and architecturally enhanced alternative to conventional programmable logic devices (PLDs). Designed in advanced CMOS EEPROM technology, the PEEL 22CV10(Z) rivals speed parameters of comparable bipolar PLDs, while providing a dramatic improvement in active power consumption. The PEEL22CV10(Z) also provides a "zero power" standby mode. The EE reprogrammability of the PEEL22CV10(Z) simplifies inventory management, reduces development and field retrofit costs, enhances testability to ensure 100% field programmability and function, and allows for low-cost, "windowless" packaging in a 24-pin, 300-mil DIP.

The PEEL22CV10(Z) offers complete function and JEDEC-file compatibility with the bipolar AmPAL 22V10 and the CMOS PALC 22V10. The PEEL22CV10(Z) also provides eight additional macrocell configurations (for a total of 12) that further expand I/O and feedback design capabilities. Applications for the PEEL22CV10(Z) include replacement of random SSI/MSI logic circuitry, emulation of 24-pin bipolar PAL® devices, and user-customized sequential and combinational functions such as counters, shift registers, state machines, address decoders, multiplexers, etc. Development support for the PEEL22CV10 and the PEEL22CV10(Z) is provided by AMI and third-party manufacturers. Programming support is provided by third-party manufacturers.

Figure 20: PEEL22CV10(Z) Pin and Block Diagram

Block Diagram

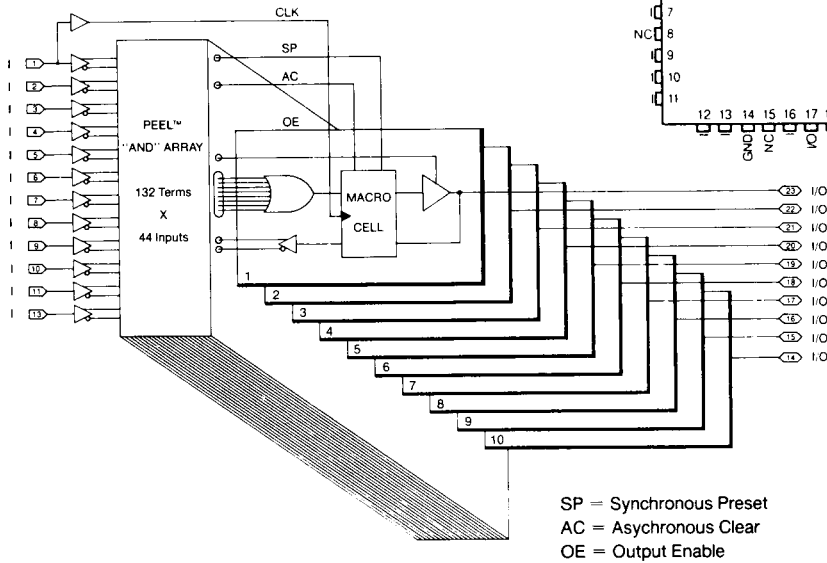

PLCC

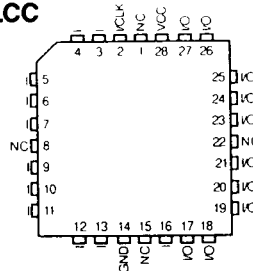

Pin Configuration

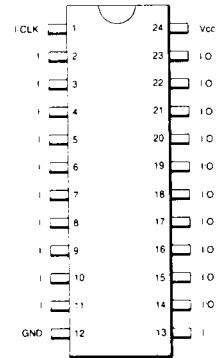

Pin Names

- I/CLK = Input Only/Clock
- I = Input Only
- I/O = Bi-Directional Input/Output
- GND = Ground
- Vcc = Power Supply (+5V)

CMOS Programmable Electrically Erasable Logic Device

February 1993

Figure 21: PEEL22CV10(Z) Logic Array Diagram

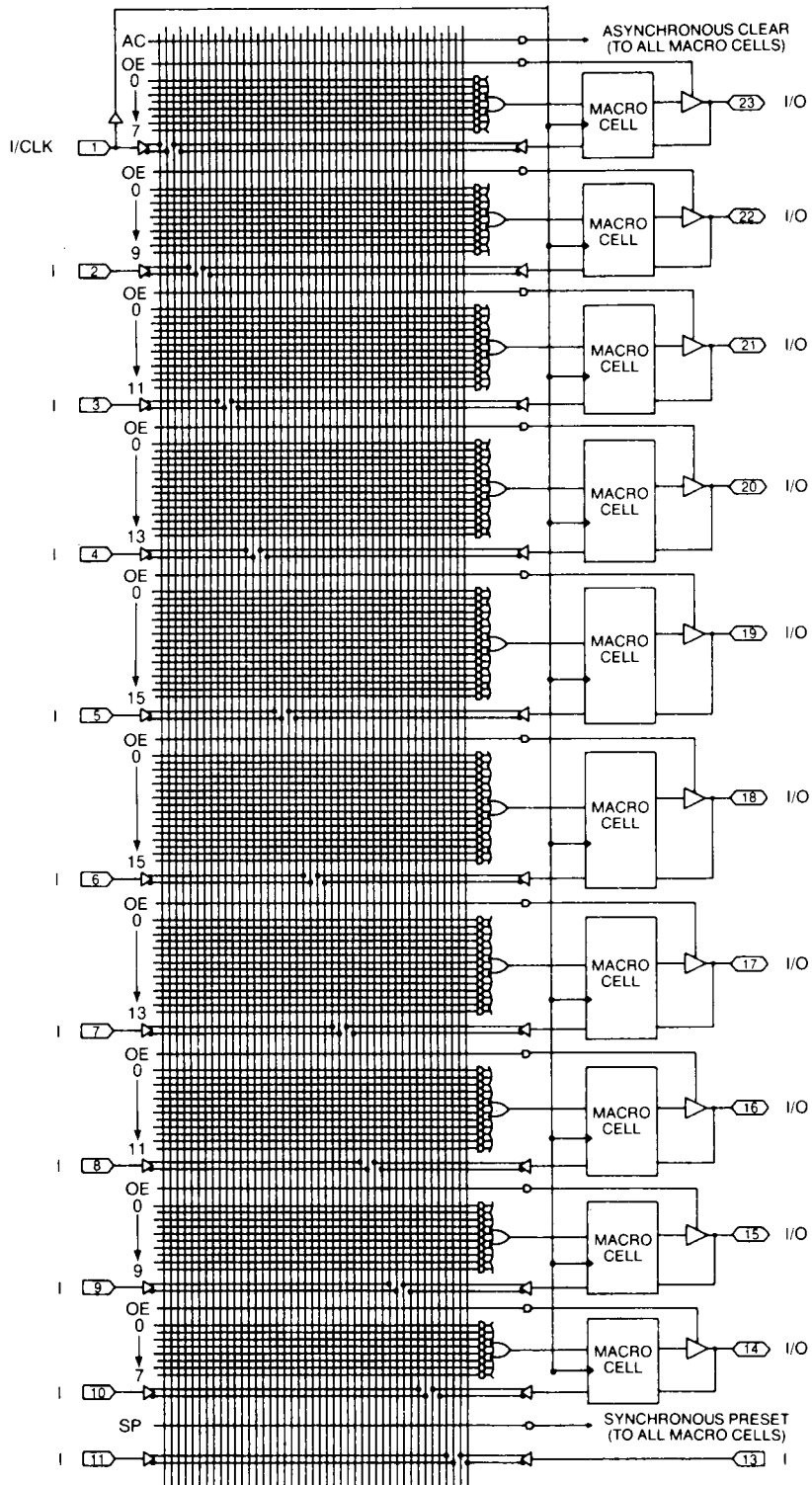

February 1993

CMOS Programmable Electrically Erasable Logic Device**Function Description**

The PEEL22CV10(Z) implements logic functions as sum-of-products expressions in a programmable-AND/fixed-OR logic array. User-defined functions are created by programming the connections of input signals into the array. User-configurable output structures in the form of I/O macrocells further increase logic flexibility.

Architectural Overview

The PEEL22CV10(Z) architecture is illustrated in the block diagram of figure 20. Twelve dedicated inputs and 10 I/Os provide up to 22 inputs and 10 outputs for creation of logic functions. At the core of the device is a programmable electrically-erasable AND array which drives a fixed-OR array. With this structure, the PEEL22CV10(Z) can implement up to 10 sum-of-products logic expressions.

Associated with each of the 10 OR functions is an I/O macrocell which can be independently programmed to one of 12 different configurations. The programmable macrocells allow each I/O to create sequential or combinational logic functions of active-high or active-low polarity, while providing three different feedback paths into the AND array.

AND/OR Logic Array

The programmable-AND array of the PEEL22CV10(Z) (shown in figure 21) is formed by input lines intersecting product terms. The input lines and product terms are used as follows:

44 Input Lines:

24 input lines carry the true and complement of the signals applied to the 12 input pins

20 additional lines carry the true and complement values of feedback or input signals from the 10 I/Os

132 product terms:

120 product terms (arranged in 2 groups of 8, 10, 12, 14, and 16) used to form logical sums

10 output enable terms (one for each I/O)

1 global synchronous preset term

1 global asynchronous clear term

At each input-line/product-term intersection is an EEPROM memory cell which determines whether or not a logical connection exists at that intersection. Each product term is essentially a 44-input AND gate. A product term which is connected to both the true and complement of an input signal will always be FALSE and thus will not affect the OR function that it drives. When all the connections on a product term are opened, a don't care state exists and that term will always be TRUE.

When programming the PEEL22CV10(Z), the device programmer first performs a bulk erase to instantly remove the previous pattern. The erase cycle opens every logical connection in the array. The device is configured to perform the user-defined function by programming selected connections in the AND array. (Note that PEEL device programmers automatically program all of the connections on unused product terms so that they will have no effect on the output function.)

Programmable I/O Macrocell

The unique 12-configuration output macrocell provides complete control over the architecture of each output. The ability to configure each output independently permits users to tailor the configuration of the PEEL22CV10(Z) to the precise requirements of their designs.

Macrocell Architecture

Each I/O macrocell, as shown in figure 22, consists of a D-type flip-flop and two signal-select multiplexers. The configuration of each macrocell is determined by the four EEPROM bits controlling these multiplexers. These bits determine output polarity, output type (registered or non-registered), and input/feedback path (bi-directional I/O, combinational feedback, or register feedback). Refer to figure 24 for details.

Equivalent circuits for the 12 macrocell configurations are illustrated in figure 23. In addition to emulating the four PAL-type output structures (configurations 3, 4, 9, and 10), the macrocell provides eight configurations that are unavailable in any PAL® device. When creating a PEEL device design, the desired macrocell configuration generally is specified explicitly in the design file. When the design is assembled or compiled, the macrocell configuration bits are defined in the last lines of the JEDEC programming file.

CMOS Programmable Electrically Erasable Logic Device

February 1993

Output Type

The signal from the OR array can be fed directly to the output pin or latched in the D-type flip-flop (registered function). The D-type flip-flop latches data on the rising edge of the clock and is controlled by the global preset and clear terms. When the synchronous preset term is satisfied, the Q output of the register will be set HIGH at the next rising edge of the clock input. Satisfying the asynchronous clear term will set Q LOW, regardless of the clock state. If both terms are satisfied simultaneously, the clear will override the preset.

Output Polarity

Each macrocell can be configured to implement active-high or active-low logic. Programmable polarity eliminates the need for external inverters.

Output Enable

The output of each I/O macrocell can be enabled or disabled under the control of its associated programmable output enable product term. When the logical conditions programmed on the output enable term are satisfied, the output signal is propagated to the I/O pin. Otherwise, the output buffer is driven into the high-impedance state.

Under the control of the output enable term, the I/O pin can function as a dedicated input, a dedicated output, or a bi-directional I/O. Opening every connection on the output

enable term will permanently enable the output buffer and yield a dedicated output. Conversely, if every connection is intact, the enable term will always be logically false and the I/O will function as a dedicated input.

Input/Feedback Select

The PEEL22CV10(Z) macrocell also provides control over the feedback path. The input/feedback signal associated with each I/O macrocell may be obtained from three different locations: from the I/O pin (bidirectional I/O), directly from the \bar{Q} output of the flip-flop (registered feedback), or directly from the OR gate (combinational feedback).

Bi-Directional I/O

The input-feedback signal is taken from the I/O pin when using the pin as a dedicated input or as a bi-directional I/O. (Note that it is possible to create a registered output function with bi-directional I/O).

Combinatorial Feedback

The signal-select multiplexer gives the macrocell the ability to feedback the output of either the OR gates, bypassing the output buffer, regardless of whether the output function is registered or combinational. This feature allows the creation of asynchronous latches, even when the output must be disabled. (Refer to configurations 5, 6, 7, and 8 in figure 23.)

Figure 22: PEEL22CV10(Z) Macrocell Diagram

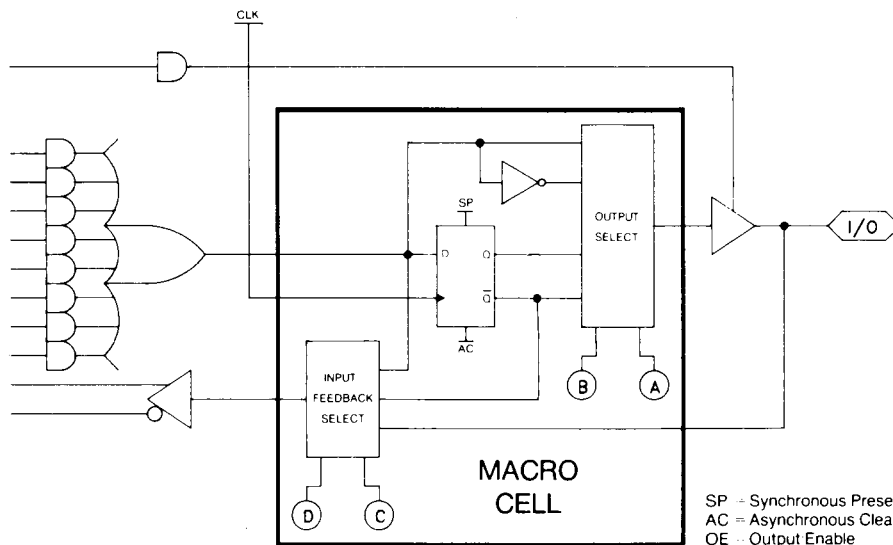
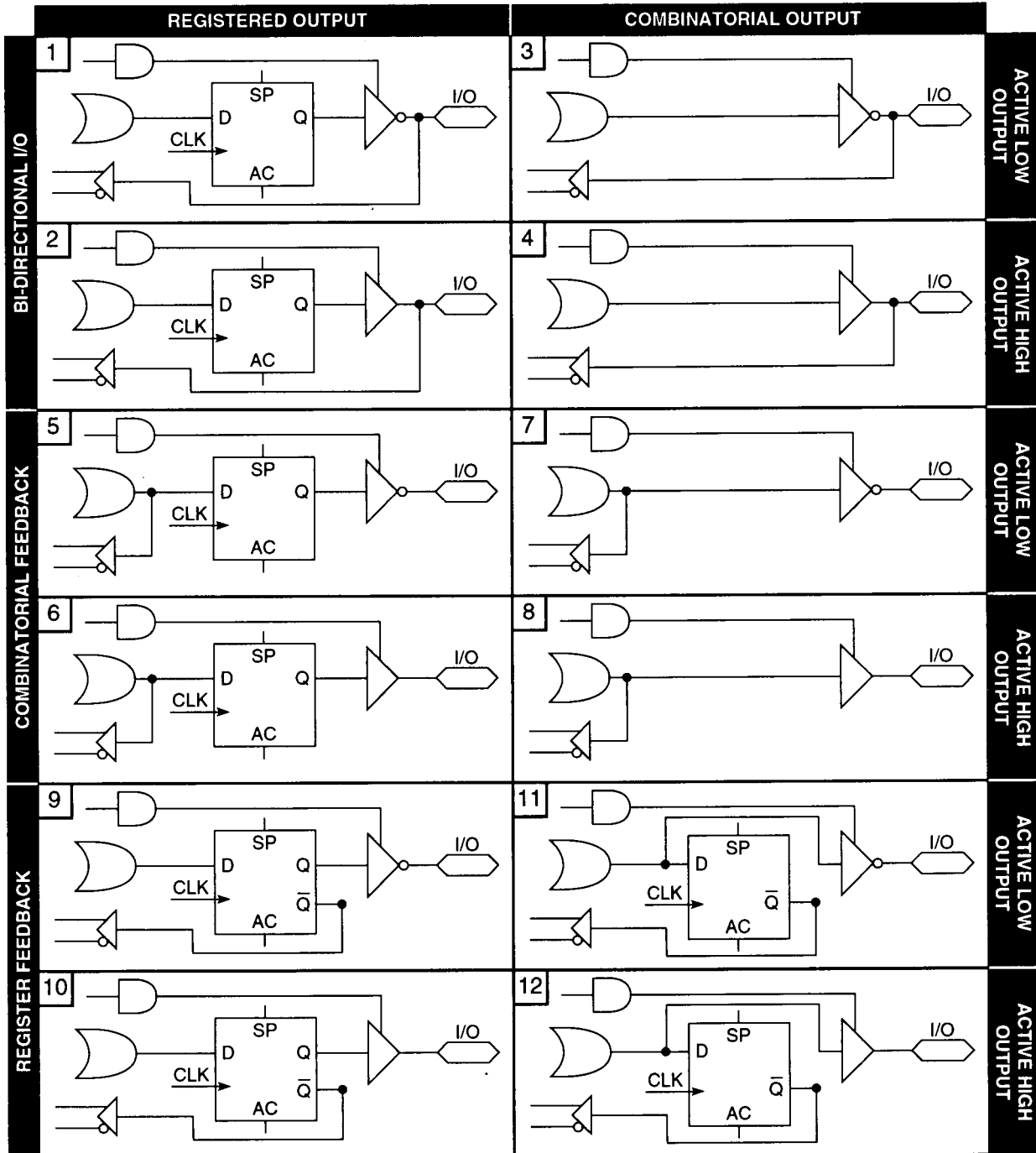

Figure 23: PEEL22CV10(Z) Macrocell Configuration Equivalent Circuits



CMOS Programmable Electrically Erasable Logic Device

February 1993

Figure 24: PEEL22CV10(Z) Macrocell Configuration Bits

Configuration					Input/Feedback Select	Output Select	
#	A	B	C	D			
1	0	0	1	0	Bi-Directional I/O	Register	Active Low
2	1	0	1	0	Bi-Directional I/O	Register	Active High
3	0	1	0	0	Bi-Directional I/O	Combinatorial	Active Low
4	1	1	0	0	Bi-Directional I/O	Combinatorial	Active High
5	0	0	1	1	Combinational Feedback	Register	Active Low
6	1	0	1	1	Combinational Feedback	Register	Active High
7	0	1	1	1	Combinational Feedback	Combinatorial	Active Low
8	1	1	1	1	Combinational Feedback	Combinatorial	Active High
9	0	0	0	0	Register Feed-back	Register	Active Low
10	1	0	0	0	Register Feed-back	Register	Active High
11	0	1	1	0	Register Feed-back	Combinatorial	Active Low
12	1	1	1	0	Register Feed-back	Combinatorial	Active High

Registered Feedback

Feedback can also be taken from the register, regardless of whether the output function is to be combinational or registered. When implementing combinational output function, registered feedback allows for the internal latching of states without giving up the use of the external output.

Design Security

The PEEL22CV10(Z) provides a special EEPROM security bit that prevents unauthorized reading or copying of designs programmed into the device. The security bit is set by the PLD programmer, either at the conclusion of the programming cycle or as a separate step, after the device has been programmed. Once the security bit is set, it is impossible to verify (read) or program the PEEL until the entire device has first been erased with the bulk-erase function.

Signature Word

The signature word feature allows a 24-bit code to be programmed into the PEEL22CV10(Z). This code then can be read back even after the security bit has been set. The signature word can be used to identify the pattern that has been programmed into the device or to record the date of programming, design revision, etc.

Zero-Power Mode

The CMOS PEEL22CV10(Z) features a user-selectable "Zero-Power" standby mode for ultra-low power consumption. When the zero-power mode is selected, transition-detection circuitry monitors the inputs, I/O (including CLK), and feedback. If the inputs do not change for a period of time equal to approximately $[t_{PD} \times 2]$, the outputs are latched in their current state and the device automatically powers-down. When the text transition is detected at the inputs, the device will "wake up" for active operation until the inputs stop switching long enough to trigger the next power-down. When powering up, an additional delay is added to the first output transition. (See AC Electrical Characteristics, note 14, for details.)

The zero-power mode is best used for combinational applications since sequential functions will be powered-up with every edge of the clock. Significant power savings can still be realized, however, when running the clock at a modest rate. Figure 27 shows the typical ICC vs. Input transition frequency for the 22CV10(Z) when the zero-power mode is programmed.

The Z-bit may be set either in the design file or when programming (depending on the programmer used). For APEEL logic assembler design files, the zero-power mode is selected using the ZERO-POWER declaration. With other logic compilers, a set fuse (to "0") command for cell location 5848 can be used.

February 1993

CMOS Programmable Electrically Erasable Logic Device

Absolute Values

Absolute Maximum Ratings⁹

SYMBOL	PARAMETER	CONDITIONS	MIN	MAX	UNIT
V _{cc}	Supply Voltage	Relative to GND	-0.5	7.0	V
V _i	Voltage applied to Input ⁴	Relative to GND ¹	-0.5	V _{cc} +0.6	V
V _o	Voltage applied to Output	Relative to GND ¹	-0.5	V _{cc} +0.6	V
I _o	Output Current	Per pin (I _{ol} , I _{oh})		+25	mA
T _{st}	Storage Temperature		-65	+150	C
T _{lt}	Lead Temperature	(soldering 10 seconds)		+300	C

Operating Ranges

SYMBOL	PARAMETER	CONDITIONS	MIN	MAX	UNIT
V _{cc}	Supply Voltage	Commercial	4.75	5.25	V
		Industrial	4.5	5.5	V
T _a	Operating Temperature	Commercial	0	+70	C
		Industrial	-40	+85	C
T _r	Clock Rise Time ⁵	Test points at 10% and 90% levels		250	ns
T _f	Clock Fall Time ⁵	Test points at 10% and 90% levels		250	ns
T _{rvcc}	V _{cc} Rise Time ⁵	Test points at 10% and 90% levels		250	ms

DC Characteristics (Over Operating Range Specifications)

SYMBOL	PARAMETER	CONDITIONS	MIN	TYP	MAX	UNIT
I _{il}	Input Leakage	V _{in} = GND to V _{cc}			±10	μA
I _{oz}	Output Leakage	I/O = High Impedance V _o = GND to V _{cc}			±10	μA
V _{il}	Input Low Voltage		-0.3		0.8	V
V _{ih}	Input High Voltage		2.0		V _{cc} +0.3	V
V _{ol}	Output Low Voltage TTL	I _{ol} = +12.0mA ¹³			0.45	V
V _{olc}	Output Low Voltage CMOS	I _{ol} = 10μA ¹³			0.1	V
V _{oh}	Output High Voltage TTL	I _{oh} = -4.0mA ¹³	2.4			V
V _{ohc}	Output High Voltage CMOS	I _{oh} = -10μA ¹³	V _{cc} -0.1			v

Capacitance

SYMBOL	PARAMETER	CONDITIONS	MIN	TYP	MAX	UNIT
C _{in} ^{3,7}	Input Capacitance	Frequency = 1MHz		4	6	pF
C _{out} ^{3,7}	Output Capacitance	Frequency = 1MHz		8	12	pF
C _{clk} ^{3,7}	Clk Pin Capacitance	Frequency = 1MHz		8	13	pF

CMOS Programmable Electrically Erasable Logic Device

February 1993

Electrical Characteristics (Over Operating Range Specifications)

PREVIEW			22CV10A-7**		22CV10A-10**		22CV10A-15		22CV10-25		22CV10Z-25	
SYMBOL	PARAMETER	UNITS	MIN	MAX	MIN	MAX	MIN	MAX	MIN	MAX	MIN	MAX
lccs	Vcc Current ¹⁰ Standby	mA		90		90		50		50		200 μ A ⁸
lcca	Vcc Current ¹⁰ Active	mA	lccs + 0.5 mA/MHz		lccs + 0.5 mA/MHz		lccs + 0.5 mA/MHz		lccs + 0.5 mA/MHz		lccs + 0.5 mA/MHz	
tPD	Input ⁴ to combina- torial output	ns		7.5		10		15		25		25
tOD	Input ⁴ to output disable ^{6,14}	ns		7.5		10		15		25		25
tOE	Input ⁴ to output enable ^{6,14}	ns		7.5		10		15		25		25
tSC	Input ⁴ set-up to clock ¹⁴	ns	3.5		7		10		15		15	
tHC	Input ⁴ hold after clock	ns	0		0		0		0		0	
tCH	Clock high time ⁵	ns	3.75		6		8		13		13	
tCL	Clock low time ⁵	ns	3.75		6		8		13		13	
tCO1	Clock to output	ns		7		8		10		15		15
tCO2	Clock to combinational out- put delay via registered feedback ³	ns		10		14		19		30		30
tCP	Minimum clock period tSC+tCO1 ¹⁴	ns	10.5		15		20		30		30	
fmax1	Max clock freq (1/tSC+tCL)	MHz	138		76.9		55.5		35.7		35.7	
fmax2	Max clock freq (1/tCP)	MHz	95.2		66.6		50		33.3		33.3	
fmax3	Max clock freq (1/tCL+tCH)	MHz	133.3		83.3		62.5		38.4		38.4	
tAW	Async clear pulse width ^{12,14}	ns	7.5		10		15		25		25	
tAP	Input ⁴ to async clear ^{12,14}	ns		10		12		18		25		25
tAR	Async reset recovery	ns		10		12		18		25		25
tRESET	Register power- on-reset ⁵	μ s		5		5		5		5		5

February 1993

CMOS Programmable Electrically Erasable Logic Device**NOTES:**

1. Minimum DC input is -0.5V; however, inputs may undershoot to -2.0V for periods less than 20ns.
2. Voltage applied to input or output must not exceed $V_c + 1.0V$.
3. These measurements are periodically sample tested.
4. "Input" refers to an Input signal.
5. Test points for Clock and V_{cc} in T_r , T_f , T_{rvcc} , t_{CH} , t_{CL} , and t_{RESET} are referenced at 10% and 90% levels.
6. See AC test point/load circuit table for t_{OE} and t_{OD} testing.
7. Typical values and capacitance are measured at $V_{cc}=5.0V$ and $T_a = 25^\circ C$.
8. Zero power mode otherwise $I_{ccs} = 65mA$.
9. Exposure to absolute maximum ratings over extended periods of time may affect device reliability. Exceeding absolute maximum ratings may cause permanent damage.
10. I/O pins are open (no load).
11. V_{in} specified is not for program/verify operation. Contact AMI for information regarding PEEL program/verify specifications.
12. Minimum width required to ensure proper asynchronous clear operation and does not imply rejection of signal less than this value.
13. Contact factory for increased IOL requirements.
14. When leaving zero power mode, the first signal transmission must add an additional delay of 10ns for these parameters.

CMOS Programmable Electrically Erasable Logic Device

February 1993

Figure 25: PEEL22CV10(Z) AC Switching Waveforms

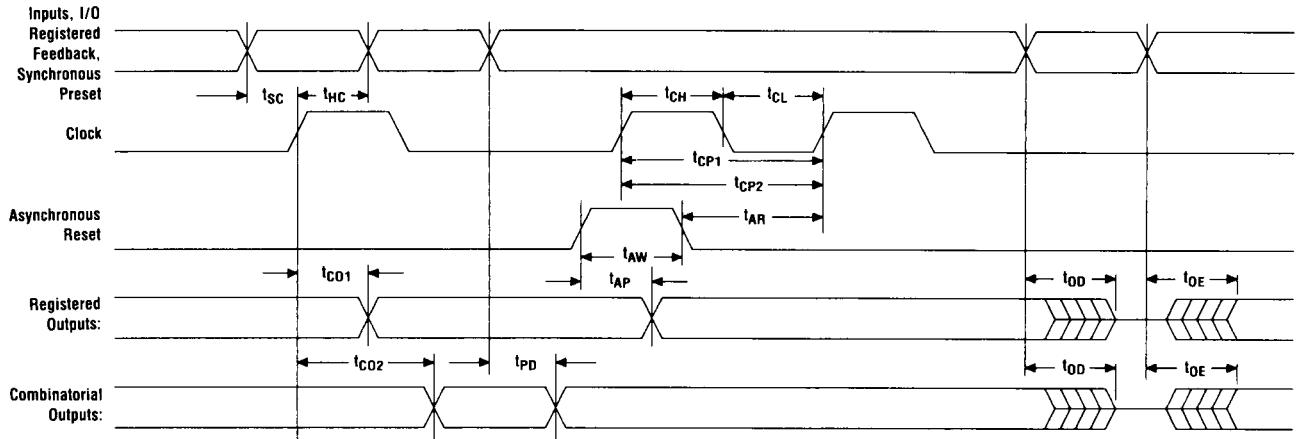
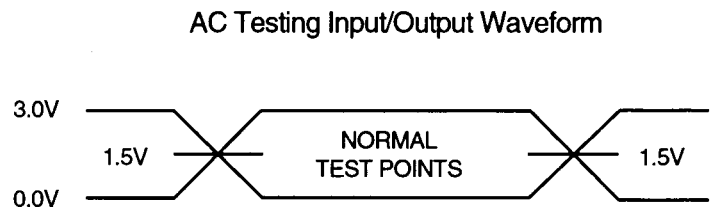
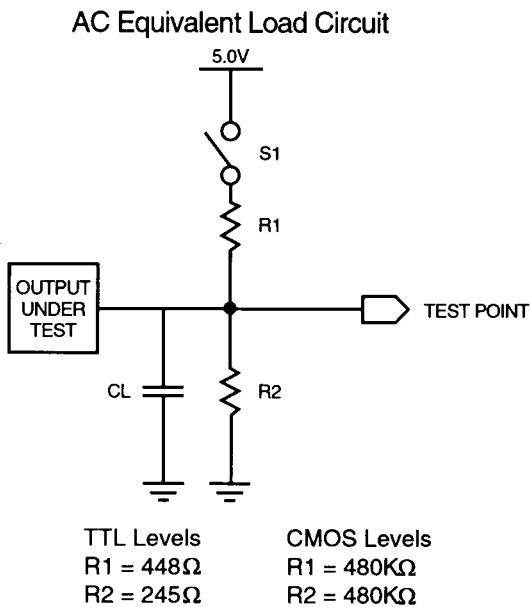

Figure 26: PEEL22CV10(Z) AC Test Loads/Waveforms



AC Test Point/Load Circuit Table

AC Test	Test Point	CL	S1
NORMAL	1.5V	50pF	closed
tOE(Z→0)	VOH	50pF	open
tOE(Z→0)	VOL	50pF	closed
tOD(1→Z)	VOH-.5V	5pF	open
tOD(0→Z)	VOL+.5V	5pF	closed

Z=High Impedance

February 1993

CMOS Programmable Electrically Erasable Logic Device

Figure 27: PEEL22CV10(Z) Typical I_{CC} vs Input Clock transition frequency (zero-power mode)

