

- Adjustable Output Voltage
- 85% Efficiency
- Small SIP Footprint
- Input Voltage Range: 4.5V to 5.5V
- Remote Sense Capability

The PT6420 series from Power Trends is a high performance +5V to +3.3V, 3Amp family of 14-Pin SIP (Single In-line Package) Integrated Switching Regulators (ISRs). Only two external capacitors are required for proper operation.

Please note that this product does not include short circuit protection.

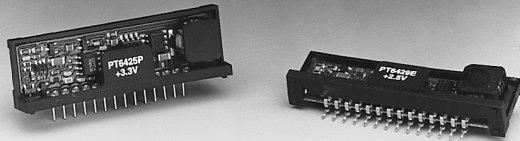

### Standard Application

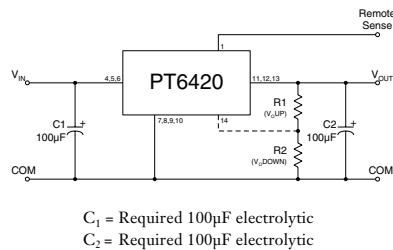

### Pin-Out Information

Pin	Function
1	Remote Sense
2	Do not connect
3	Do not connect
4	V <sub>in</sub>
5	V <sub>in</sub>
6	V <sub>in</sub>
7	GND
8	GND
9	GND
10	GND
11	V <sub>out</sub>
12	V <sub>out</sub>
13	V <sub>out</sub>
14	V <sub>out</sub> Adjust

### Ordering Information

PT6424□	= +1.5 Volts
PT6425□	= +3.3 Volts
PT6426□	= +1.8 Volts
PT6427□	= +2.1 Volts
PT6428□	= +1.2 Volts
PT6429□	= +2.5 Volts

### PT Series Suffix (PT1234X)

Case/Pin Configuration	Suffix
Vertical Through-Hole	<b>P</b>
Horizontal Through-Hole	<b>D</b>
Horizontal Surface Mount	<b>E</b>

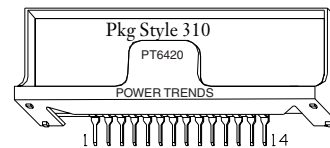

Note: Back surface of product is conducting metal.

### Specifications

Characteristics (T <sub>a</sub> = 25°C unless noted)	Symbols	Conditions	PT6420 SERIES			Units
			Min	Typ	Max	
Output Current	I <sub>o</sub>	4.5V ≤ V <sub>in</sub> ≤ 5.5V	0	—	3.0	A
Current Limit	I <sub>cl</sub>	V <sub>in</sub> = +5V	—	3.6	5.0	A
Input Voltage Range	V <sub>in</sub>	0.1A ≤ I <sub>o</sub> ≤ 3.0A	4.5	—	5.5	V
Output Voltage Tolerance	ΔV <sub>o</sub>	V <sub>in</sub> = +5V, I <sub>o</sub> = 3.0A 0°C ≤ T <sub>a</sub> ≤ +70°C	V <sub>o</sub> -0.05	3.3	V <sub>o</sub> +0.05	V
Line Regulation	Reg <sub>line</sub>	4.5V ≤ V <sub>in</sub> ≤ 5.5V, I <sub>o</sub> = 3.0A	—	±10	±25	mV
Load Regulation	Reg <sub>load</sub>	V <sub>in</sub> = +5V, 0.3 ≤ I <sub>o</sub> ≤ 3.0A	—	±10*	±25*	mV
V <sub>o</sub> Ripple/Noise	V <sub>n</sub>	V <sub>in</sub> = 5V, I <sub>o</sub> = 3.0A	—	66	165	mV <sub>pp</sub>
Transient Response with C <sub>2</sub> = 100µF	t <sub>tr</sub> V <sub>os</sub>	I <sub>o</sub> step between 1.5A and 3.0A V <sub>o</sub> over/undershoot	— —	200 200	— —	µSec mV
Efficiency	η	V <sub>in</sub> = +5V, I <sub>o</sub> = 1.5A V <sub>o</sub> = 3.3V V <sub>o</sub> = 1.8V V <sub>o</sub> = 2.1V V <sub>o</sub> = 1.2V	— — — —	85 74 77 63	— — — —	% % % %
Switching Frequency	f <sub>o</sub>	4.5V ≤ V <sub>in</sub> ≤ 5.5V 0.3A ≤ I <sub>o</sub> ≤ 3.0A	500	650	800	kHz
Absolute Maximum Operating Temperature Range	T <sub>a</sub>		0	—	+85	°C
Recommended Operating Temperature Range	T <sub>a</sub>	Free Air Convection (40-60 LFM) At Vin= 5V, Io=2.5A	0	—	+70**	°C
Thermal Resistance	θ <sub>ja</sub>	Free Air Convection (40-60 LFM)	—	25	—	°C/W
Storage Temperature	T <sub>s</sub>		-40	—	+125	°C
Mechanical Shock		Per Mil-STD-883D, Method 2002.3, 1 msec, Half Sine, mounted to a fixture	—	500	—	G's
Mechanical Vibration		Per Mil-STD-883D, Method 2007.2, 20-2000 Hz, Soldered in a PC board	—	15	—	G's
Weight	—		—	6.5	—	grams

\*When used with remote sense function.

\*\*See Thermal Derating chart.

**Note:** The PT6420 Series requires two 100µF electrolytic or tantalum capacitors for proper operation in all applications.

3 Amp 5V Input Adjustable Integrated Switching Regulator

PT6428 1.2 VDC (See Note 1)

Efficiency vs Output Current

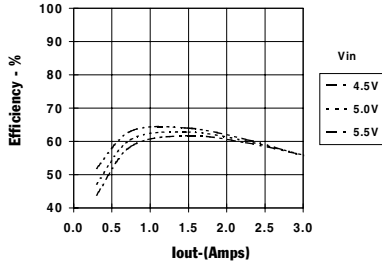

Ripple vs Output Current

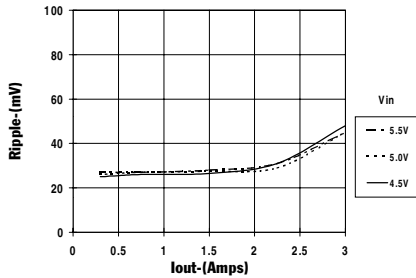

Thermal Derating (Ta) (See Note 2)

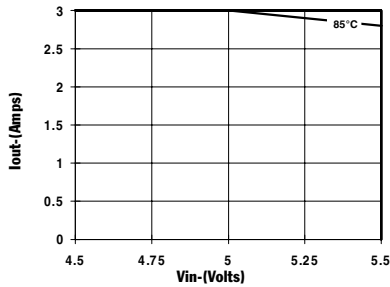

Power Dissipation vs Output Current

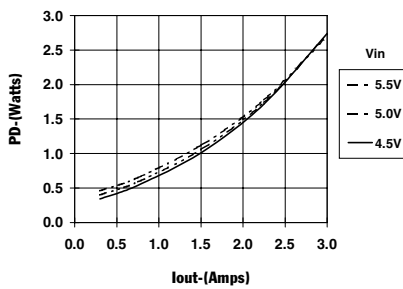

PT6427, 2.1 VDC (See Note 1)

Efficiency vs Output Current

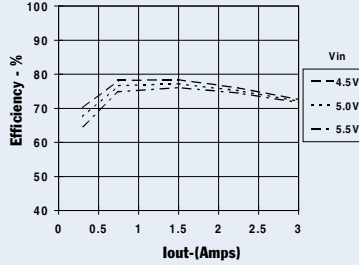

Ripple vs Output Current

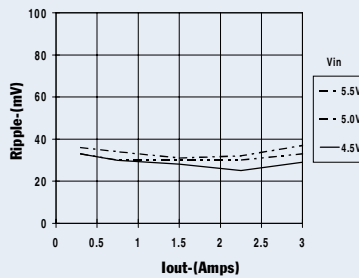

Thermal Derating (Ta) (See Note 2)

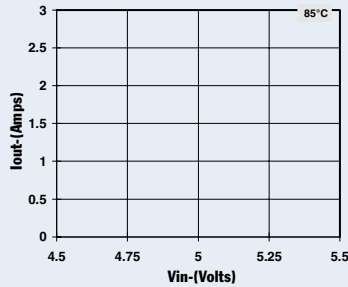

Power Dissipation vs Output Current

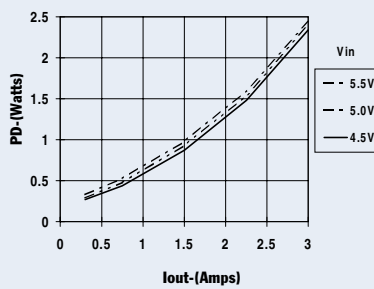

PT6425, 3.3 VDC (See Note 1)

Efficiency vs Output Current

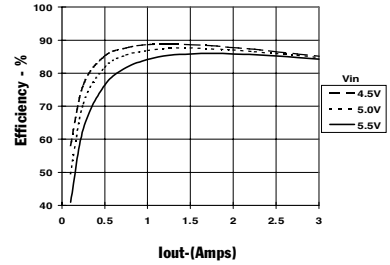

Ripple vs Output Current

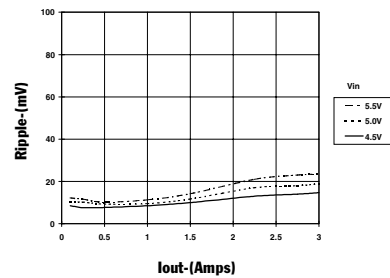

Thermal Derating (Ta) (See Note 2)

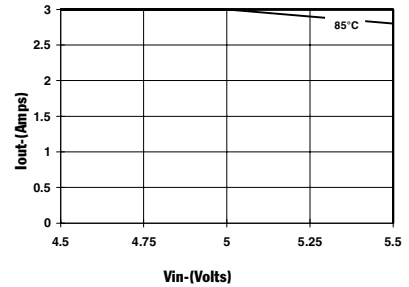

Power Dissipation vs Output Current

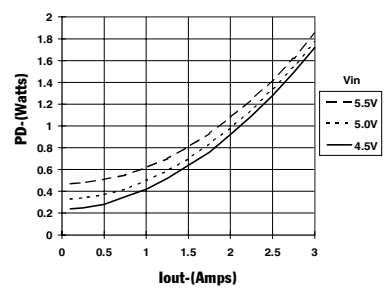

Note 1: All data listed in the above graphs except for derating data has been developed from actual products tested at 25°C. This data is considered typical data for the ISR.  
 Note 2: Thermal derating graphs are developed in free air convection cooling of 40-60 LFM. (See Thermal Application Notes.)

## PT6420 Series

### Adjusting the Output Voltage of the PT6420 Series 3AMP 5V Bus Converters

The output voltage of the Power Trends PT6420 Series ISRs may be adjusted higher or lower than the factory trimmed pre-set voltage with the addition of a single external resistor. Table 1 accordingly gives the allowable adjustment range for each model in the series as  $V_a$  (min) and  $V_a$  (max).

**Adjust Up:** (See note 1) An increase in the output voltage is obtained by adding a resistor R1, between pin 14 ( $V_o$  adjust) and pins 11-13 ( $V_{out}$ ).

**Adjust Down:** (See note 1) Add a resistor (R2), between pin 14 ( $V_o$  adjust) and pins 7-10 (GND).

Refer to Figure 1 and Table 2 for both the placement and value of the required resistor; either R1 or (R2) as appropriate.

#### Notes:

1. The direction in which each resistor adjusts the output of the PT6420 series differs from many other Power Trends products. These output voltage adjustment notes are therefore specific only to the PT6420 models.
2. Use only a single 1% resistor in either the R1 or (R2) location. Place the resistor as close to the ISR as possible.
3. Never connect capacitors from  $V_o$  adjust to either GND,  $V_{out}$ , or the Remote Sense pin. Any capacitance added to the  $V_o$  adjust pin will affect the stability of the ISR.
4. The PT6420 incorporates a Remote Sense (See Figure 1). If this feature is being used, connecting the resistor R1 between pin 14 ( $V_o$  adjust) and pin 1 (Remote Sense) can benefit load regulation.
5. An increase in the output voltage may place additional limits on the input voltage range of the part. The revised minimum input voltage will be ( $V_{out} + 1.2$ ) or 4.5V, whichever is higher. Do not exceed 5.5Vdc.

Figure 1

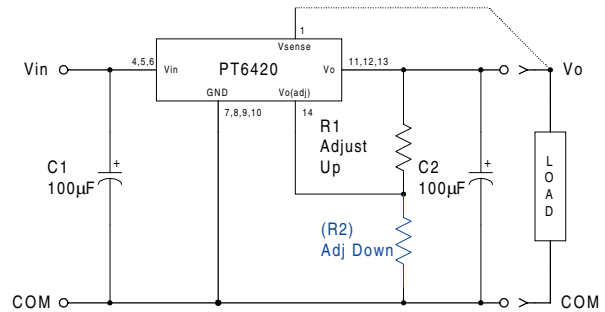

The values of R1 [adjust up], and (R2) [adjust down], can also be calculated using the following formulae.

$$R1 = \frac{12.45 V_o}{(V_a - V_o)} - 49.9 \quad \text{k}\Omega$$

$$(R2) = \frac{12.45 (2V_a - V_o)}{V_o - V_a} - 49.9 \quad \text{k}\Omega$$

Where:  $V_o$  = Original output voltage  
 $V_a$  = Adjusted output voltage

Table 1

#### PT6420 ADJUSTMENT RANGE

Series Pt #	PT6428	PT6424	PT6426	PT6427	PT6429	PT6425
$V_o$ (nom)	1.2	1.5	1.8	2.1	2.5	3.3
$V_a$ (min)	1.1	1.3	1.5	1.8	2.1	2.8
$V_a$ (max)	1.4	1.8	2.2	2.6	3.1	3.8

PT6420 Series

**Table 2**

**PT6420 ADJUSTMENT RESISTOR VALUES**

Series Pt #	PT6428	PT6424	PT6426	PT6427	PT6429	PT6425
V <sub>0</sub> (nom)	1.2	1.5	1.8	2.1	2.5	3.3
V <sub>a</sub> (req'd)						
1.1	(74.6)kΩ					
1.15	(224.0)kΩ					
1.2						
1.25	249.0kΩ					
1.3	99.5kΩ	(18.6)kΩ				
1.35	49.7kΩ	(49.7)kΩ				
1.4	24.8kΩ	(112.0)kΩ				
1.45		(299.0)kΩ				
1.5			(0.0)kΩ			
1.55		324.0kΩ	(14.8)kΩ			
1.6		137.0kΩ	(37.3)kΩ			
1.65		74.6kΩ	(74.6)kΩ			
1.7		43.5kΩ	(149.0)kΩ			
1.75		24.8kΩ	(373.0)kΩ			
1.8		12.4kΩ		(12.4)kΩ		
1.85			398.0kΩ	(29.8)kΩ		
1.9			174.0kΩ	(55.9)kΩ		
1.95			99.5kΩ	(99.5)kΩ		
2.0			62.2kΩ	(187.0)kΩ		
2.05			39.7kΩ	(448.0)kΩ		
2.1			24.8kΩ		(3.0)kΩ	
2.15			14.1kΩ	473.0kΩ	(14.1)kΩ	
2.2			6.1kΩ	212.0kΩ	(29.0)kΩ	
2.25				124.0kΩ	(49.7)kΩ	
2.3				80.8kΩ	(80.8)kΩ	
2.35				54.7kΩ	(133.0)kΩ	
2.4				37.3kΩ	(236.0)kΩ	
2.45				24.8kΩ	(548.0)kΩ	
2.5				15.5kΩ		
2.55				8.2kΩ	573.0kΩ	
2.6				2.4kΩ	261.0kΩ	
2.65					158.0kΩ	
2.7					106.0kΩ	
2.75					74.6kΩ	
2.8					53.9kΩ	(7.4)kΩ
2.85					39.0kΩ	(16.5)kΩ
2.9					27.9kΩ	(27.9)kΩ
2.95					19.3kΩ	(42.6)kΩ
3.0					12.4kΩ	(62.2)kΩ
3.1					2.0kΩ	(131.0)kΩ
3.2						(336.0)kΩ
3.3						
3.4						361.0kΩ
3.5						156.0kΩ
3.6						87.0kΩ
3.7						52.8kΩ
3.8						32.3kΩ

R1 = Black R2 = (Blue)

## IMPORTANT NOTICE

Texas Instruments Incorporated and its subsidiaries (TI) reserve the right to make corrections, modifications, enhancements, improvements, and other changes to its products and services at any time and to discontinue any product or service without notice. Customers should obtain the latest relevant information before placing orders and should verify that such information is current and complete. All products are sold subject to TI's terms and conditions of sale supplied at the time of order acknowledgment.

TI warrants performance of its hardware products to the specifications applicable at the time of sale in accordance with TI's standard warranty. Testing and other quality control techniques are used to the extent TI deems necessary to support this warranty. Except where mandated by government requirements, testing of all parameters of each product is not necessarily performed.

TI assumes no liability for applications assistance or customer product design. Customers are responsible for their products and applications using TI components. To minimize the risks associated with customer products and applications, customers should provide adequate design and operating safeguards.

TI does not warrant or represent that any license, either express or implied, is granted under any TI patent right, copyright, mask work right, or other TI intellectual property right relating to any combination, machine, or process in which TI products or services are used. Information published by TI regarding third-party products or services does not constitute a license from TI to use such products or services or a warranty or endorsement thereof. Use of such information may require a license from a third party under the patents or other intellectual property of the third party, or a license from TI under the patents or other intellectual property of TI.

Reproduction of TI information in TI data books or data sheets is permissible only if reproduction is without alteration and is accompanied by all associated warranties, conditions, limitations, and notices. Reproduction of this information with alteration is an unfair and deceptive business practice. TI is not responsible or liable for such altered documentation. Information of third parties may be subject to additional restrictions.

Resale of TI products or services with statements different from or beyond the parameters stated by TI for that product or service voids all express and any implied warranties for the associated TI product or service and is an unfair and deceptive business practice. TI is not responsible or liable for any such statements.

TI products are not authorized for use in safety-critical applications (such as life support) where a failure of the TI product would reasonably be expected to cause severe personal injury or death, unless officers of the parties have executed an agreement specifically governing such use. Buyers represent that they have all necessary expertise in the safety and regulatory ramifications of their applications, and acknowledge and agree that they are solely responsible for all legal, regulatory and safety-related requirements concerning their products and any use of TI products in such safety-critical applications, notwithstanding any applications-related information or support that may be provided by TI. Further, Buyers must fully indemnify TI and its representatives against any damages arising out of the use of TI products in such safety-critical applications.

TI products are neither designed nor intended for use in military/aerospace applications or environments unless the TI products are specifically designated by TI as military-grade or "enhanced plastic." Only products designated by TI as military-grade meet military specifications. Buyers acknowledge and agree that any such use of TI products which TI has not designated as military-grade is solely at the Buyer's risk, and that they are solely responsible for compliance with all legal and regulatory requirements in connection with such use.

TI products are neither designed nor intended for use in automotive applications or environments unless the specific TI products are designated by TI as compliant with ISO/TS 16949 requirements. Buyers acknowledge and agree that, if they use any non-designated products in automotive applications, TI will not be responsible for any failure to meet such requirements.

Following are URLs where you can obtain information on other Texas Instruments products and application solutions:

### Products

Amplifiers	<a href="http://amplifier.ti.com">amplifier.ti.com</a>
Data Converters	<a href="http://dataconverter.ti.com">dataconverter.ti.com</a>
DLP® Products	<a href="http://www.dlp.com">www.dlp.com</a>
DSP	<a href="http://dsp.ti.com">dsp.ti.com</a>
Clocks and Timers	<a href="http://www.ti.com/clocks">www.ti.com/clocks</a>
Interface	<a href="http://interface.ti.com">interface.ti.com</a>
Logic	<a href="http://logic.ti.com">logic.ti.com</a>
Power Mgmt	<a href="http://power.ti.com">power.ti.com</a>
Microcontrollers	<a href="http://microcontroller.ti.com">microcontroller.ti.com</a>
RFID	<a href="http://www.ti-rfid.com">www.ti-rfid.com</a>
RF/IF and ZigBee® Solutions	<a href="http://www.ti.com/lprf">www.ti.com/lprf</a>

### Applications

Audio	<a href="http://www.ti.com/audio">www.ti.com/audio</a>
Automotive	<a href="http://www.ti.com/automotive">www.ti.com/automotive</a>
Broadband	<a href="http://www.ti.com/broadband">www.ti.com/broadband</a>
Digital Control	<a href="http://www.ti.com/digitalcontrol">www.ti.com/digitalcontrol</a>
Medical	<a href="http://www.ti.com/medical">www.ti.com/medical</a>
Military	<a href="http://www.ti.com/military">www.ti.com/military</a>
Optical Networking	<a href="http://www.ti.com/opticalnetwork">www.ti.com/opticalnetwork</a>
Security	<a href="http://www.ti.com/security">www.ti.com/security</a>
Telephony	<a href="http://www.ti.com/telephony">www.ti.com/telephony</a>
Video & Imaging	<a href="http://www.ti.com/video">www.ti.com/video</a>
Wireless	<a href="http://www.ti.com/wireless">www.ti.com/wireless</a>

Mailing Address: Texas Instruments, Post Office Box 655303, Dallas, Texas 75265  
Copyright © 2009, Texas Instruments Incorporated