

TICPAL22V10Z-25C, TICPAL22V10Z-30I EPIC™ CMOS PROGRAMMABLE ARRAY LOGIC CIRCUITS

SRPS007C – D3323, SEPTEMBER 1989 – REVISED FEBRUARY 1992

- 24-Pin Advanced CMOS PLD
- Virtually Zero Standby Power
- Propagation Delay Time:
I, I/O to I/O in the Turbo Mode
-25C . . . 25 ns Max
-30I . . . 30 ns Max
I, I/O to I/O in the Zero-Power Mode
-25C . . . 35 ns Max
-30I . . . 40 ns Max
CLK to Q
-25C . . . 15 ns Max
-30I . . . 20 ns Max
- Variable Product Term Distribution Allows More Complex Functions to Be Implemented
- Each Output Is User-Programmable for Registered or Combinatorial Operation, Polarity, and Output Enable Control
- Extra Terms Provide Logical Synchronous Set and Asynchronous Reset Capability
- Preload Capability on All Registered Outputs Allow for Improved Device Testing
- UV Light Erasable Cell Technology Allows for:
 - Reconfigurable Logic
 - Reprogrammable Cells
 - Full Factory Testing for High Programming Yield
- Programmable Design Security Bit Prevents Copying of Logic Stored in Device
- Package Options Include Plastic Dual-In-Line and Clip Carrier [for One-Time-Programmable (OTP) Devices] and Ceramic Dual-In-Line Windowed Package

JTL AND NT PACKAGE
(TOP VIEW)

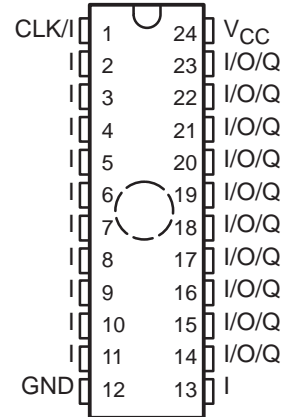

FN PACKAGE
(TOP VIEW)

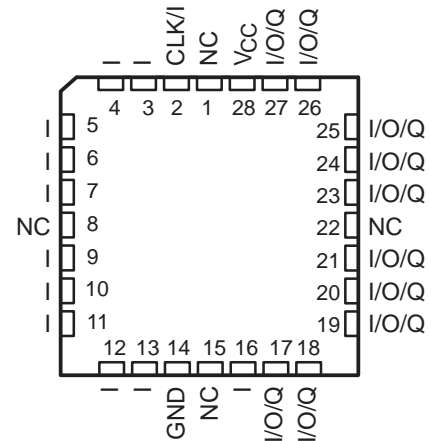

NC – No internal connection
Pin assignments in operating mode

AVAILABLE OPTIONS

TA RANGE	PACKAGE TYPE		
	CERAMIC WINDOWED DUAL-IN-LINE (JTL)	PLASTIC DUAL-IN-LINE (NT)	PLASTIC CHIP CARRIER (FN)
0°C to 75°C	TICPAL22V10Z-25CJTL	TICPAL22V10Z-25CNT	TICPAL22V10Z-25CFN
-40°C to 85°C	NA	TICPAL22V10Z-30INT	TICPAL22V10Z-30IFN

These devices are covered by U.S. Patent 4,410,987.
EPIC is a trademark of Texas Instruments Incorporated.

PRODUCTION DATA information is current as of publication date. Products conform to specifications per the terms of Texas Instruments standard warranty. Production processing does not necessarily include testing of all parameters.



POST OFFICE BOX 655303 • DALLAS, TEXAS 75265

Copyright © 1992, Texas Instruments Incorporated

TICPAL22V10Z-25C, TICPAL22V10Z-30I

EPIC™ CMOS PROGRAMMABLE ARRAY LOGIC CIRCUITS

SRPS007C – D3323, SEPTEMBER 1989 – REVISED FEBRUARY 1992

description

The CMOS PLD devices feature variable product terms, flexible outputs, and virtually zero standby power. It combines TI's EPIC™ (Enhanced Processed Implanted CMOS) process with ultraviolet-light-erasable EPROM technology. Each output has an output logic macrocell (OLM) configuration allowing for user definition of the output type. This device provides reliable, low-power substitutes for numerous high-performance TTL PLDs with gate complexities between 300 and 800 gates.

The TICPAL22V10Z has 12 dedicated inputs and 10 user-definable outputs. Individual outputs can be programmed as registered or combinational and inverting or noninverting as shown in the OLM diagram. These ten outputs are enabled through the use of individual product terms

The variable product-term distribution on this device removes rigid limitation to a maximum of eight product terms per output. This technique allocates from 8 to 16 logical product terms to each output for an average of 12 product terms per output. The variable allocation of product terms allows for far more complex functions to be implemented in this device than in previously available devices.

With features such as the programmable OLMs and the variable product-term distribution, the TICPAL22V10Z offers quick design and development of custom LSI functions. Since each of the ten output pins may be individually configured as inputs on either a temporary or permanent basis, functions requiring up to 21 inputs and a single output or down to 12 inputs and 10 outputs can be implemented with this device.

Design complexity is enhanced by the addition of synchronous set and asynchronous reset product terms. These functions are common to all registers. When the synchronous set product term is a logic 1, the output registers are loaded with a logic 1 on the next low-to-high clock transition. When the asynchronous reset product term is a logic 1, the output registers are loaded with a logic 0 independently of the clock. The output logic level after set or reset will depend on the polarity selected during programming.

Output registers of this device can be preloaded to any desired state during testing, thus allowing for full logical verification during product testing.

The TICPAL22V10Z has internal electrostatic discharge (ESD) protection circuits and has been classified with a 2000-V ESD rating tested under MIL-STD-883C, Method 3015.6. However, care should be exercised in handling these devices, as exposure to ESD may result in a degradation of the device parametric performance.

The floating-gate programmable cells allow the devices to be fully programmed and tested before assembly to assure high field programming yield and functionality. They are then erased by ultraviolet light before packaging.

The TICPAL22V10Z-25C is characterized for operation from 0°C to 75°C. The TICPAL22V10Z-30I is characterized for operation from –40°C to 85°C.

design security

The 'PAL22V10Z contains a programmable design security cell. Programming this cell will disable the read verify and programming circuitry protecting the design from being copied. The security cell is usually programmed after the design is finalized and released to production. A secured device will verify as if every location in the device is programmed. Because programming is accomplished by storing an invisible charge instead of opening a metal link, the '22V10Z cannot be copied by visual inspection. Once a secured device is fully erased, it can be reprogrammed to any desired configuration.



POST OFFICE BOX 655303 • DALLAS, TEXAS 75265

TICPAL22V10Z-25C, TICPAL22V10Z-30I EPIC™ CMOS PROGRAMMABLE ARRAY LOGIC CIRCUITS

SRPS007C – D3323, SEPTEMBER 1989 – REVISED FEBRUARY 1992

functional block diagram (positive logic)

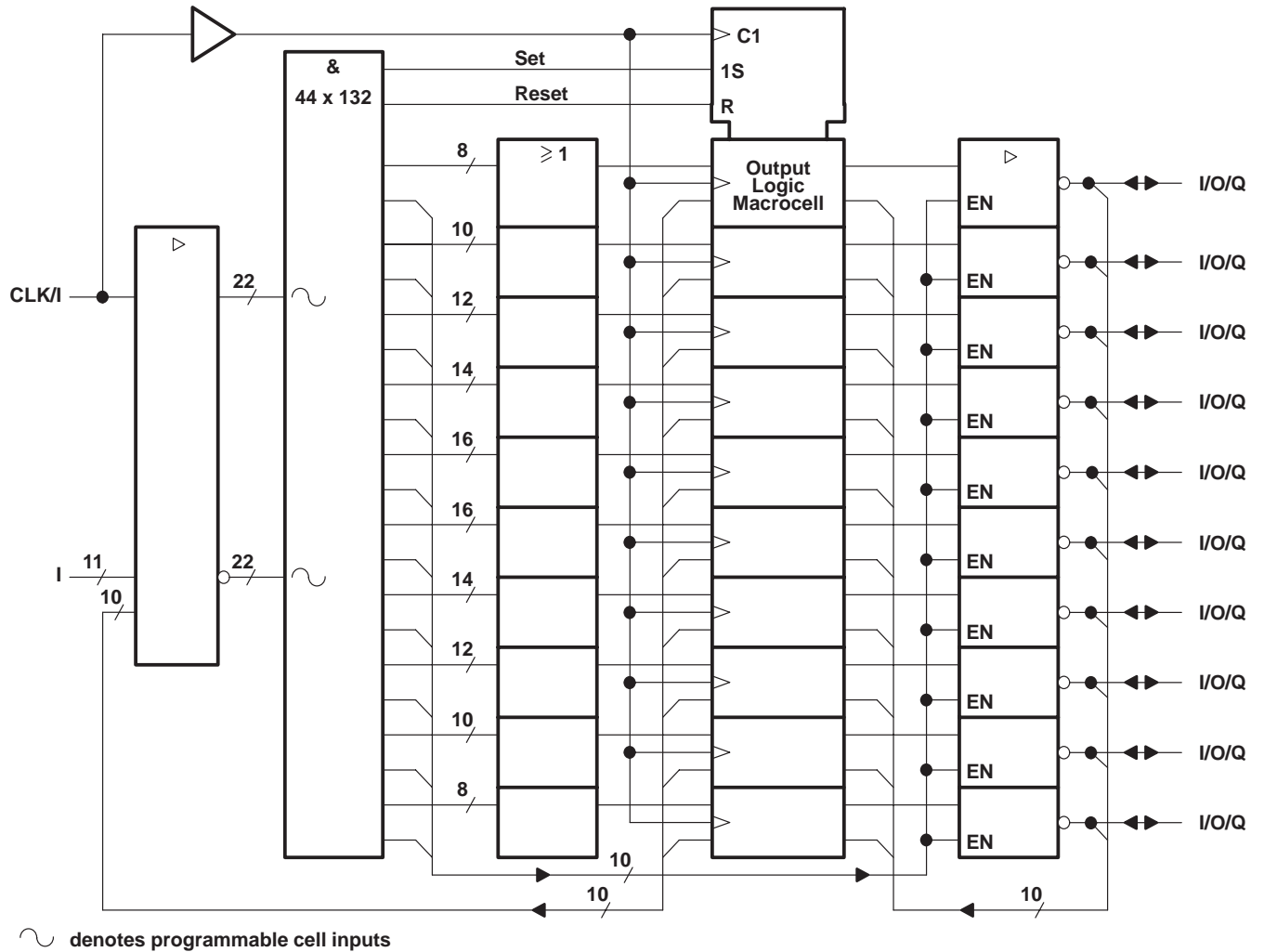

TICPAL22V10Z-25C, TICPAL22V10Z-30I
 EPIC™ CMOS PROGRAMMABLE ARRAY LOGIC CIRCUITS

SRP5007C - D3323, SEPTEMBER 1989 - REVISED FEBRUARY 1992

logic diagram (positive logic)

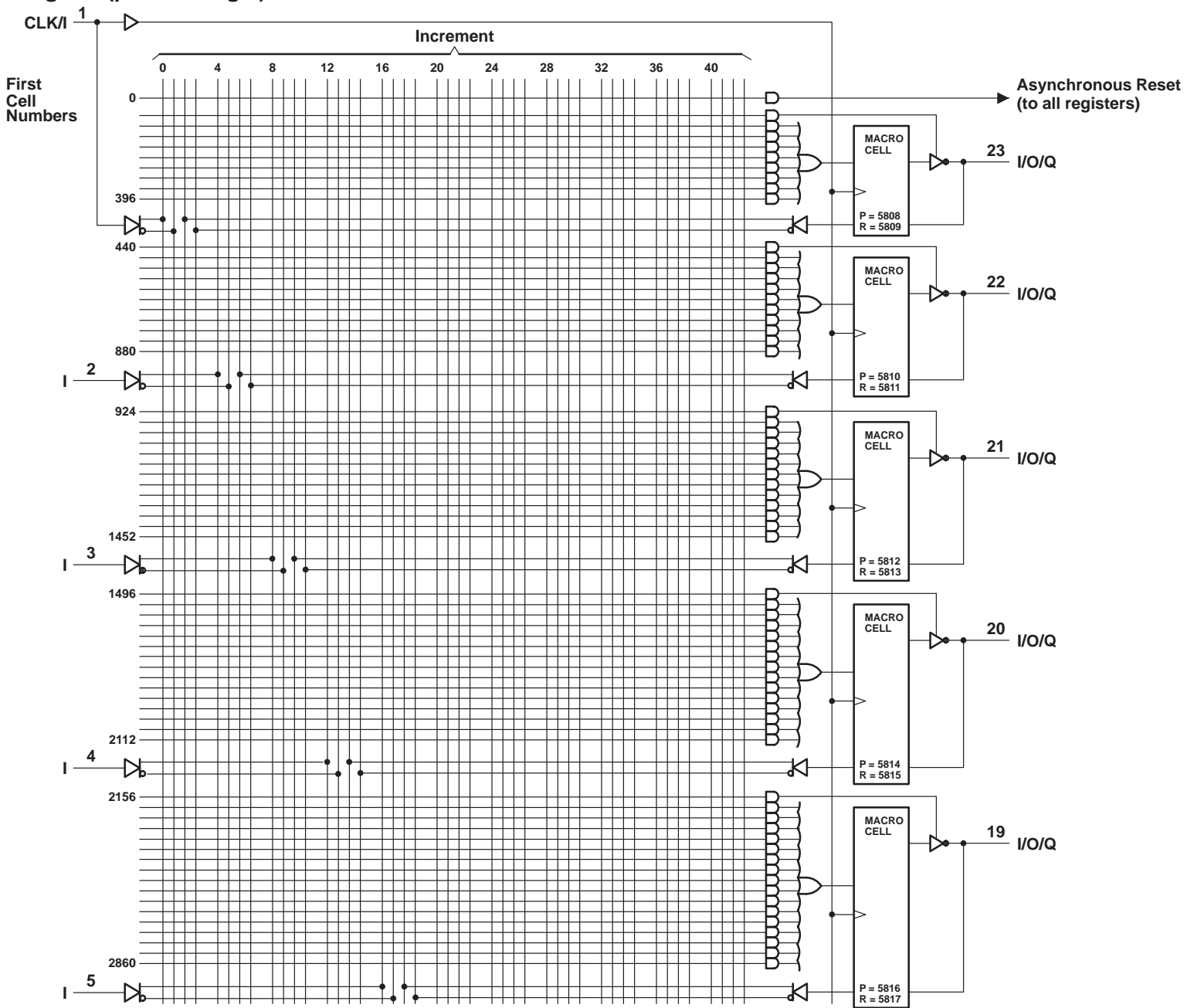

TICPAL22V10Z-25C, TICPAL22V10Z-30I EPIC™ CMOS PROGRAMMABLE ARRAY LOGIC CIRCUITS

SRP5007C - D3323, SEPTEMBER 1989 - REVISED FEBRUARY 1992

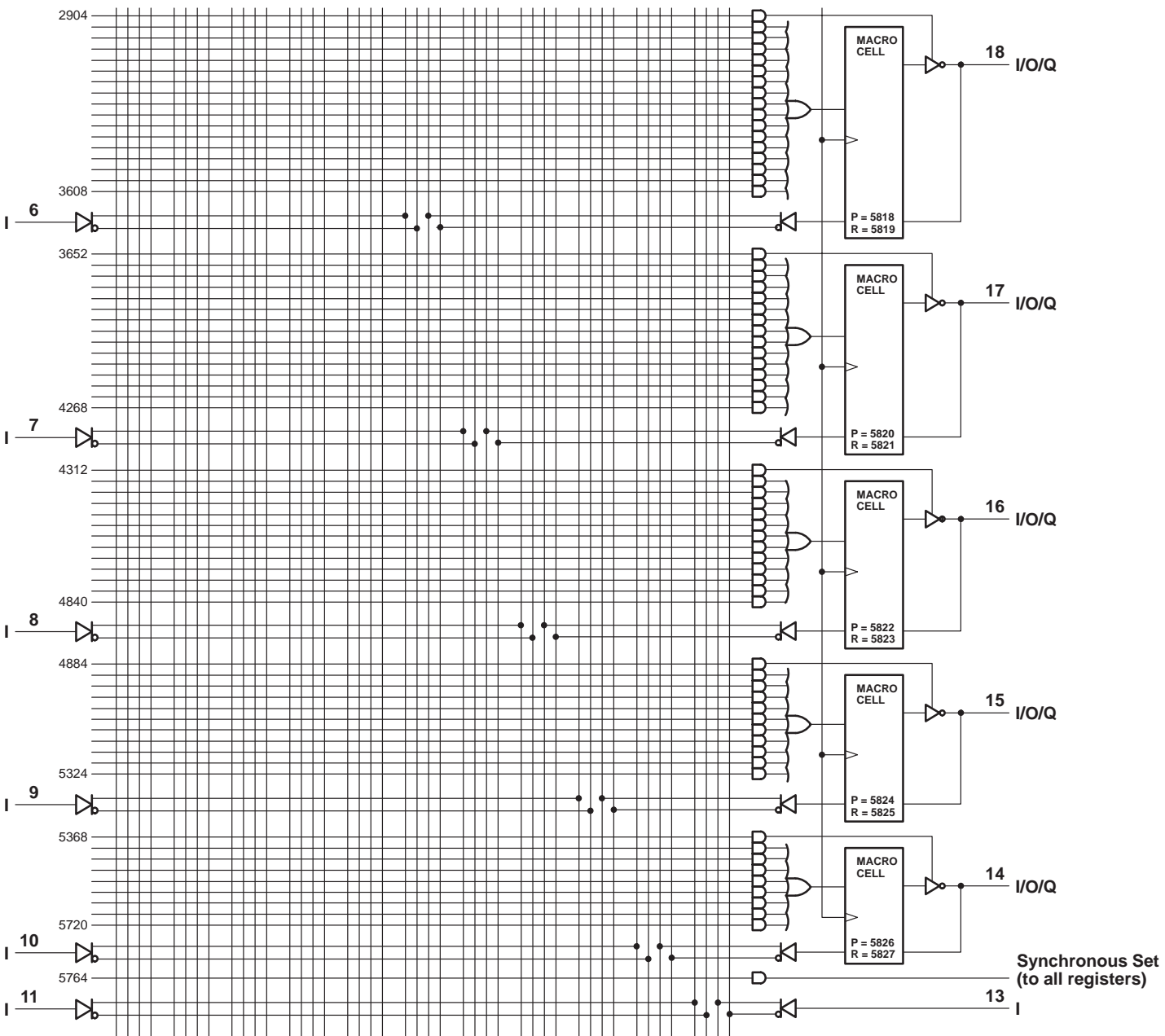

Programmable Cell Number = First Cell Number + Increment
 Inside each MACROCELL the (P) cell is the polarity cell and the (R) cell is the register cell.

TICPAL22V10Z-25C, TICPAL22V10Z-30I EPIC™ CMOS PROGRAMMABLE ARRAY LOGIC CIRCUITS

SRPS007C – D3323, SEPTEMBER 1989 – REVISED FEBRUARY 1992

output logic macrocell (OLM) description

A great amount of architectural flexibility is provided by the user-configurable macrocell output options. The macrocell consists of a D-type flip-flop and two select multiplexers. The D-type flip-flop operates like a standard TTL D-type flip-flop. The input data is latched on the low-to-high transition of the clock input. The Q and \bar{Q} outputs are made available to the output select multiplexer. The asynchronous reset and synchronous set controls are available in all flip-flops.

The select multiplexers are controlled by programmable cells. The combination of these programmable cells will determine which macrocell functions are implemented. It is this user control of the architectural structure that provides the generic flexibility of this device.

output logic macrocell diagram

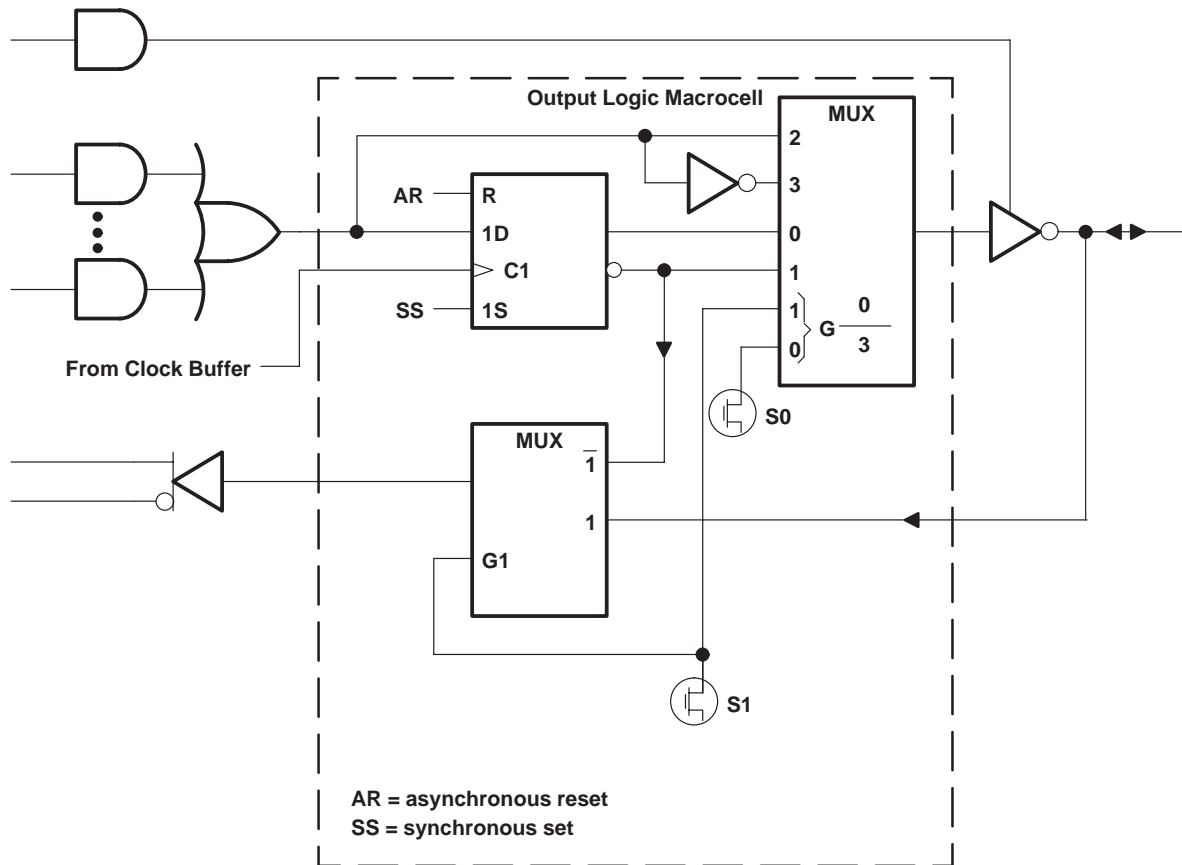

output logic macrocell options (see Figure 1)

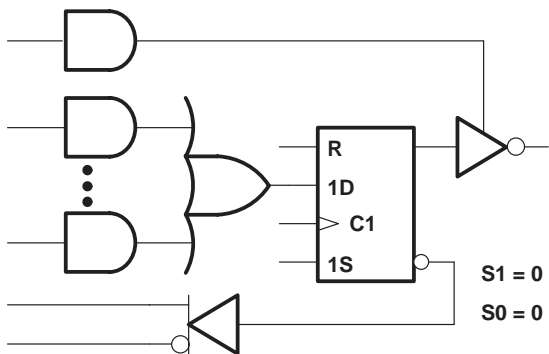

REGISTER FEEDBACK, REGISTERED, ACTIVE-LOW OUTPUT

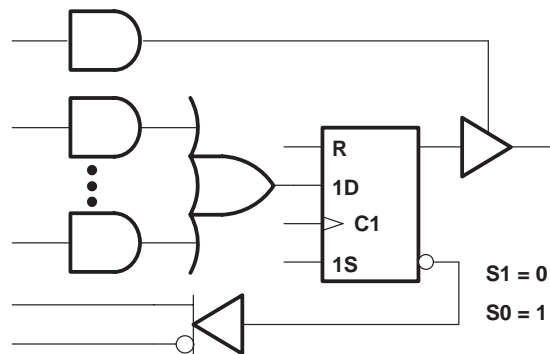

REGISTER FEEDBACK, REGISTERED, ACTIVE-HIGH OUTPUT

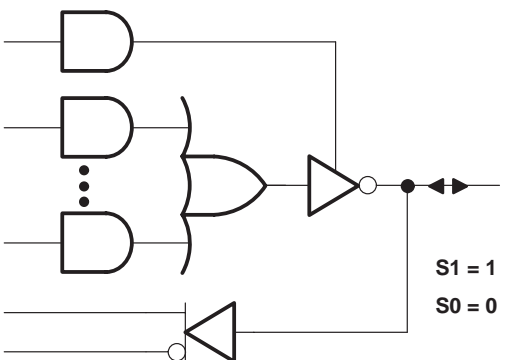

I/O FEEDBACK, COMBINATIONAL, ACTIVE-LOW OUTPUT

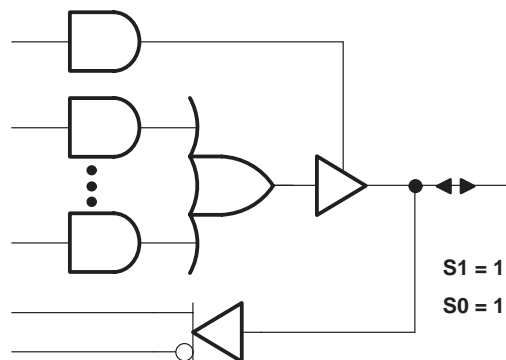

I/O FEEDBACK, COMBINATIONAL, ACTIVE-HIGH OUTPUT

MACROCELL FEEDBACK AND OUTPUT FUNCTION TABLE

CELL SELECT		FEEDBACK AND OUTPUT CONFIGURATION		
S1	S0			
0	0	Register feedback	Registered	Active low
0	1	Register feedback	Registered	Active high
1	0	I/O feedback	Combinational	Active low
1	1	I/O feedback	Combinational	Active high

0 = erased cell, 1 = programmed cell
 S1 and S0 are select-function cells as shown in the output logic macrocell diagram.

Figure 1. Resultant Macrocell Feedback and Output Logic After Programming

TICPAL22V10Z-25C

EPIC™ CMOS PROGRAMMABLE ARRAY LOGIC CIRCUITS

SRPS007C – D3323, SEPTEMBER 1989 – REVISED FEBRUARY 1992

absolute maximum ratings over operating free-air temperature range (unless otherwise noted)†

Supply voltage range, V_{CC}	–0.5 V to 7 V
Input voltage range, V_I (see Note 1)	–0.5 V to $V_{CC}+0.5$ V
Input clamp current, I_{IK} ($V_I < 0$ or $V_I > V_{CC}$)	± 20 mA
Output clamp current, I_{OK} ($V_O < 0$ or $V_O > V_{CC}$)	± 20 mA
Continuous output current, I_O ($V_O = 0$ to V_{CC})	± 40 mA
Lead temperature 1,6 mm (1/16 in) from case for 10 seconds: FN or NT package	260°C
Lead temperature 1,6 mm (1/16 in) from case for 10 seconds: JTL package	300°C
Operating free-air temperature range	0°C to 75°C
Storage temperature range	–65°C to 150°C

† Stresses beyond those listed under “absolute maximum ratings” may cause permanent damage to the device. These are stress ratings only, and functional operation of the device at these or any other conditions beyond those indicated under “recommended operating conditions” is not implied. Exposure to absolute-maximum-rated conditions for extended periods may affect device reliability.

NOTE 1: These ratings apply except for programming pins during a programming cycle or during a preload cycle.

recommended operating conditions

		MIN	NOM	MAX	UNIT
V_{CC}	Supply voltage	4.75	5	5.25	V
V_{IH}	High-level input voltage	2			V
V_{IL}	Low-level input voltage			0.8	V
I_{OH}	High-level output current	Driving TTL		–3.2	mA
		Driving CMOS		–4	
I_{OL}	Low-level output current	Driving TTL		16	mA
		Driving CMOS		4	
t_w	Pulse duration	Clock high	10		ns
		Clock low	10		
		Asynchronous reset	20		
t_{su}	Setup time, turbo mode	Input or feedback	17		ns
		Asynchronous reset inactive	20		
		Synchronous preset inactive	20		
t_{su}	Setup time, zero-power mode	Input or feedback	25		ns
		Asynchronous reset inactive	30		
		Synchronous preset inactive	30		
t_h	Hold time	0			ns
T_A	Operating free-air temperature	0		75	°C



TICPAL22V10Z-25C

EPIC™ CMOS PROGRAMMABLE ARRAY LOGIC CIRCUITS

SRPS007C – D3323, SEPTEMBER 1989 – REVISED FEBRUARY 1992

electrical characteristics over recommended operating free-air temperature range

PARAMETER		TEST CONDITION	MIN	TYP†	MAX	UNIT
V _{OH}		V _{CC} = 4.75 V, I _{OH} = -3.2 mA for TTL	4	4.8		V
		V _{CC} = 4.75 V, I _{OH} = -4 mA for CMOS	3.86	4.7		
V _{OL}		V _{CC} = 4.75 V, I _{OL} = 16 mA for TTL		0.25	0.5	V
		V _{CC} = 4.75 V, I _{OL} = 4 mA for CMOS		0.07	0.4	
I _{OZH}		V _{CC} = 5.25 V, V _O = 2.7 V		0.01	10	μA
I _{OZL}		V _{CC} = 5.25 V, V _O = 0.5 V		-0.01	-10	μA
I _{IH}		V _{CC} = 5.25 V, V _I = 5.25 V		0.01	10	μA
I _{IL}		V _{CC} = 5.25 V, V _I = 0.5 V		-0.01	-10	μA
I _{O‡}		V _{CC} = 5.25 V, V _O = 0.5 V	-30	-45	-90	mA
I _{CC§}		V _{CC} = 5.25 V, V _I = 0 or V _{CC} , Outputs open, Zero-power mode		10	100	μA
C _i	I	V _I = 2 V, f = 1 MHz		6		pF
	I/O			10		

switching characteristics over recommended ranges of supply voltage and operating free-air temperature (unless otherwise noted) (see Figure 3)

PARAMETER		FROM (INPUT)	TO (OUTPUT)	MIN	TYP†	MAX	UNIT
f _{max} ¶	Without feedback			50	66		MHz
	With feedback			31.2	55		
t _{pd}	Turbo mode	I, I/O	O, I/O		16	25	ns
	Zero-power mode				21	35	
t _{pd}	Turbo mode	Asynchronous RESET	Q		18	30	ns
	Zero-power mode				23	40	
t _{pd}		CLK↑	Q		10	15	ns
t _{en}	Turbo mode	I, I/O	I, Q, I/O		15	25	ns
	Zero-power mode				20	35	
t _{dis}	Turbo mode	I, I/O	I, Q, I/O		15	25	ns
	Zero-power mode				17	35	

† All typical values are at V_{CC} = 5 V, T_A = 25°C.

‡ Not more than one output should be shorted at a time, and the duration of the short circuit should not exceed one second. V_O is set at 0.5 V to avoid test problems caused by test equipment ground degradation.

§ Disabled outputs are tied to GND or V_{CC}.

$$¶ f_{\max}(\text{with feedback}) = \frac{1}{t_{\text{su}} + t_{\text{pd}}(\text{CLK to Q})}; f_{\max}(\text{without feedback}) = \frac{1}{t_{\text{w}}(\text{high}) + t_{\text{w}}(\text{low})}$$



TICPAL22V10Z-30I

EPIC™ CMOS PROGRAMMABLE ARRAY LOGIC CIRCUITS

SRPS007C – D3323, SEPTEMBER 1989 – REVISED FEBRUARY 1992

absolute maximum ratings over operating free-air temperature range (unless otherwise noted)†

Supply voltage range, V_{CC}	–0.5 V to 7 V
Input voltage range, V_I (see Note 1)	–0.5 V to $V_{CC}+0.5$ V
Input clamp current, I_{IK} ($V_I < 0$ or $V_I > V_{CC}$)	± 20 mA
Output clamp current, I_{OK} ($V_O < 0$ or $V_O > V_{CC}$)	± 20 mA
Continuous output current, I_O ($V_O = 0$ to V_{CC})	± 40 mA
Lead temperature 1,6 mm (1/16 in) from case for 10 seconds: FN or NT package	260°C
Operating free-air temperature range	–40°C to 85°C
Storage temperature range	–65°C to 150°C

† Stresses beyond those listed under “absolute maximum ratings” may cause permanent damage to the device. These are stress ratings only, and functional operation of the device at these or any other conditions beyond those indicated under “recommended operating conditions” is not implied. Exposure to absolute-maximum-rated conditions for extended periods may affect device reliability.

NOTE 1: These ratings apply except for programming pins during a programming cycle or during a preload cycle.

recommended operating conditions

		MIN	NOM	MAX	UNIT
V_{CC}	Supply voltage	4.5	5	5.5	V
V_{IH}	High-level input voltage	2			V
V_{IL}	Low-level input voltage			0.8	V
I_{OH}	High-level output current	Driving TTL		–3.2	mA
		Driving CMOS		–4	
I_{OL}	Low-level output current	Driving TTL		16	mA
		Driving CMOS		4	
t_w	Pulse duration	Clock high	12		ns
		Clock low	12		
		Asynchronous reset	30		
t_{su}	Setup time, turbo mode	Input or feedback	22		ns
		Asynchronous reset inactive	25		
		Synchronous preset inactive	25		
t_{su}	Setup time, zero-power mode	Input or feedback	30		ns
		Asynchronous reset inactive	35		
		Synchronous preset inactive	35		
t_h	Hold time	0			ns
T_A	Operating free-air temperature	–40		85	°C



POST OFFICE BOX 655303 • DALLAS, TEXAS 75265

TICPAL22V10Z-30I

EPIC™ CMOS PROGRAMMABLE ARRAY LOGIC CIRCUITS

SRPS007C – D3323, SEPTEMBER 1989 – REVISED FEBRUARY 1992

electrical characteristics over recommended operating free-air temperature range

PARAMETER		TEST CONDITION	MIN	TYP†	MAX	UNIT	
V _{OH}		V _{CC} = 4.5 V, I _{OH} = -3.2 mA for TTL	4	4.8		V	
		V _{CC} = 4.5 V, I _{OH} = -4 mA for CMOS	3.86	4.7			
V _{OL}		V _{CC} = 4.5 V, I _{OL} = 16 mA for TTL		0.25	0.5	V	
		V _{CC} = 4.5 V, I _{OL} = 4 mA for CMOS		0.07	0.4		
I _{OZH}		V _{CC} = 5.5 V, V _O = 2.7 V		0.01	10	μA	
I _{OZL}		V _{CC} = 5.5 V, V _O = 0.5 V		-0.01	-10	μA	
I _{IH}		V _{CC} = 5.5 V, V _I = 5.5 V		0.01	10	μA	
I _{IL}		V _{CC} = 5.5 V, V _I = 0.5 V		-0.01	-10	μA	
I _{O†}		V _{CC} = 5.5 V, V _O = 0.5 V	-30	-45	-90	mA	
I _{CC} §		V _{CC} = 5.5 V, V _I = 0 or V _{CC} , Outputs open, Zero-power mode		10	100	μA	
C _i	I	V _I = 2 V, f = 1 MHz				6	pF
	I/O					10	

switching characteristics over recommended ranges of supply voltage and operating free-air temperature (unless otherwise noted) (see Figure 3)

PARAMETER		FROM (INPUT)	TO (OUTPUT)	MIN	TYP†	MAX	UNIT
f _{max} ¶	Without feedback			41.6	66		MHz
	With feedback			23.8	55		
t _{pd}	Turbo mode	I, I/O	O, I/O		16	30	ns
	Zero-power mode				21	40	
t _{pd}	Turbo mode	Asynchronous RESET	Q		18	35	ns
	Zero-power mode				23	45	
t _{pd}		CLK↑	Q		10	20	ns
t _{en}	Turbo mode	I, I/O	I, Q, I/O		15	30	ns
	Zero-power mode				20	40	
t _{dis}	Turbo mode	I, I/O	I, Q, I/O		15	30	ns
	Zero-power mode				17	40	

† All typical values are at V_{CC} = 5 V, T_A = 25°C.

‡ Not more than one output should be shorted at a time, and the duration of the short circuit should not exceed one second. V_O is set at 0.5 V to avoid test problems caused by test equipment ground degradation.

§ Disabled outputs are tied to GND or V_{CC}.

$$¶ f_{\max}(\text{with feedback}) = \frac{1}{t_{\text{su}} + t_{\text{pd}}(\text{CLK to Q})}; f_{\max}(\text{without feedback}) = \frac{1}{t_{\text{w}}(\text{high}) + t_{\text{w}}(\text{low})}$$



TICPAL22V10Z-25C, TICPAL22V10Z-30I

EPIC™ CMOS PROGRAMMABLE ARRAY LOGIC CIRCUITS

SRPS007C – D3323, SEPTEMBER 1989 – REVISED FEBRUARY 1992

preload procedure for registered outputs (see Notes 2 and 3)

The output registers can be preloaded to any desired state during device testing. This permits any state to be tested without having to setup through the entire state-machine sequence. Each register is preloaded individually by following the steps given below. The output level depends on the polarity selected during programming.

- Step 1. With V_{CC} at 5 V and pin 1 at V_{IL} , raise pin 8 to V_{IHH} .
- Step 2. Apply either V_{IL} or V_{IH} to the output corresponding to the register to be preloaded.
- Step 3. Pulse pin 1, clocking in preload data.
- Step 4. Remove output voltage, then lower pin 8 to V_{IL} . Preload can be verified by observing the voltage level at the output pin.

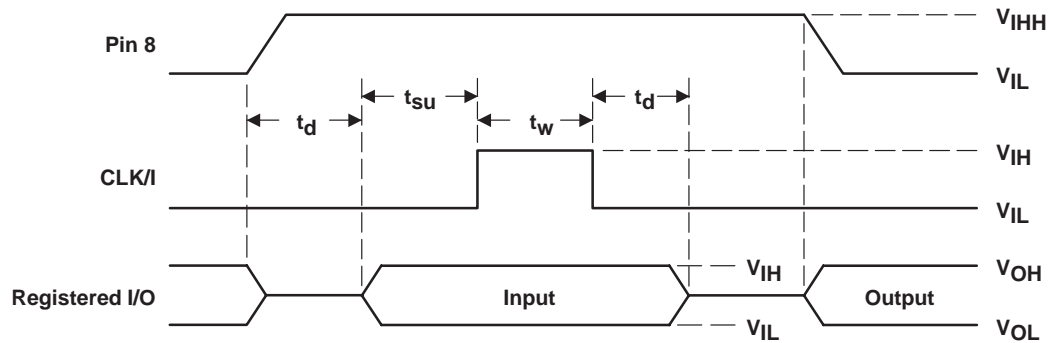

Figure 2. Preload Waveforms

- NOTES: 2. Pin numbers shown are for the JTL and NT packages only. If chip-carrier socket adapter is not used, pin numbers must be changed accordingly.
3. $t_d = t_{su} = t_w = 100$ ns to 1000 ns. $V_{IHH} = 10.25$ V to 10.75 V.

programming information

Texas Instruments programmable logic devices can be programmed using widely available software and inexpensive device programmers.

Complete programming specifications, algorithms, and the latest information on hardware, software, and firmware are available upon request. Information on programmers capable of programming Texas Instruments programmable logic is also available, upon request, from the nearest TI field sales office, local authorized TI distributor, or by calling Texas Instruments at (214) 997-5666.

PARAMETER MEASUREMENT INFORMATION

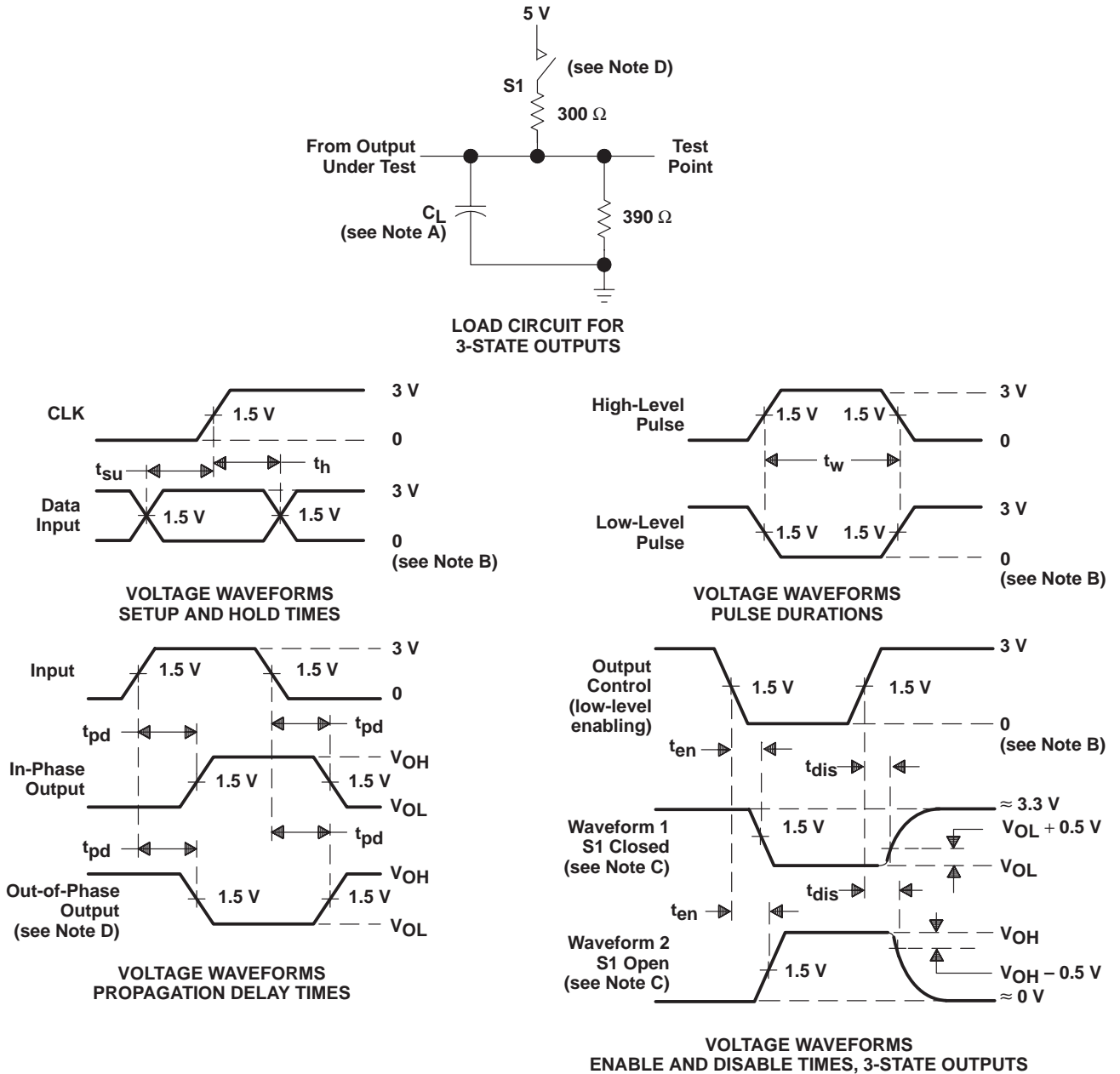

- NOTES: A. C_L includes probe and jig capacitance and is 50 pF for t_{pd} and t_{en} , 5 pF for t_{dis} .
 B. All input pulses have the following characteristics: $PRR \leq 1$ MHz, $Z_0 = 50 \Omega$, $t_r = t_f = 2$ ns, duty cycle = 50%.
 C. Waveform 1 is for an output with internal conditions such that the output is low except when disabled by the output control. Waveform 2 is for an output with internal conditions such that the output is high except when disabled by the output control.
 D. When measuring propagation delay times of 3-state outputs, switch S1 is closed.
 E. Equivalent loads may be used for testing.

Figure 3. Load Circuit and Voltage Waveforms

TICPAL22V10Z-25C, TICPAL22V10Z-30I

EPIC™ CMOS PROGRAMMABLE ARRAY LOGIC CIRCUITS

SRPS007C – D3323, SEPTEMBER 1989 – REVISED FEBRUARY 1992

special design features

True CMOS Outputs: Each TICPAL22V10Z output is designed with a P-channel pull-up transistor and an N-channel pull-down transistor, a true CMOS output with rail-to-rail output switching. This provides direct interface to CMOS logic, memory, or ASIC devices without the need for a pull-up resistor. The CMOS output has 16-mA drive capability, which makes the TICPAL22V10Z an ideal substitute for bipolar PLDs. The electrical characteristics of this device show the output under both CMOS and TTL conditions.

Simultaneous Switching: High-performance CMOS devices often have output glitches on nonswitched outputs when a large number of outputs are switched simultaneously. This glitch is commonly referred to as "ground bounce" and is most noticeable on outputs held at V_{OL} (low-level output voltage). Ground bounce is caused by the voltage drop across the inductance in the package lead when current is switched ($dv \propto L \times di/dt$).

One solution is to restrict the number of outputs that can switch simultaneously. Another solution is to change the device pinout such that the ground is located on a low-inductance package pin. TI opted for a third option in order to maintain pinout compatibility and eliminate functional constraints. This option controls the output transistor turn-on characteristics and puts a limit on the instantaneous current available to the load, much like the I_{OS} resistor in a TTL circuit.

Wake-Up Features: The TICPAL22V10Z employs input signal transition detection techniques to power up the device from the standby-power mode. The transition detector monitors all inputs, I/Os, and feedback paths. Whenever a transition is sensed, the detector activates the power-up mode. The device will remain in the power-up mode until the detector senses that the inputs and outputs have been static for about 40 ns; thereafter, the device returns to the standby mode.

Turbo Mode or Zero-Power Mode: When the turbo cell is programmed, the device will be set to the power-up mode. Therefore, the delay associated with its transition detection and power up will be eliminated. This is how the faster propagation delays and shorter setup times are obtained in the turbo mode. The turbo mode and the associated speed increase can be effectively simulated with the turbo cell erased, if a series of adjacent input, I/O, or feedback edges occur with an interval of about 25 ns or less between these adjacent edges. Under these conditions, the TICPAL22V10Z will never have the opportunity to power down due to the frequency of the adjacent edges.

Power Up: The TICPAL22V10Z device configuration bits (power mode, and macrocell configuration) are read at the first input transition after a monotonic power up. When completed, the TICPAL22V10Z is in its designed configuration. The use of an initializing device reset is necessary in applications where registered feedback is used to ensure the TICPAL22V10Z is in a known state at the beginning of system operation.

Power Dissipation: Power dissipation of the TICPAL22V10Z is defined by three contributing factors, and the total power dissipation is the sum of all three.

Standby Power: The product of V_{CC} and the standby I_{CC} . The standby current is the reverse current through the diodes that are reversed biased. This current is very small, and for circuits that remain in static condition for a long time, this low amount of current can become a major performance advantage.

Dynamic Power: The product of V_{CC} and the dynamic current. This dynamic current flows through the device only when the transistors are switching from one logic level to the other. The total dynamic current for the TICPAL22V10Z is dependent upon the users' configuration of the device and the operating frequency. Output loading can be a source of additional power dissipation.

Interface Power: The product of I_{CC} (interface) and V_{CC} . The total interface power is dependent on the number of inputs at the TTL V_{OH} level. The interface power can be eliminated by the addition of a pull-up resistor.



POST OFFICE BOX 655303 • DALLAS, TEXAS 75265

Even though power dissipation is a function of the user's device configuration and the operating frequency, the TICPAL22V10Z is a lower powered solution than either the quarter-powered or half-powered bipolar devices. The virtually zero standby power feature makes the TICPAL22V10Z the device of choice for low-duty-cycle applications.

programming and erasability

Programming of the TICPAL22V10Z is achieved through floating-gate avalanche injection techniques. The charge trapped on the floating gate remains after power has been removed, allowing for the nonvolatility of the programmed data. The charge can be removed by exposure to light with wavelengths of less than 400 nm (4000 Å). The recommended erasure wavelength is 253.7 nm (2537 Å), with erasure time of 60 to 90 minutes, using a light source with a power rating of 12000 $\mu\text{W}/\text{cm}^2$ placed within 2.5 cm (one inch) of the device.

The TICPAL22V10Z is designed for programming endurance of 1000 write/erase cycles with a data retention of ten years. To guarantee maximum data retention, the window on the device should be covered by an opaque label. The fluorescent light in a room can erase a unit in three years or, in the case of a direct sunlight, erasure can be complete in one week.

TYPICAL CHARACTERISTICS

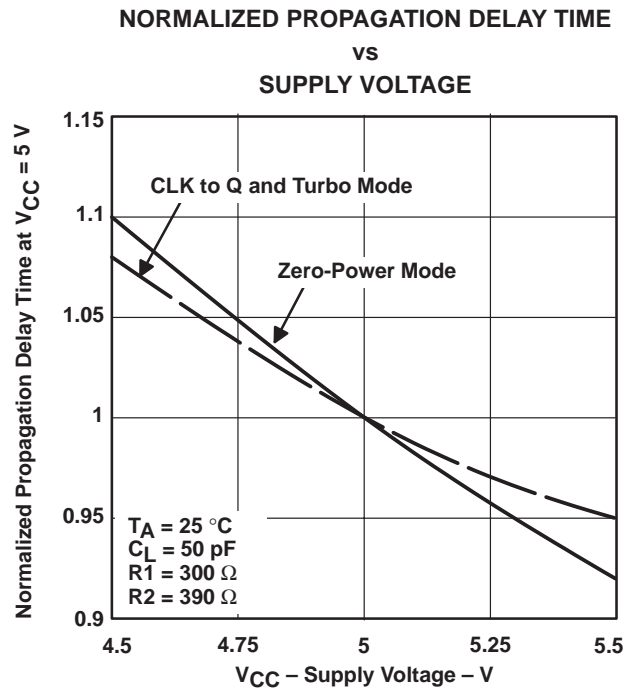
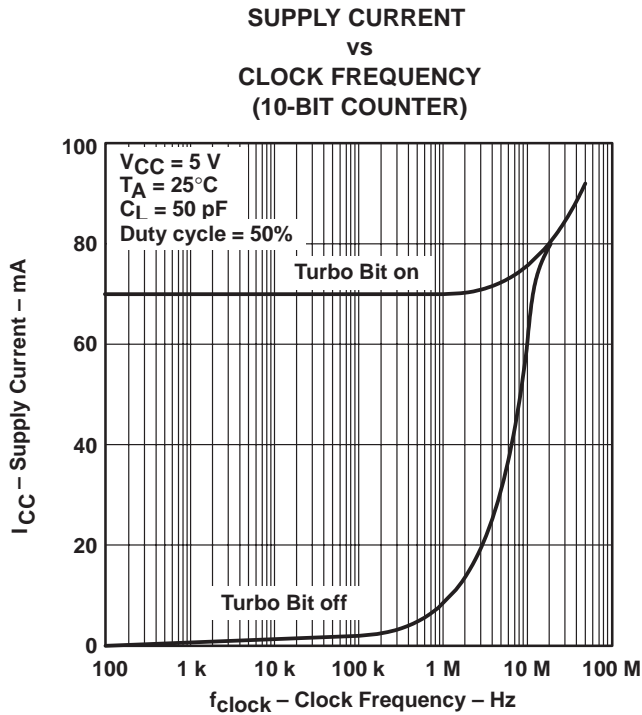
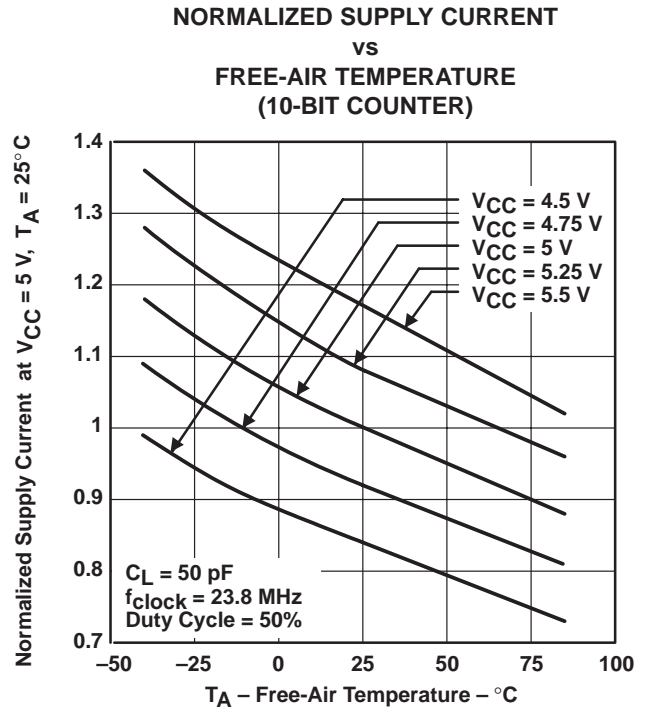
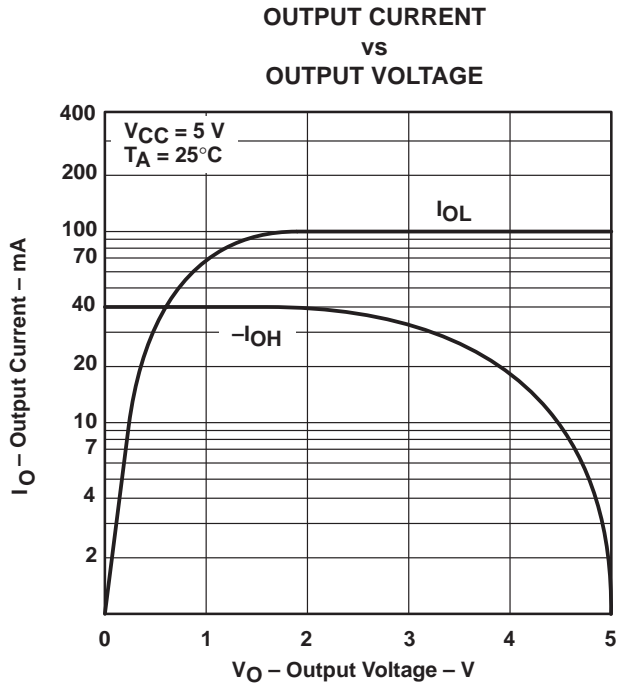

TYPICAL CHARACTERISTICS

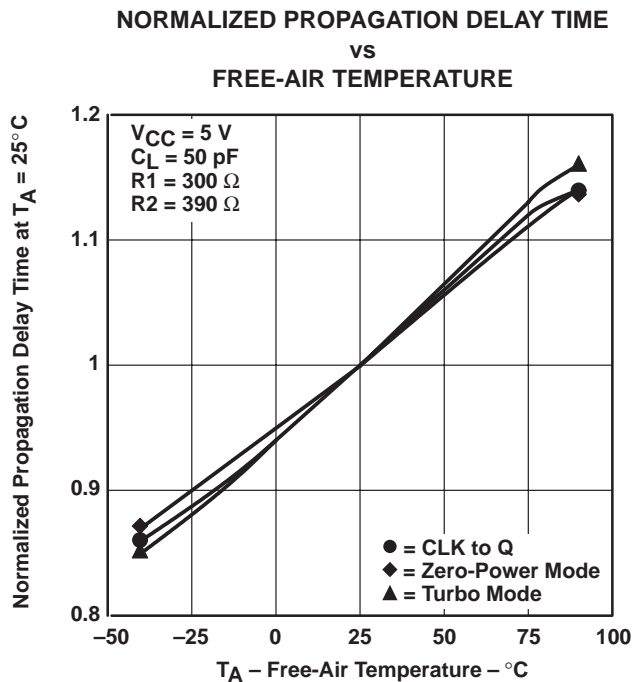

Figure 8

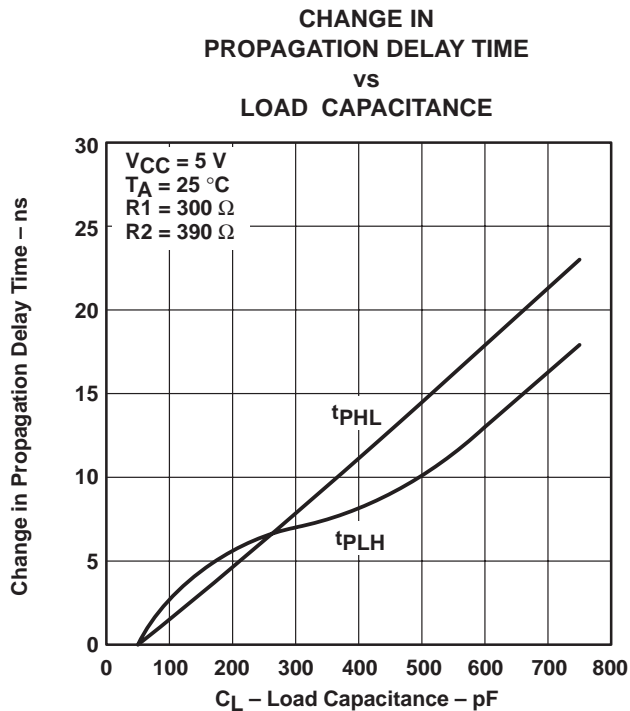

Figure 9

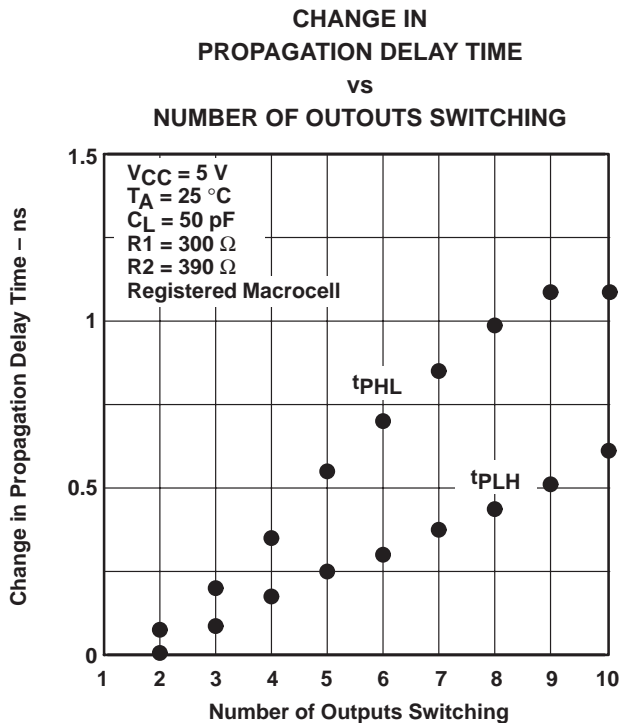

Figure 10

TI Worldwide Sales Offices

ALABAMA: Huntsville: 4960 Corporate Drive, Suite 150, Huntsville, AL 35805, (205) 837-7530.

ARIZONA: Phoenix: 8825 N. 23rd Avenue, Suite 100, Phoenix, AZ 85021, (602) 995-1007.

CALIFORNIA: Irvine: 1920 Main Street, Suite 900, Irvine, CA 92714, (714) 660-1200;

San Diego: 5625 Ruffin Road, Suite 100,

San Diego, CA 92123, (619) 278-9600;

Santa Clara: 5353 Betsy Ross Drive,

Santa Clara, CA 95054, (408) 980-9000;

Woodland Hills: 21550 Oxnard Street, Suite 700,

Woodland Hills, CA 91367, (818) 704-8100.

COLORADO: Aurora: 1400 S. Potomac Street, Suite 101, Aurora, CO 80012, (303) 368-8000.

CONNECTICUT: Wallingford: 9 Barnes Industrial Park So., Wallingford, CT 06492, (203) 269-0074.

FLORIDA: Altamonte Springs: 370 S. North Lake Boulevard, Suite 1008, Altamonte Springs, FL 32701, (407) 260-2116;

Fort Lauderdale: 2950 N.W. 62nd Street,

Suite 100, Fort Lauderdale, FL 33309,

(305) 973-8502; **Tampa:** 4803 George Road, Suite 390,

Tampa, FL 33634-6234, (813) 885-7588.

GEORGIA: Norcross: 5515 Spalding Drive, Norcross, GA 30092-2560, (404) 662-7967.

ILLINOIS: Arlington Heights: 515 West Algonquin, Arlington Heights, IL 60005, (708) 640-6925.

INDIANA: Carmel: 550 Congressional Drive, Suite 100, Carmel, IN 46032, (317) 573-6400;

Fort Wayne: 103 Airport North Office Park,

Fort Wayne, IN 46825, (219) 489-4697.

KANSAS: Overland Park: 7300 Colledge Boulevard, Lighton Plaza, Suite 150, Overland Park, KS 66210, (913) 451-4511.

MARYLAND: Columbia: 8815 Centre Park Drive, Suite 100, Columbia, MD 21045, (410) 964-2003.

MASSACHUSETTS: Waltham: Bay Colony Corporate Center 950 Winter Street, Suite 2800, Waltham, MA 02154, (617) 895-9100.

MICHIGAN: Farmington Hills: 33737 W. 12 Mile Road, Farmington Hills, MI 48018, (313) 553-1581.

MINNESOTA: Eden Prairie: 11000 W. 78th Street, Suite 100, Eden Prairie, MN 55344, (612) 828-9300.

MISSOURI: St. Louis: 12412 Powerscourt Drive, Suite 125, St. Louis, MO 63131, (314) 821-8400.

NEW JERSEY: Iselin: Metropolitan Corporate Plaza, 485 Bldg E. U.S. 1 South, Iselin, NJ 08830, (908) 750-1050.

NEW MEXICO: Albuquerque: 2709 J. Pan American Freeway, N.E., Albuquerque, NM 87101, (505) 345-2555.

NEW YORK: East Syracuse: 6365 Collamer Drive, East Syracuse, NY 13057, (315) 463-9291;

Fishkill: 300 Westage Business Center, Suite 140, Fishkill, NY 12524, (914) 897-2900;

Melville: 48 South Service Road, Suite 100, Melville, NY 11747, (516) 454-6601;

Pittsford: 2851 Clover Street, Pittsford, NY 14534, (716) 385-6770.

NORTH CAROLINA: Charlotte: 8 Woodlawn Green, Suite 100, Charlotte, NC 28217, (704) 527-0930;

Raleigh: 2809 Highwoods Boulevard, Suite 100,

Raleigh, NC 27625, (919) 876-2725.

OHIO: Beachwood: 23775 Commerce Park Road, Beachwood, OH 44122-5875, (216) 765-7258;

Beavercreek: 4200 Colonel Glenn Highway, Suite 600, Beavercreek, OH 45431, (513) 427-6200.

OREGON: Beaverton: 6700 S.W. 105th Street, Suite 110, Beaverton, OR 97005, (503) 643-6758.

PENNSYLVANIA: Blue Bell: 670 Sentry Parkway, Suite 200, Blue Bell, PA 19422, (215) 825-9500.

PUERTO RICO: Hato Rey: 615 Mercantile Plaza Building, Suite 505, Hato Rey, PR 00919, (809) 753-8700.

TEXAS: Austin: 12501 Research Boulevard, Austin, TX 78759, (512) 250-6769;

Dallas: 7839 Churchill Way, Dallas, TX 75251, (214) 917-1264;

Houston: 9301 Southwest Freeway, Commerce Park, Suite 360, Houston, TX 77074, (713) 778-6592;

Midland: FM 1788 & I-20, Midland, TX 79711-0448, (915) 561-7137.

UTAH: Salt Lake City: 2180 South 1300 East, Suite 335, Salt Lake City, UT 54106, (801) 466-8972.

WISCONSIN: Waukesha: 20825 Swenson Drive, Suite 900, Waukesha WI 53186, (414) 798-1001.

CANADA: Nepean: 301 Moodie Drive, Suite 102, Mallom Center, Nepean, Ontario, Canada K2H 9C4,

(613) 726-1970;

Richmond Hill: 280 Centre Street East, Richmond Hill, Ontario, Canada L4C 1B1, (416) 884-9181;

St. Laurent: 9460 Trans Canada Highway, St. Laurent, Quebec, Canada H4S 1R7, (514) 335-8392.

AUSTRALIA (& NEW ZEALAND): Texas Instruments Australia Ltd., 6-10 Talavera Road, North Ryde (Sydney), New South Wales, Australia 2113, 2-878-9000; 14th Floor, 380 Street, Kilda Road, Melbourne, Victoria, Australia 3004, 3-696-1211; 171 Philip Highway, Elizabeth, South Australia 5112, 8 255-2066.

BELGIUM: Texas Instruments Belgium S.A./N.V., Avenue Jules Bordetlaan 11, 1140 Brussels, Belgium, (02) 242 30 80.

BRAZIL: Texas Instruments Electronicos do Brasil Ltda., Av. Eng. Luiz Carlos Berrini 1461-11o andar, 04571, Sao Paulo, SP, Brazil, 11-535-5133.

DENMARK: Texas Instruments A/S, Borupvang 2D, 2750 Ballerup, Denmark, (44) 68 74 00.

FINLAND: Texas Instruments OY, Ahertajantie 3, P.O. Box 86, 02321 Espoo, Finland, (0) 802 6517.

FRANCE: Texas Instruments France, 8-10 Avenue Morane-Saulnier, B.P. 67, 78141 Velizy Villacoublay Cedex, France, (1) 30 70 1003.

GERMANY: Texas Instruments Deutschland GmbH., Haggertystrasse 1, 8050 Freising, (08161) 80-0; Kurfurstendamm 195-196, 1000 Berlin 15, (030) 8 82 73 65; Dusseldorfer Strasse 40, 6236 Eschborn 1, (06196) 80 70; Kirchhorster Strasse 2, 3000 Hannover 51, (0511) 64 68-0; Maybachstrasse 11, 7302 Ostfildern 2 (Nellingen), (0711) 3403257; Gildehofcenter, Hollestrasses 3, 4300 Essen 1, (0201) 24 25-0.

HOLLAND: Texas Instruments Holland B.V., Hoogehilweg 19, Postbus 12995, 1100 AZ Amsterdam-Zuidoost, Holland, (020) 5602911.

HONG KONG: Texas Instruments Hong Kong Ltd., 8th Floor, World Shipping Center, 7 Canton Road, Kowloon, Hong Kong, 737-0338.

HUNGARY: Texas Instruments Representation, Budaorsi ut.42, 1112 Budapest, Hungary, (1) 1 66 66 17.

IRELAND: Texas Instruments Ireland Ltd., 7/8 Harcourt Street, Dublin 2, Ireland, (01) 755233.

ITALY: Texas Instruments Italia S.p.a., Centro Direzionale Colleoni, Palazzo Perseo-Via Paracelso 12, 20041 Agrate Brianza (Mi), Italy, (039) 63221; Via Castello della Magliana, 38, 00148 Roma, Italy (06) 6572651; Via Amendola, 17, 40100 Bologna, Italy (051) 554004.

JAPAN: Texas Instruments Japan Ltd., Aoyama Fuji Building 3-6-12 Kita-Aoyama Minato-ku, Tokyo, Japan 107, 03-498-2111; MS Shibaura Building 9F, 4-13-23 Shibaura, Minato-ku, Tokyo, Japan 108, 03-769-8700; Nissho-wai Building 5F, 2-5-8 Imabashi, Chuou-ku, Osaka, Japan 541, 06-204-1881; Dai-ni Toyota Building Nishi-kan 7F, 4-10-27 Meieki, Nakamura-ku, Nagoya, Japan 450, 052-583-8691; Kanazawa Oyama-cho Daiichi Seimei Building 6F, 3-10 Oyama-cho, Kanazawa, Ishikawa, Japan 920, 0762-23-5471; Matsumoto Showa Building 6F, 1-2-11 Fukashi, Matsumoto, Nagano, Japan 390, 0263-33-1060; Daiichi Olympic Tachikawa Building 6F, 1-25-12, Akebono-cho, Tachikawa, Tokyo, Japan 190, 0425-27-6760; Yokohama Business Park East Tower 10F, 134 Goudo-cho Hodogaya-ku, Yokohama-shi, Kanagawa, Japan 240, 045-338-1220; Nihon Seimei Kyoto Yasaka Building 5F, 843-2, Higashi Shiohohji-cho, Higashi-iru, Nishinotoh-in, Shiohohji-dori, Shimogyo-ku, Kyoto, Japan 600, 075-341-7713; Sumitomo Seimei Kumagaya Building 8F, 2-44 Yavoi, Kumagaya, Saitama, Japan 360, 0485-22-2440; 2597-1, Aza Harudai, Oaza Yasaka, Kitsuki, Oita, Japan 873, 09786-3-3211.

KOREA: Texas Instruments Korea Ltd., 28th Floor, Trade Tower, 159, Samsung-Dong, Kangnam-ku Seoul, Korea, 2 551-2800.

MALAYSIA: Texas Instruments Malaysia, Sdn. Bhd., Asia Pacific, Lot 36.1 #Box 93, Menara Maybank, 100 Jalan Tun Perak, 50050 Kuala Lumpur, Malaysia, 2306001.

MEXICO: Texas Instruments de Mexico S.A., de C.V., Alfonso Reyes 115, Col. Hipodromo Condesa, Mexico, D.F., Mexico 06170, 5-515-6081.

NORWAY: Texas Instruments Norge A/S, P.B. 106, Refstad (Sinsenveien 53), 0513 Oslo 5, Norway, (02) 155 090.

PEOPLE'S REPUBLIC OF CHINA: Texas Instruments China Inc., Beijing Representative Office, 7-05 CITIC Building, 19 Jianguomenwai Dajie, Beijing, China, 500-2255, Ext. 7500.

PHILIPPINES: Texas Instruments Asia Ltd., Philippines Branch, 14th Floor, Ba-Lepanto Building, Paseo de Roxas, Makati, Metro Manila, Philippines, 2-8176031.

PORTUGAL: Texas Instruments Equipamento Electronico (Portugal) Ltda., Ing. Frederico Ulricho, 2650 Moreira Da Maia, 4470 Maia, Portugal (2) 948 1003.

SINGAPORE (& INDIA, INDONESIA, MALAYSIA, THAILAND): Texas Instruments Singapore (PTE) Ltd., Asia Pacific, 101 Thomson Road, #23-01, United Square, Singapore 1130, 3508100.

SPAIN: Texas Instruments Espana S.A., c/Gobelos 43, Urbanizacion, La Florida, 28023, Madrid, Spain, (1) 372 8051; c/Diputacion, 279-3-5, 08007 Barcelona, Spain, (3) 317 91 80.

SWEDEN: Texas Instruments International Trade Corporation (Sverigefilialen), Isafjordsgatan, Box 30, S-164 93 Kista, Sweden, (08) 752 58 00.

SWITZERLAND: Texas Instruments Switzerland AG, Riedstrasse 6, C8953 Dietikon, Switzerland, (01) 744 2811.

TAIWAN: Texas Instruments Taiwan Limited, Taipei Branch, 10th Floor Bank Tower, 205 Tung Hwa N. Road, Taipei, Taiwan, 10592 Republic of China, 2-7139311.

TURKEY: Texas Instruments, DSEG MidEast Regional Marketing Office, Karum Center, Suite 442, Iran Caddesi 21, 06680 Kavaklidere, Ankara, Turkey, 4-468-0155.

UNITED KINGDOM: Texas Instruments Ltd., Manton Lane, Bedford, England, MK41 7PA, (0234) 270 111.

TI Authorized North American Distributors

Alliance Electronics, Inc. (military product only)

Almac/Arrow

Anthem Electronics

Arrow/Schweber

Future Electronics (Canada)

GRS Electronics Co., Inc. *

Hall-Mark Electronics

Marshall Industries

Newark Electronics *

Wyle Laboratories

Zeus Components

Rochester Electronics, Inc. (obsolete product only)

*Not authorized for TI military products



TI North American Sales Offices

ALABAMA: Huntsville: (205) 837-7530
ARIZONA: Phoenix: (602) 995-1007
CALIFORNIA: Irvine: (714) 660-1200
San Diego: (619) 278-9600
Santa Clara: (408) 980-9000
Woodland Hills: (818) 704-8100
COLORADO: Aurora: (303) 368-8000
CONNECTICUT: Wallingford: (203) 269-0074
FLORIDA: Altamonte Springs: (407) 260-2116
Fort Lauderdale: (305) 973-8502
Tampa: (813) 885-7588
GEORGIA: Norcross: (404) 662-7967
ILLINOIS: Arlington Heights: (708) 640-3000
INDIANA: Carmel: (317) 573-6400
Fort Wayne: (219) 489-4697
KANSAS: Overland Park: (913) 451-4511
MARYLAND: Columbia: (410) 964-2003
MASSACHUSETTS: Waltham: (617) 895-9100
MICHIGAN: Farmington Hills: (313) 553-1581
MINNESOTA: Eden Prairie: (612) 828-9300
MISSOURI: St. Louis: (314) 821-8400
NEW JERSEY: Iselin: (908) 750-1050
NEW MEXICO: Albuquerque: (505) 345-2555
NEW YORK: East Syracuse: (315) 463-9291
Fishkill: (914) 897-2900
Melville: (516) 454-6600
Pittsford: (716) 385-6770
NORTH CAROLINA: Charlotte: (704) 527-0930
Raleigh: (919) 876-2725
OHIO: Beachwood: (216) 765-7258
Beavercreek: (513) 427-6200
OREGON: Beaverton: (503) 643-6758
PENNSYLVANIA: Blue Bell: (215) 825-9500
PUERTO RICO: Hato Rey: (809) 753-8700
TEXAS: Austin: (512) 250-6769
Dallas: (214) 917-1264
Houston: (713) 778-6592
Midland: (915) 561-7137
UTAH: Salt Lake City: (801) 466-8972
WISCONSIN: Waukesha: (414) 798-1001
CANADA: Nepean: (613) 726-1970
Richmond Hill: (416) 884-9181
St. Laurent: (514) 335-8392

TI Regional Technology Centers

CALIFORNIA: Irvine: (714) 660-8140
Santa Clara: (408) 748-2222
GEORGIA: Norcross: (404) 662-7945
ILLINOIS: Arlington Heights: (708) 640-2909
INDIANA: Indianapolis: (317) 573-6400
MASSACHUSETTS: Waltham: (617) 895-9196
MEXICO: Mexico City: 491-70834
MINNESOTA: Minneapolis: (612) 828-9300
TEXAS: Dallas: (214) 917-3881
CANADA: Nepean: (613) 726-1970

Customer Response Center

TOLL FREE: (800) 336-5236
OUTSIDE USA: (214) 995-6611
(8:00 a.m. – 5:00 p.m. CST)

TI Authorized North American Distributors

Alliance Electronics, Inc. (military product only)
Almac/Arrow
Anthem Electronics
Arrow/Schweber
Future Electronics (Canada)
GRS Electronics Co., Inc.
Hall-Mark Electronics
Marshall Industries
Newark Electronics
Rochester Electronics, Inc.
(obsolete product only) (508) 462-9332
Wyle Laboratories
Zeus Components

TI Distributors

ALABAMA: Arrow/Schweber (205) 837-6955; Hall-Mark (205) 837-8700; Marshall (205) 881-9235.
ARIZONA: Anthem (602) 966-6600; Arrow/Schweber (602) 437-0750; Hall-Mark (602) 431-0030; Marshall (602) 496-0290; Wyle (602) 437-2088.
CALIFORNIA: Los Angeles/Orange County: Anthem (818) 775-1333, (714) 768-4444; Arrow/Schweber (818) 380-9686, (714) 838-5422; Hall-Mark (818) 773-4500, (714) 727-6000; Marshall (818) 878-7000, (714) 458-5301; Wyle (818) 880-9000, (714) 863-9953; Zeus (714) 921-9000, (818) 889-3838;
Sacramento: Anthem (916) 624-9744; Hall-Mark (916) 624-9781; Marshall (916) 635-9700; Wyle (916) 638-5282;
San Diego: Anthem (619) 453-9005; Arrow/Schweber (619) 565-4800; Hall-Mark (619) 268-1201; Marshall (619) 578-9600; Wyle (619) 565-9171; Zeus (619) 277-9681.
San Francisco Bay Area: Anthem (408) 453-1200; Arrow/Schweber (408) 441-9700, (510) 490-9477; Hall-Mark (408) 432-4000; Marshall (408) 942-4600; Wyle (408) 727-2500; Zeus (408) 629-4789.
COLORADO: Anthem (303) 790-4500; Arrow/Schweber (303) 799-0258; Hall-Mark (303) 790-1662; Marshall (303) 451-8383; Wyle (303) 457-9953.
CONNECTICUT: Anthem (203) 575-1575; Arrow/Schweber (203) 265-7741; Hall-Mark (203) 271-2844; Marshall (203) 265-3822.
FLORIDA: Fort Lauderdale: Arrow/Schweber (305) 429-8200; Hall-Mark (305) 971-9280; Marshall (305) 977-4880.
Orlando: Arrow/Schweber (407) 333-9300; Hall-Mark (407) 830-5855; Marshall (407) 767-8585; Zeus (407) 788-9100.
Tampa: Hall-Mark (813) 541-7440; Marshall (813) 573-1399.
GEORGIA: Arrow/Schweber (404) 497-1300; Hall-Mark (404) 623-4400; Marshall (404) 923-5750.
ILLINOIS: Anthem (708) 884-0200; Arrow/Schweber (708) 250-0500; Hall-Mark (312) 860-3800; Marshall (708) 490-0155; Newark (312) 784-5100.
INDIANA: Arrow/Schweber (317) 299-2071; Hall-Mark (317) 872-8875; Marshall (317) 297-0483.
IOWA: Arrow/Schweber (319) 395-7230.
KANSAS: Arrow/Schweber (913) 541-9542; Hall-Mark (913) 888-4747; Marshall (913) 492-3121.
MARYLAND: Anthem (301) 995-6640; Arrow/Schweber (301) 596-7800; Hall-Mark (301) 988-9800; Marshall (301) 622-1118; Zeus (301) 997-1118.
MASSACHUSETTS: Anthem (508) 657-5170; Arrow/Schweber (508) 658-0900; Hall-Mark (508) 667-0902; Marshall (508) 658-0810; Wyle (617) 272-7300; Zeus (617) 246-8200.



MICHIGAN: Detroit: Arrow/Schweber (313) 462-2290; Hall-Mark (313) 416-5800; Marshall (313) 525-5850; Newark (313) 967-0600.
MINNESOTA: Anthem (612) 944-5454; Arrow/Schweber (612) 941-5280; Hall-Mark (612) 881-2600; Marshall (612) 559-2211.
MISSOURI: Arrow/Schweber (314) 567-6888; Hall-Mark (314) 291-5350; Marshall (314) 291-4650.
NEW JERSEY: Anthem (201) 227-7960; Arrow/Schweber (201) 227-7880, (609) 596-8000; Hall-Mark (201) 515-3000, (609) 235-1900; Marshall (201) 882-0320, (609) 234-9100.
NEW MEXICO: Alliance (505) 292-3360.
NEW YORK: Long Island: Anthem (516) 864-6600; Arrow/Schweber (516) 231-1000; Hall-Mark (516) 737-0600; Marshall (516) 273-2424; Zeus (914) 937-7400.
Rochester: Arrow/Schweber (716) 427-0300; Hall-Mark (716) 425-3300; Marshall (716) 235-7620.
Syracuse: Marshall (607) 785-2345.
NORTH CAROLINA: Arrow/Schweber (919) 876-3132; Hall-Mark (919) 872-0712; Marshall (919) 878-9882.
OHIO: Cleveland: Arrow/Schweber (216) 248-3990; Hall-Mark (216) 349-4632; Marshall (216) 248-1788.
Columbus: Hall-Mark (614) 888-3313.
Dayton: Arrow/Schweber (513) 435-5563; Marshall (513) 898-4480; Zeus (513) 293-6162.
OKLAHOMA: Arrow/Schweber (919) 252-7537; Hall-Mark (918) 254-6110.
OREGON: Almac/Arrow (503) 629-8090; Anthem (503) 643-1114; Marshall (503) 644-5050; Wyle (503) 643-7900.
PENNSYLVANIA: Anthem (215) 443-5150; Arrow/Schweber (215) 928-1800; GRS (215) 922-7037; (609) 964-8560; Marshall (412) 788-0441.
TEXAS: Austin: Arrow/Schweber (512) 835-4180; Hall-Mark (512) 258-8848; Marshall (512) 837-1991; Wyle (512) 345-8853;
Dallas: Anthem (214) 238-7100; Arrow/Schweber (214) 380-6464; Hall-Mark (214) 553-4300; Marshall (214) 233-5200; Wyle (214) 235-9953; Zeus (214) 783-7010;
Houston: Arrow/Schweber (713) 530-4700; Hall-Mark (713) 781-6100; Marshall (713) 467-1666; Wyle (713) 879-9953.
UTAH: Anthem (801) 973-8555; Arrow/Schweber (801) 973-6913; Marshall (801) 973-2288; Wyle (801) 974-9953.
WASHINGTON: Almac/Arrow (206) 643-9992; Anthem (206) 483-1700; Marshall (206) 486-5747; Wyle (206) 881-1150.
WISCONSIN: Arrow/Schweber (414) 792-0150; Hall-Mark (414) 797-7844; Marshall (414) 797-8400.
CANADA: Calgary: Future (403) 235-5325;
Edmonton: Future (403) 438-2858;
Montreal: Arrow/Schweber (514) 421-7411; Future (514) 694-7710; Marshall (514) 694-8142
Ottawa: Arrow/Schweber (613) 226-6903; Future (613) 820-8313.
Quebec: Future (418) 897-6666.
Toronto: Arrow/Schweber (416) 670-7769; Future (416) 612-9200; Marshall (416) 458-8046.
Vancouver: Arrow/Schweber (604) 421-2333; Future (604) 294-1166.

TI Die Processors

Chip Supply (407) 298-7100
Elmo Semiconductor (818) 768-7400
Minco Technology Labs (512) 834-2022

D0892

PACKAGING INFORMATION

Orderable Device	Status ⁽¹⁾	Package Type	Package Drawing	Pins	Package Qty	Eco Plan ⁽²⁾	Lead/Ball Finish	MSL Peak Temp ⁽³⁾
PAL22V10Z-25CJTL	ACTIVE	CDIP	JT	24	15	TBD	A42	N / A for Pkg Type
TICPAL22V10Z-25CFN	ACTIVE	PLCC	FN	28	37	TBD	CU	Level-1-220C-UNLIM
TICPAL22V10Z-25CNT	ACTIVE	PDIP	NT	24	15	Pb-Free (RoHS)	CU NIPDAU	N / A for Pkg Type

⁽¹⁾ The marketing status values are defined as follows:

ACTIVE: Product device recommended for new designs.

LIFEBUY: TI has announced that the device will be discontinued, and a lifetime-buy period is in effect.

NRND: Not recommended for new designs. Device is in production to support existing customers, but TI does not recommend using this part in a new design.

PREVIEW: Device has been announced but is not in production. Samples may or may not be available.

OBSOLETE: TI has discontinued the production of the device.

⁽²⁾ Eco Plan - The planned eco-friendly classification: Pb-Free (RoHS), Pb-Free (RoHS Exempt), or Green (RoHS & no Sb/Br) - please check <http://www.ti.com/productcontent> for the latest availability information and additional product content details.

TBD: The Pb-Free/Green conversion plan has not been defined.

Pb-Free (RoHS): TI's terms "Lead-Free" or "Pb-Free" mean semiconductor products that are compatible with the current RoHS requirements for all 6 substances, including the requirement that lead not exceed 0.1% by weight in homogeneous materials. Where designed to be soldered at high temperatures, TI Pb-Free products are suitable for use in specified lead-free processes.

Pb-Free (RoHS Exempt): This component has a RoHS exemption for either 1) lead-based flip-chip solder bumps used between the die and package, or 2) lead-based die adhesive used between the die and leadframe. The component is otherwise considered Pb-Free (RoHS compatible) as defined above.

Green (RoHS & no Sb/Br): TI defines "Green" to mean Pb-Free (RoHS compatible), and free of Bromine (Br) and Antimony (Sb) based flame retardants (Br or Sb do not exceed 0.1% by weight in homogeneous material)

⁽³⁾ MSL, Peak Temp. -- The Moisture Sensitivity Level rating according to the JEDEC industry standard classifications, and peak solder temperature.

Important Information and Disclaimer:The information provided on this page represents TI's knowledge and belief as of the date that it is provided. TI bases its knowledge and belief on information provided by third parties, and makes no representation or warranty as to the accuracy of such information. Efforts are underway to better integrate information from third parties. TI has taken and continues to take reasonable steps to provide representative and accurate information but may not have conducted destructive testing or chemical analysis on incoming materials and chemicals. TI and TI suppliers consider certain information to be proprietary, and thus CAS numbers and other limited information may not be available for release.

In no event shall TI's liability arising out of such information exceed the total purchase price of the TI part(s) at issue in this document sold by TI to Customer on an annual basis.

MECHANICAL DATA

NT (R-PDIP-T**) 24 PINS SHOWN

PLASTIC DUAL-IN-LINE PACKAGE

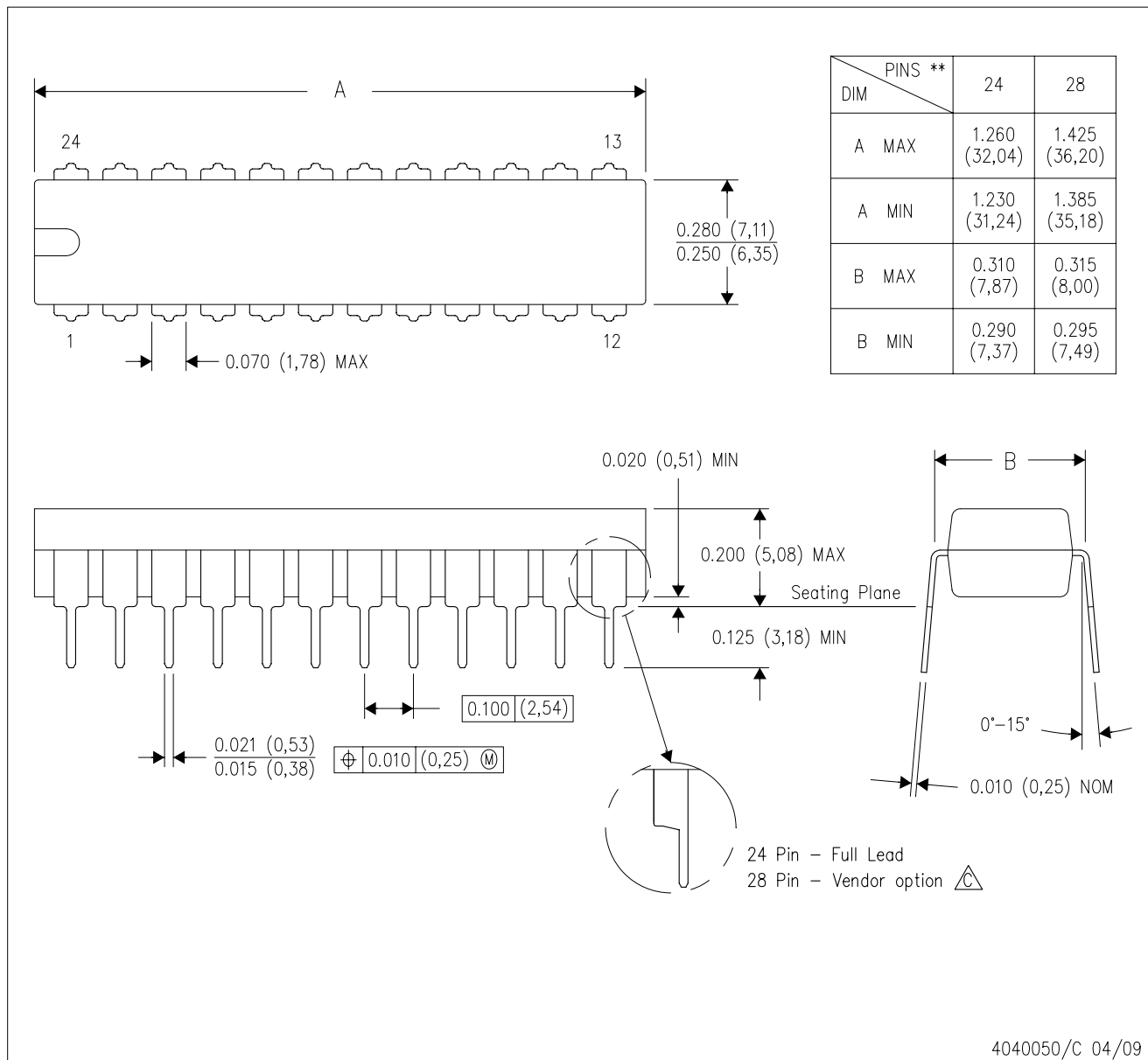

4040050/C 04/09

- NOTES:
- A. All linear dimensions are in millimeters. Dimensioning and tolerancing per ASME Y14.5M-1994.
 - B. This drawing is subject to change without notice.
 -  The 28 pin end lead shoulder width is a vendor option, either half or full width.

FN (S-PQCC-J**)

PLASTIC J-LEADED CHIP CARRIER

20 PIN SHOWN

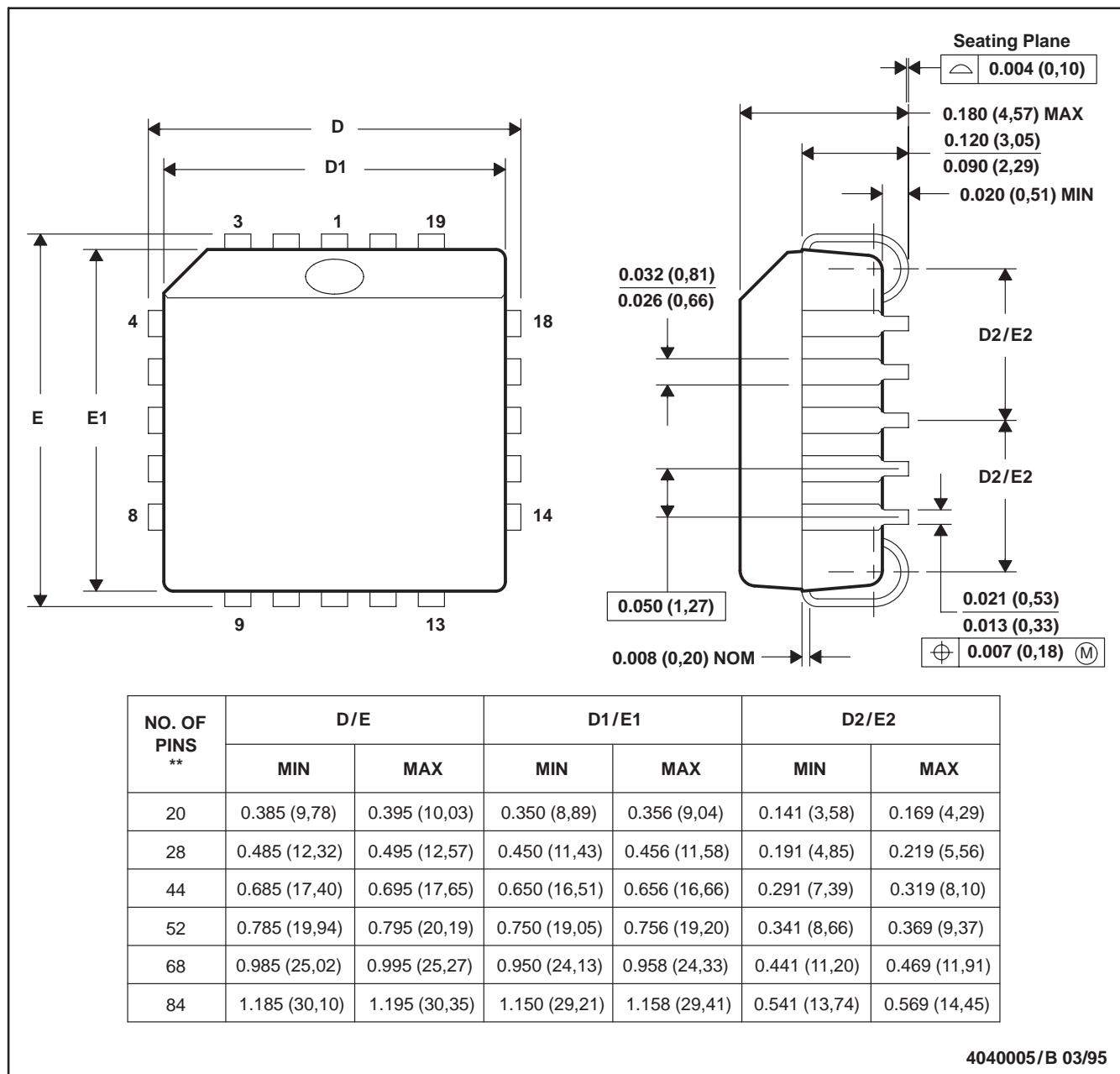

- NOTES: A. All linear dimensions are in inches (millimeters).
 B. This drawing is subject to change without notice.
 C. Falls within JEDEC MS-018

JT (R-GDIP-T**)

CERAMIC DUAL-IN-LINE

24 LEADS SHOWN

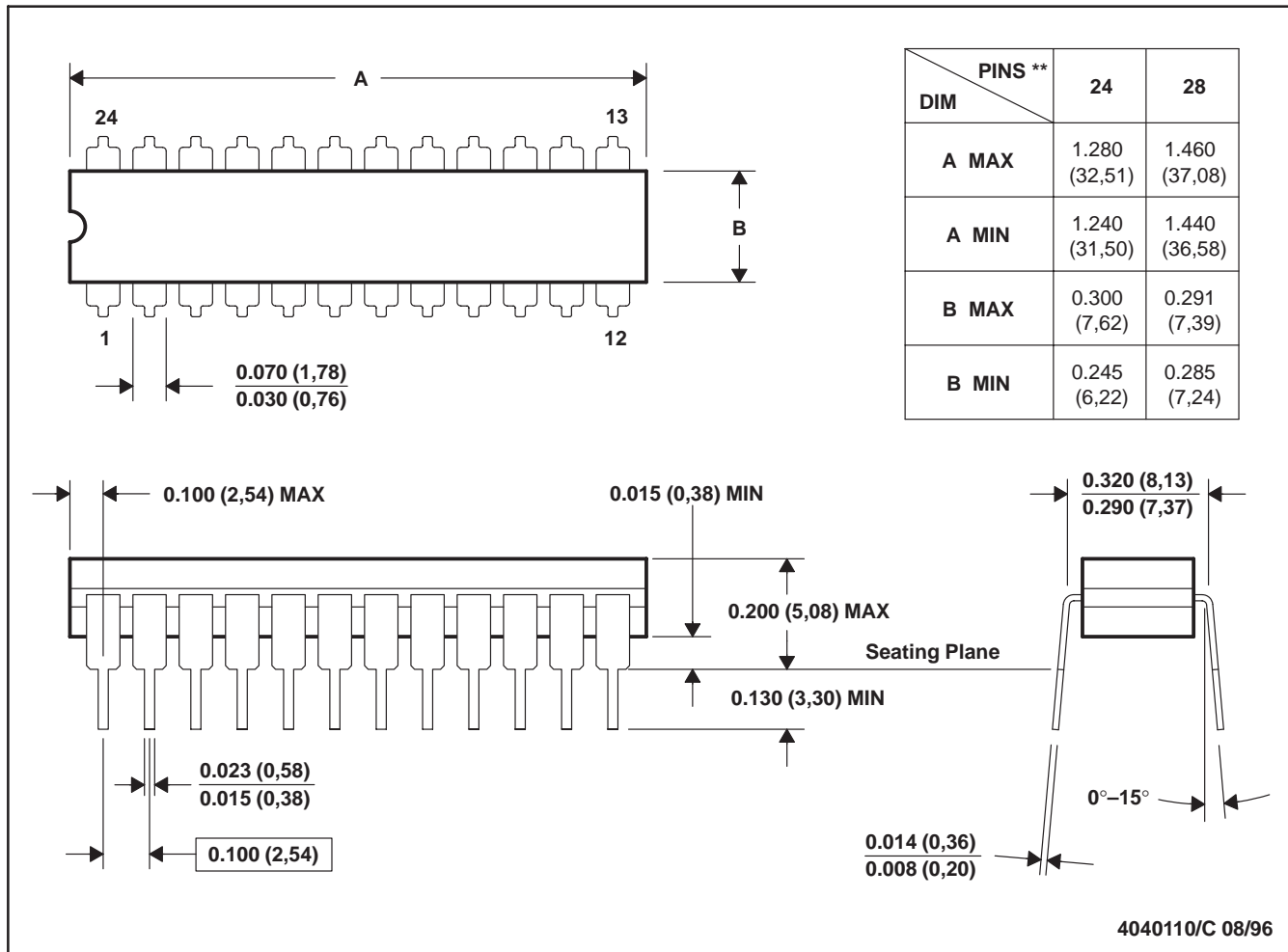

4040110/C 08/96

- NOTES: A. All linear dimensions are in inches (millimeters).
 B. This drawing is subject to change without notice.
 C. This package can be hermetically sealed with a ceramic lid using glass frit.
 D. Index point is provided on cap for terminal identification.
 E. Falls within MIL STD 1835 GDIP3-T24, GDIP4-T28, and JEDEC MO-058 AA, MO-058 AB

IMPORTANT NOTICE

Texas Instruments Incorporated and its subsidiaries (TI) reserve the right to make corrections, modifications, enhancements, improvements, and other changes to its products and services at any time and to discontinue any product or service without notice. Customers should obtain the latest relevant information before placing orders and should verify that such information is current and complete. All products are sold subject to TI's terms and conditions of sale supplied at the time of order acknowledgment.

TI warrants performance of its hardware products to the specifications applicable at the time of sale in accordance with TI's standard warranty. Testing and other quality control techniques are used to the extent TI deems necessary to support this warranty. Except where mandated by government requirements, testing of all parameters of each product is not necessarily performed.

TI assumes no liability for applications assistance or customer product design. Customers are responsible for their products and applications using TI components. To minimize the risks associated with customer products and applications, customers should provide adequate design and operating safeguards.

TI does not warrant or represent that any license, either express or implied, is granted under any TI patent right, copyright, mask work right, or other TI intellectual property right relating to any combination, machine, or process in which TI products or services are used. Information published by TI regarding third-party products or services does not constitute a license from TI to use such products or services or a warranty or endorsement thereof. Use of such information may require a license from a third party under the patents or other intellectual property of the third party, or a license from TI under the patents or other intellectual property of TI.

Reproduction of TI information in TI data books or data sheets is permissible only if reproduction is without alteration and is accompanied by all associated warranties, conditions, limitations, and notices. Reproduction of this information with alteration is an unfair and deceptive business practice. TI is not responsible or liable for such altered documentation. Information of third parties may be subject to additional restrictions.

Resale of TI products or services with statements different from or beyond the parameters stated by TI for that product or service voids all express and any implied warranties for the associated TI product or service and is an unfair and deceptive business practice. TI is not responsible or liable for any such statements.

TI products are not authorized for use in safety-critical applications (such as life support) where a failure of the TI product would reasonably be expected to cause severe personal injury or death, unless officers of the parties have executed an agreement specifically governing such use. Buyers represent that they have all necessary expertise in the safety and regulatory ramifications of their applications, and acknowledge and agree that they are solely responsible for all legal, regulatory and safety-related requirements concerning their products and any use of TI products in such safety-critical applications, notwithstanding any applications-related information or support that may be provided by TI. Further, Buyers must fully indemnify TI and its representatives against any damages arising out of the use of TI products in such safety-critical applications.

TI products are neither designed nor intended for use in military/aerospace applications or environments unless the TI products are specifically designated by TI as military-grade or "enhanced plastic." Only products designated by TI as military-grade meet military specifications. Buyers acknowledge and agree that any such use of TI products which TI has not designated as military-grade is solely at the Buyer's risk, and that they are solely responsible for compliance with all legal and regulatory requirements in connection with such use.

TI products are neither designed nor intended for use in automotive applications or environments unless the specific TI products are designated by TI as compliant with ISO/TS 16949 requirements. Buyers acknowledge and agree that, if they use any non-designated products in automotive applications, TI will not be responsible for any failure to meet such requirements.

Following are URLs where you can obtain information on other Texas Instruments products and application solutions:

Products

Amplifiers	amplifier.ti.com
Data Converters	dataconverter.ti.com
DLP® Products	www.dlp.com
DSP	dsp.ti.com
Clocks and Timers	www.ti.com/clocks
Interface	interface.ti.com
Logic	logic.ti.com
Power Mgmt	power.ti.com
Microcontrollers	microcontroller.ti.com
RFID	www.ti-rfid.com
RF/IF and ZigBee® Solutions	www.ti.com/lprf

Applications

Audio	www.ti.com/audio
Automotive	www.ti.com/automotive
Broadband	www.ti.com/broadband
Digital Control	www.ti.com/digitalcontrol
Medical	www.ti.com/medical
Military	www.ti.com/military
Optical Networking	www.ti.com/opticalnetwork
Security	www.ti.com/security
Telephony	www.ti.com/telephony
Video & Imaging	www.ti.com/video
Wireless	www.ti.com/wireless

Mailing Address: Texas Instruments, Post Office Box 655303, Dallas, Texas 75265
Copyright © 2009, Texas Instruments Incorporated