

Octal line driver

NE5170

DESCRIPTION

The NE5170 is an octal line driver which is designed for digital communications with data rates up to 100kb/s. This device meets all the requirements of EIA standards RS-232C/RS-423A and CCITT recommendations V.10/X.26. Three programmable features:

(1) output slew rate, (2) output voltage level, and (3) three-state control (high-impedance) are provided so that output characteristics may be modified to meet the requirements of specific applications.

FEATURES

- Meets EIA RS-232C/423A and CCITT V.10/X.26
- Simple slew rate programming with a single external resistor
- 0.1 to 10V/ μ s slew rate range
- High/low programmable voltage output modes
- TTL compatible inputs

APPLICATIONS

- High-speed modems
- High-speed parallel communications
- Computer I/O ports
- Logic level translation

PIN CONFIGURATION

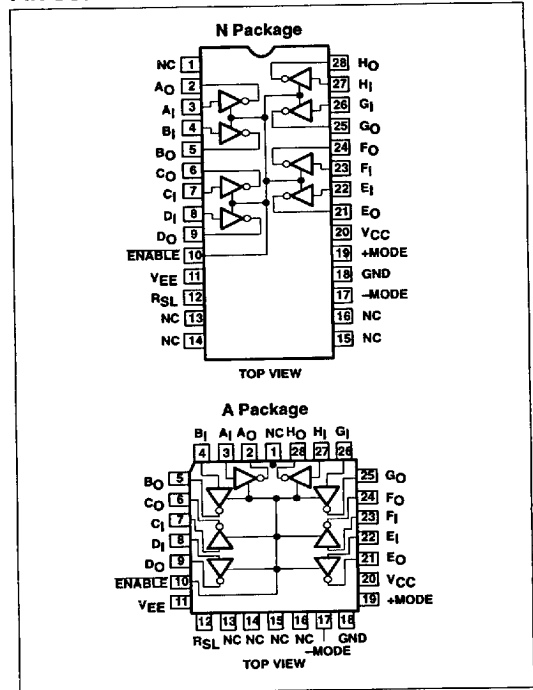

FUNCTION TABLE

ENABLE	Logic Input	OUTPUT VOLTAGE (V)		
		RS-423A ¹	RS-232C	
			Low Output Mode ¹	High Output Mode ²
L	L	5 to 6V	5 to 6V	≥ 9V
L	H	-5 to 6V	-5 to 6V	≤ -9V
H	X	High-Z	High-Z	High-Z

NOTES:

1. V_{CC} = +10V and V_{EE} = -10V; R_L = 3k Ω
2. V_{CC} = +12V and V_{EE} = -12V; R_L = 3k Ω

ORDERING INFORMATION

DESCRIPTION	TEMPERATURE RANGE	ORDER CODE	DWG #
28-Pin Plastic Dual In-Line (DIP) Package	0 to +70°C	NE5170N	0408B
28-Pin Plastic Lead Chip Carrier (PLCC) Package	0 to +70°C	NE5170A	0401F



Octal line driver

NE5170

ABSOLUTE MAXIMUM RATINGS

SYMBOL	PARAMETER	RATING	UNIT
V _{CC}	Supply voltage and + MODE	15	V
V _{EE}	Supply voltage and - MODE	-15	V
I _{OUT}	Output current ¹		mA
V _{IN}	Input voltage (Enable, Data)	-1.5 to +7	V
V _{OUT}	Output voltage ²	±15	V
	Minimum slew resistor ³	1	kΩ
P _D	Power dissipation	1200	mW

NOTES:

- Maximum current per driver. Do not exceed maximum power dissipation if more than one output is on.
- High impedance mode.
- Minimum value of the resistor used to set the slew rate.

DC ELECTRICAL CHARACTERISTICS

V_{CC} = 10V ±10%; V_{EE} = -10V ±10%; ±MODES = 0V; R_{SL} = 2kΩ, 0°C ≤ T_A ≤ 70°C, unless otherwise specified.

SYMBOL	PARAMETER	TEST CONDITIONS	LIMITS		UNIT
			Min	Max	
V _{OH}	Output high voltage	V _{IN} = 0.8V, R _L = 3kΩ ²	5	6	V
		R _L = 450Ω ²	4.5	6	
		R _L = 3kΩ ³ , C _L = 2500pF	V _{CC} -3		
V _{OL}	Output low voltage	V _{IN} = 2.0V, R _L = 3kΩ ²	-6	-5	V
		R _L = 450Ω ²	-6	-4.5	
		R _L = 3kΩ ³ , C _L = 2500pF		V _{EE} +3	
V _{OU}	Output unbalance voltage	V _{CC} = V _{EE} , R _L = 450Ω ²		0.4	V
I _{CEX}	Output leakage current	V _O = 6V, ENABLE = 2V or V _{CC} = V _{EE} = 0V	-100	100	μA
V _{IH}	Input high voltage		2.0		V
V _{IL}	Input low voltage			0.8	V
I _{IL}	Logic "0" input current	V _{IN} = 0.4V	-400	0	μA
I _{IH}	Logic "1" input current	V _{IN} = 2.4V	0	40	μA
I _{OS}	Output short circuit current ¹	V _O = 0V	-150	150	mA
V _{CL}	Input clamp voltage	I _{IN} = -15mA	-1.5		V
I _{CC}	Supply current	NO LOAD		35	mA
I _{EE}		NO LOAD	-45		mA

NOTES:

- Maximum current per driver. Do not exceed maximum power dissipation if more than one output is on.
- V_{OH}, V_{OL} at R_L = 450Ω will be ≥ 90% of V_{OH}, V_{OL} at R_L = ∞.
- High Output Mode: +MODE pin = V_{CC}; -MODE pin = V_{EE}; 9V ≤ V_{CC} ≤ 13V; -9V ≥ V_{EE} ≥ -13V.

Octal line driver

NE5170

AC ELECTRICAL CHARACTERISTICS

$V_{CC} = +10V$; $V_{EE} = -10V$; Mode = GND, $0^\circ C \leq T_A \leq 70^\circ C$

SYMBOL	PARAMETER	TEST CONDITIONS	LIMITS		UNIT
			Min	Max	
t_{PLZ}	Propagation delay output high to high impedance	$R_L = 450, C_L = 50pF$ or $R_L = 3k, C_L = 2500pF$		5	μs
t_{PLZ}	Propagation delay output low to high impedance	$R_L = 450, C_L = 50pF$ or $R_L = 3k, C_L = 2500pF$		5	μs
t_{pZH}	Propagation delay high impedance to high output	$R_{SL} = 200k$ $R_L = 450, C_L = 50pF$ or $R_L = 3k, C_L = 2500pF$		150	μs
t_{pZL}	Propagation delay high impedance to low output	$R_{SL} = 200k$ $R_L = 450, C_L = 50pF$ or $R_L = 3k, C_L = 2500pF$		150	μs
SR	Output slew rate	$R_{SL} = 2k$	8	12	V/ μs
		$R_{SL} = 20k$	0.8	1.2	
		$R_{SL} = 200k$	0.06	0.14	

NOTE:

SR: Load condition. (A) For $R_{SL} < 4k\Omega$ use $R_L = 450\Omega$; $C_L = 50pF$; (B) for $R_{SL} > 4k\Omega$ use either $R_L = 450\Omega$, $C_L = 50pF$ or $R_L = 3k\Omega$, $C_L = 2500pF$.

AC PARAMETER TEST CIRCUIT AND WAVEFORMS

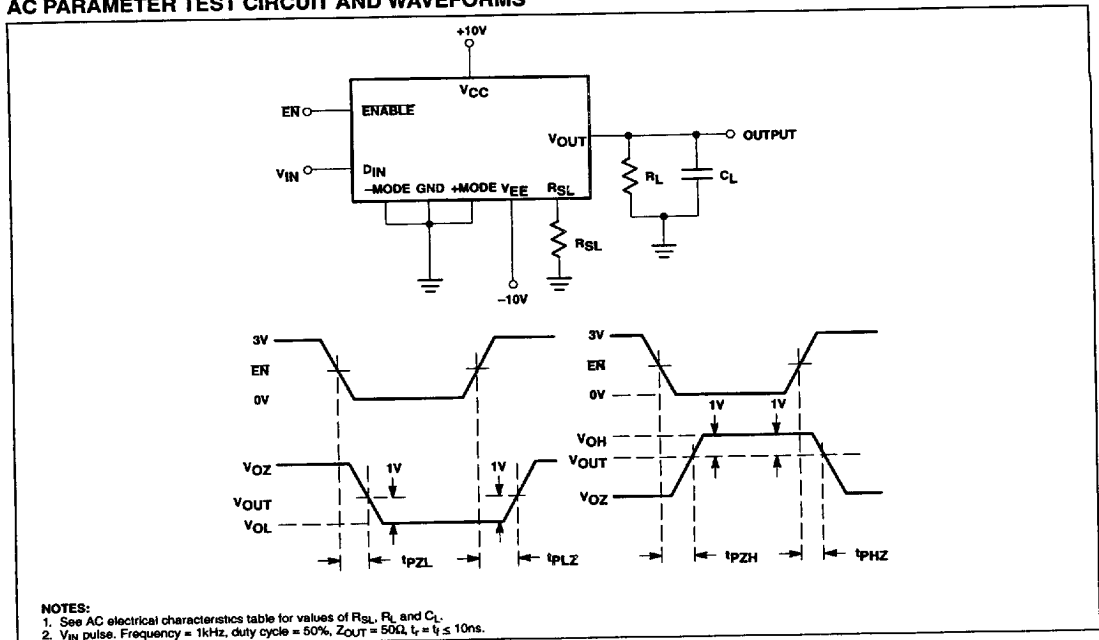

Octal line driver

NE5170

SLEW RATE PROGRAMMING

Slew rate for the NE5170 is set using a single external resistor connected between the R_{SL} pin and ground. Adjustment is made according to the formula:

$$R_{SL} \text{ (in k}\Omega\text{)} = \frac{20}{\text{Slew Rate}}$$

where the slew rate is in V/ μ s. The slew resistor can vary between 2 and 200k Ω which gives a slew rate range of 10 to 0.1V/ μ s. This adjustment of the slew rate allows tailoring output characteristics to recommendations for cable length and data rate found in EIA standard RS-423A. Approximations for cable length and data rate are given by:

$$\text{Max. data rate (in kb/s)} = 300/t$$

$$\text{Cable length (in feet)} = 100 \cdot t$$

where t is the rise time in microseconds. The absolute maximum data rate is 100kb/s and the absolute maximum cable length is 4000 feet.

OUTPUT MODE PROGRAMMING

The NE5170 has two programmable output modes which provide different output voltage levels. The low output mode meets the specifications of EIA standards RS-423A and RS-232C. The high output mode meets the specifications of RS-232C only, since higher output voltages result from programming this mode. The high output mode provides the greater output voltages where higher attenuation levels must be tolerated. Programming the high output mode is accomplished by connecting the +MODE pin to V_{CC} and the -MODE pin to V_{EE}. The low output mode results when both of these pins are connected to ground.

APPLICATION

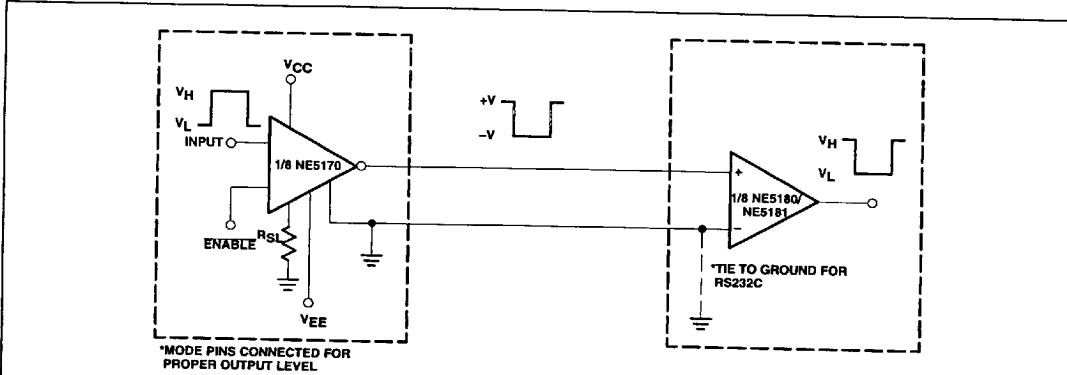

Figure 1. RS-232C/RS-423A Data Transmission

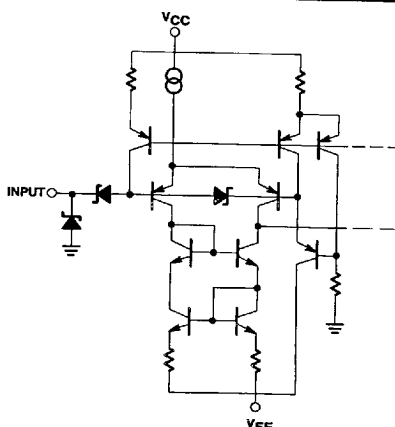

Figure 2. Input Stage Schematic

Octal line driver

NE5170

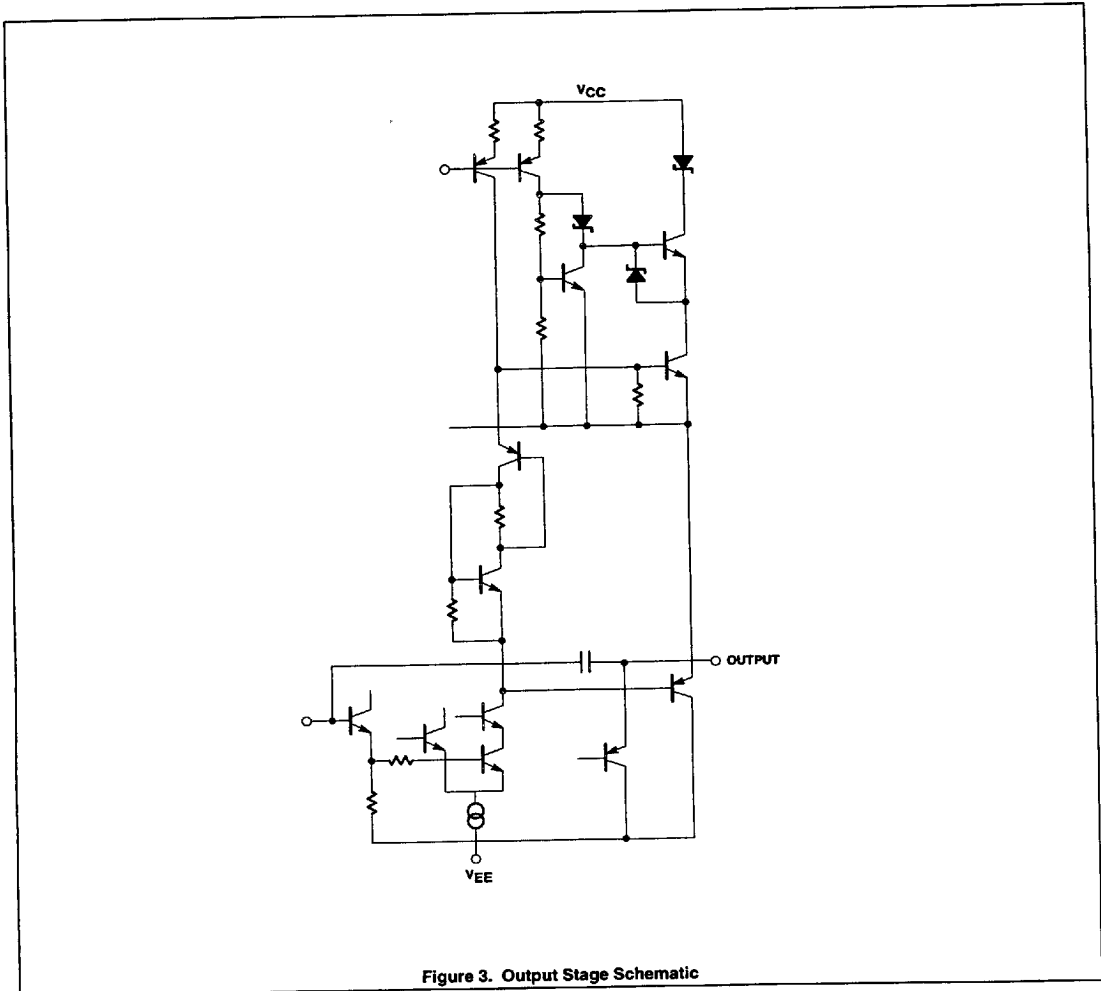

Figure 3. Output Stage Schematic

Octal line driver

NE5170

