

MCF52223

MCF52223 ColdFire Microcontroller

Supports MCF52223 & MCF52221

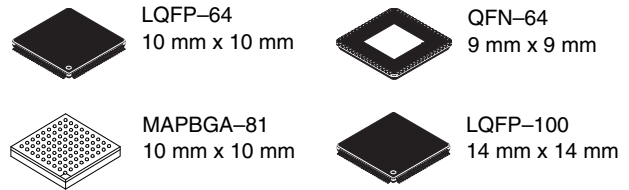

The MCF52223 is a member of the ColdFire[®] family of reduced instruction set computing (RISC) microprocessors.

This document provides an overview of the 32-bit MCF52223 microcontroller, focusing on its highly integrated and diverse feature set.

This 32-bit device is based on the Version 2 ColdFire core operating at a frequency up to 80 MHz, offering high performance and low power consumption. On-chip memories connected tightly to the processor core include up to 256 Kbytes of flash memory and 32 Kbytes of static random access memory (SRAM). On-chip modules include:

- V2 ColdFire core delivering 76 MIPS (Dhrystone 2.1) at 80 MHz running from internal flash memory with Multiply Accumulate (MAC) Unit and hardware divider
- Universal Serial Bus On-The-Go (USBOTG)
- USB Transceiver
- Three universal asynchronous/synchronous receiver/transmitters (UARTs)
- Inter-integrated circuit (I2C[™]) bus controller
- Queued serial peripheral interface (QSPI) module
- Eight-channel 12-bit fast analog-to-digital converter (ADC)
- Four-channel direct memory access (DMA) controller
- Four 32-bit input capture/output compare timers with DMA support (DTIM)
- Four-channel general-purpose timer (GPT) capable of input capture/output compare, pulse width modulation (PWM), and pulse accumulation
- Eight-channel/Four-channel, 8-bit/16-bit pulse width modulation timer
- Two 16-bit periodic interrupt timers (PITs)
- Real-time clock (RTC) module
- Programmable software watchdog timer
- Interrupt controller capable of handling 57 sources
- Clock module with 8 MHz on-chip relaxation oscillator and integrated phase-locked loop (PLL)
- Test access/debug port (JTAG, BDM)

This document contains information on a product under development. Freescale reserves the right to change or discontinue this product without notice.

© Freescale Semiconductor, Inc., 2007. All rights reserved.

Table of Contents

| | | |
|------|---|----|
| 1 | MCF52223 Family Configurations | 3 |
| 1.1 | Block Diagram | 4 |
| 1.2 | Features | 4 |
| 1.3 | Reset Signals | 21 |
| 1.4 | PLL and Clock Signals | 21 |
| 1.5 | Mode Selection | 21 |
| 1.6 | External Interrupt Signals | 22 |
| 1.7 | Queued Serial Peripheral Interface (QSPI) | 22 |
| 1.8 | USB On-the-Go | 22 |
| 1.9 | I ² C I/O Signals | 22 |
| 1.10 | UART Module Signals | 23 |
| 1.11 | DMA Timer Signals | 23 |
| 1.12 | ADC Signals | 23 |
| 1.13 | General Purpose Timer Signals | 24 |
| 1.14 | Pulse Width Modulator Signals | 24 |
| 1.15 | Debug Support Signals | 24 |
| 1.16 | EzPort Signal Descriptions | 25 |
| 1.17 | Power and Ground Pins | 26 |
| 2 | Electrical Characteristics | 26 |
| 2.1 | Maximum Ratings | 27 |
| 2.2 | Current Consumption | 28 |
| 2.3 | Thermal Characteristics | 29 |
| 2.4 | Flash Memory Characteristics | 31 |
| 2.5 | ESD Protection | 32 |
| 2.6 | DC Electrical Specifications | 32 |
| 2.7 | Clock Source Electrical Specifications | 33 |
| 2.8 | General Purpose I/O Timing | 34 |
| 2.9 | Reset Timing | 35 |
| 2.10 | I ² C Input/Output Timing Specifications | 36 |
| 2.11 | Analog-to-Digital Converter (ADC) Parameters | 37 |
| 2.12 | Equivalent Circuit for ADC Inputs | 38 |
| 2.13 | DMA Timers Timing Specifications | 39 |
| 2.14 | QSPI Electrical Specifications | 39 |
| 2.15 | JTAG and Boundary Scan Timing | 40 |
| 2.16 | Debug AC Timing Specifications | 42 |
| 3 | Mechanical Outline Drawings | 44 |
| 3.1 | 64-pin LQFP Package | 44 |
| 3.2 | 64 QFN Package | 47 |
| 3.3 | 81 MAPBGA Package | 51 |
| 3.4 | 100-pin LQFP Package | 53 |
| 4 | Revision History | 56 |

List of Figures

| | | |
|-----------|--|----|
| Figure 1. | MCF52223 Block Diagram | 4 |
| Figure 2. | 100 LQFP Pin Assignments | 13 |
| Figure 3. | 81 MAPBGA Pin Assignments | 14 |
| Figure 4. | 64 LQFP and 64 QFN Pin Assignments | 15 |
| Figure 5. | GPIO Timing | 35 |
| Figure 6. | RSTI and Configuration Override Timing | 35 |

| | | |
|------------|---------------------------------------|----|
| Figure 7. | I ² C Input/Output Timings | 37 |
| Figure 8. | Equivalent Circuit for A/D Loading | 38 |
| Figure 9. | QSPI Timing | 39 |
| Figure 10. | Test Clock Input Timing | 40 |
| Figure 11. | Boundary Scan (JTAG) Timing | 41 |
| Figure 12. | Test Access Port Timing | 41 |
| Figure 13. | TRST Timing | 41 |
| Figure 14. | Real-Time Trace AC Timing | 42 |
| Figure 15. | BDM Serial Port AC Timing | 43 |

List of Tables

| | | |
|-----------|---|----|
| Table 1. | MCF52223 Family Configurations | 3 |
| Table 2. | Pin Functions by Primary and Alternate Purpose | 16 |
| Table 3. | Reset Signals | 21 |
| Table 4. | PLL and Clock Signals | 21 |
| Table 5. | Mode Selection Signals | 21 |
| Table 6. | Clocking Modes | 21 |
| Table 7. | External Interrupt Signals | 22 |
| Table 8. | Queued Serial Peripheral Interface (QSPI) Signals | 22 |
| Table 9. | I ² C I/O Signals | 22 |
| Table 10. | UART Module Signals | 23 |
| Table 11. | DMA Timer Signals | 23 |
| Table 12. | ADC Signals | 23 |
| Table 13. | GPT Signals | 24 |
| Table 14. | PWM Signals | 24 |
| Table 15. | Debug Support Signals | 24 |
| Table 16. | EzPort Signal Descriptions | 25 |
| Table 17. | Power and Ground Pins | 26 |
| Table 18. | Absolute Maximum Ratings | 27 |
| Table 19. | Current Consumption in Low-Power Mode | 28 |
| Table 20. | Typical Active Current Consumption Specifications | 29 |
| Table 21. | Thermal Characteristics | 29 |
| Table 22. | SGFM Flash Program and Erase Characteristics | 31 |
| Table 23. | SGFM Flash Module Life Characteristics | 31 |
| Table 24. | ESD Protection Characteristics | 32 |
| Table 25. | DC Electrical Specifications | 32 |
| Table 26. | PLL Electrical Specifications | 33 |
| Table 27. | GPIO Timing | 34 |
| Table 28. | Reset and Configuration Override Timing | 35 |
| Table 29. | I ² C Input Timing Specifications between I2C_SCL and I2C_SDA | 36 |
| Table 30. | I ² C Output Timing Specifications between I2C_SCL and I2C_SDA | 36 |
| Table 31. | ADC Parameters | 37 |
| Table 32. | Timer Module AC Timing Specifications | 39 |
| Table 33. | QSPI Modules AC Timing Specifications | 39 |
| Table 34. | JTAG and Boundary Scan Timing | 40 |
| Table 35. | Debug AC Timing Specification | 42 |
| Table 36. | Revision History | 56 |

1 MCF52223 Family Configurations

Table 1. MCF52223 Family Configurations

| Module | 52221 | 52223 |
|---|----------------------|-----------------------|
| ColdFire Version 2 Core with MAC (Multiply-Accumulate Unit) | • | • |
| System Clock | 66, 80 MHz | |
| Performance (Dhrystone 2.1 MIPS) | up to 76 | |
| Flash / Static RAM (SRAM) | 128/16 Kbytes | 256/32 Kbytes |
| Interrupt Controller (INTC) | • | • |
| Fast Analog-to-Digital Converter (ADC) | • | • |
| USB On-The-Go (USB OTG) | • | • |
| Four-channel Direct-Memory Access (DMA) | • | • |
| Software Watchdog Timer (WDT) | • | • |
| Programmable Interrupt Timer | 2 | 2 |
| Four-Channel General Purpose Timer | • | • |
| 32-bit DMA Timers | 4 | 4 |
| QSPI | • | • |
| UART(s) | 3 | 3 |
| I ² C | • | • |
| Eight/Four-channel 8/16-bit PWM Timer | • | • |
| General Purpose I/O Module (GPIO) | • | • |
| Chip Configuration and Reset Controller Module | • | • |
| Background Debug Mode (BDM) | • | • |
| JTAG - IEEE 1149.1 Test Access Port ¹ | • | • |
| Package | 64 LQFP 81 MAPBGA | 81 MAPBGA 100 LQFP |

¹ The full debug/trace interface is available only on the 100-pin packages. A reduced debug interface is bonded on smaller packages.

1.1 Block Diagram

Figure 1 shows a top-level block diagram of the MCF52223. Package options for this family are described later in this document.

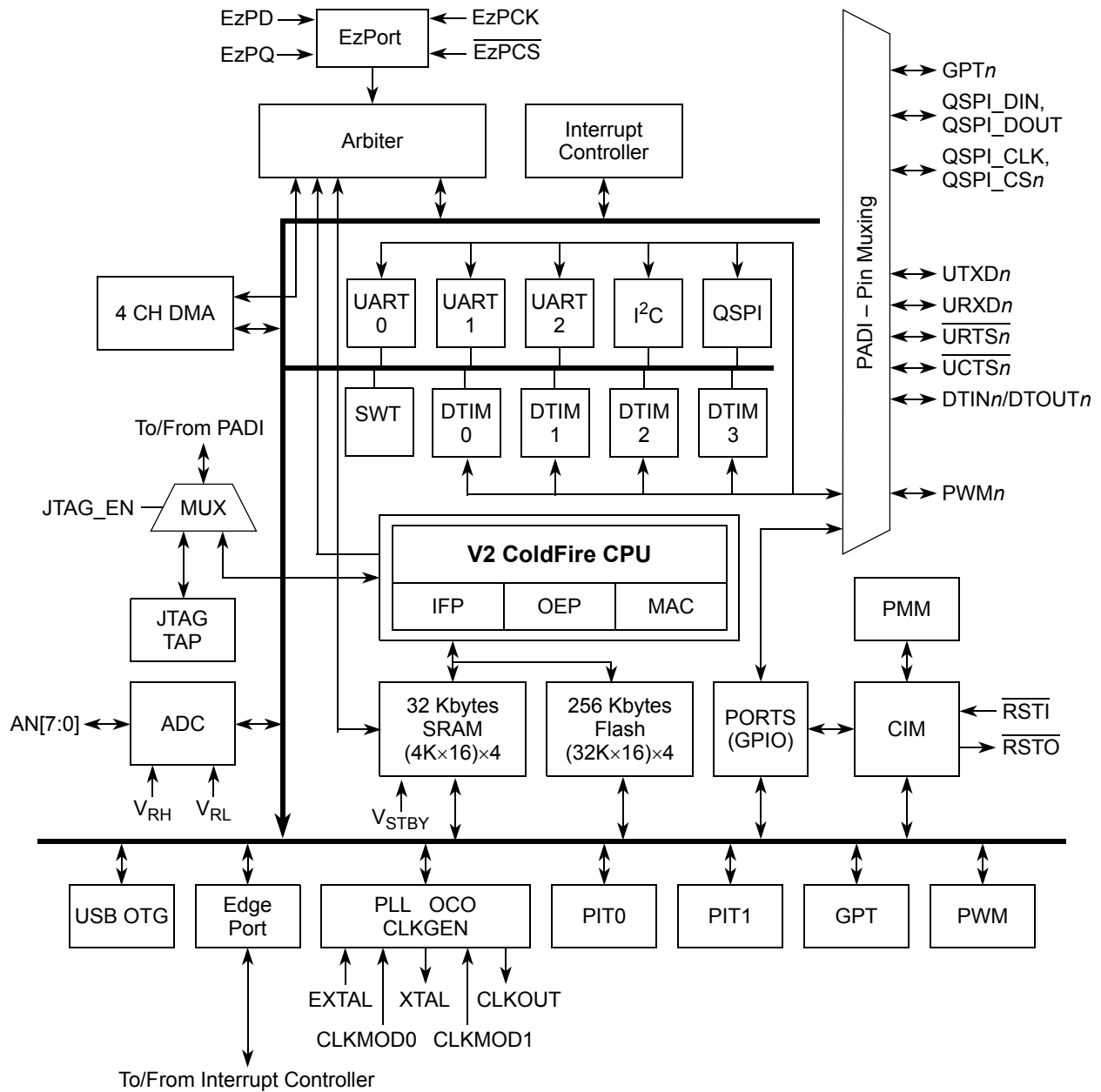

Figure 1. MCF52223 Block Diagram

1.2 Features

This document contains information on a new product under development. Freescale reserves the right to change or discontinue this product without notice. Specifications and information herein are subject to change without notice.

1.2.1 Feature Overview

The MCF52223 family includes the following features:

- Version 2 ColdFire variable-length RISC processor core
 - Static operation
 - 32-bit address and data paths on-chip
 - Up to 80 MHz processor core frequency
 - Sixteen general-purpose, 32-bit data and address registers
 - Implements ColdFire ISA_A with extensions to support the user stack pointer register and four new instructions for improved bit processing (ISA_A+)
 - Multiply-Accumulate (MAC) unit with 32-bit accumulator to support $16 \times 16 \rightarrow 32$ or $32 \times 32 \rightarrow 32$ operations
 - Illegal instruction decode that allows for 68-Kbyte emulation support
- System debug support
 - Real-time trace for determining dynamic execution path
 - Background debug mode (BDM) for in-circuit debugging (DEBUG_B+)
 - Real-time debug support, with six hardware breakpoints (4 PC, 1 address and 1 data) configurable into a 1- or 2-level trigger
- On-chip memories
 - 32-Kbyte dual-ported SRAM on CPU internal bus, supporting core and DMA access with standby power supply support
 - 256 Kbytes of interleaved flash memory supporting 2-1-1-1 accesses
- Power management
 - Fully static operation with processor sleep and whole chip stop modes
 - Rapid response to interrupts from the low-power sleep mode (wake-up feature)
 - Clock enable/disable for each peripheral when not used
 - Software controlled disable of external clock output for low-power consumption
- Universal Serial Bus On-The-Go (USB OTG) dual-mode host and device controller
 - Full-speed / low-speed host controller
 - USB 1.1 and 2.0 compliant full-speed / low speed device controller
 - 16 bidirectional end points
 - DMA or FIFO data stream interfaces
 - Low power consumption
 - OTG protocol logic
- Three universal asynchronous/synchronous receiver transmitters (UARTs)
 - 16-bit divider for clock generation
 - Interrupt control logic with maskable interrupts
 - DMA support
 - Data formats can be 5, 6, 7 or 8 bits with even, odd, or no parity
 - Up to two stop bits in 1/16 increments
 - Error-detection capabilities
 - Modem support includes request-to-send (RTS) and clear-to-send (CTS) lines for two UARTs
 - Transmit and receive FIFO buffers
- I²C module
 - Interchip bus interface for EEPROMs, LCD controllers, A/D converters, and keypads
 - Fully compatible with industry-standard I²C bus
 - Master and slave modes support multiple masters

MCF52223 Family Configurations

- Automatic interrupt generation with programmable level
- Queued serial peripheral interface (QSPI)
 - Full-duplex, three-wire synchronous transfers
 - Up to four chip selects available
 - Master mode operation only
 - Programmable bit rates up to half the CPU clock frequency
 - Up to 16 pre-programmed transfers
- Fast analog-to-digital converter (ADC)
 - Eight analog input channels
 - 12-bit resolution
 - Minimum 1.125 μ s conversion time
 - Simultaneous sampling of two channels for motor control applications
 - Single-scan or continuous operation
 - Optional interrupts on conversion complete, zero crossing (sign change), or under/over low/high limit
 - Unused analog channels can be used as digital I/O
- Four 32-bit timers with DMA support
 - 12.5 ns resolution at 80 MHz
 - Programmable sources for clock input, including an external clock option
 - Programmable prescaler
 - Input capture capability with programmable trigger edge on input pin
 - Output compare with programmable mode for the output pin
 - Free run and restart modes
 - Maskable interrupts on input capture or output compare
 - DMA trigger capability on input capture or output compare
- Four-channel general purpose timer
 - 16-bit architecture
 - Programmable prescaler
 - Output pulse-widths variable from microseconds to seconds
 - Single 16-bit input pulse accumulator
 - Toggle-on-overflow feature for pulse-width modulator (PWM) generation
 - One dual-mode pulse accumulation channel
- Pulse-width modulation timer
 - Operates as eight channels with 8-bit resolution or four channels with 16-bit resolution
 - Programmable period and duty cycle
 - Programmable enable/disable for each channel
 - Software selectable polarity for each channel
 - Period and duty cycle are double buffered. Change takes effect when the end of the current period is reached (PWM counter reaches zero) or when the channel is disabled.
 - Programmable center or left aligned outputs on individual channels
 - Four clock sources (A, B, SA, and SB) provide for a wide range of frequencies
 - Emergency shutdown
- Two periodic interrupt timers (PITs)
 - 16-bit counter
 - Selectable as free running or count down
- Real-Time Clock (RTC)

- Maintains system time-of-day clock
- Provides stopwatch and alarm interrupt functions
- Software watchdog timer
 - 32-bit counter
 - Low-power mode support
- Clock generation features
 - One to 48 MHz crystal, 8 MHz on-chip relaxation oscillator, or external oscillator reference options
 - Trimmed relaxation oscillator
 - Two to 10 MHz reference frequency for normal PLL mode with a pre-divider programmable from 1 to 8
 - System can be clocked from PLL or directly from crystal oscillator or relaxation oscillator
 - Low power modes supported
 - 2^n ($n \leq 0 \leq 15$) low-power divider for extremely low frequency operation
- Interrupt controller
 - Uniquely programmable vectors for all interrupt sources
 - Fully programmable level and priority for all peripheral interrupt sources
 - Seven external interrupt signals with fixed level and priority
 - Unique vector number for each interrupt source
 - Ability to mask any individual interrupt source or all interrupt sources (global mask-all)
 - Support for hardware and software interrupt acknowledge (IACK) cycles
 - Combinatorial path to provide wake-up from low-power modes
- DMA controller
 - Four fully programmable channels
 - Dual-address transfer support with 8-, 16-, and 32-bit data capability, along with support for 16-byte (4×32-bit) burst transfers
 - Source/destination address pointers that can increment or remain constant
 - 24-bit byte transfer counter per channel
 - Auto-alignment transfers supported for efficient block movement
 - Bursting and cycle steal support
 - Software-programmable DMA requesters for the UARTs (3) and 32-bit timers (4)
- Reset
 - Separate reset in and reset out signals
 - Seven sources of reset:
 - Power-on reset (POR)
 - External
 - Software
 - Watchdog
 - Loss of clock
 - Loss of lock
 - Low-voltage detection (LVD)
 - Status flag indication of source of last reset
- Chip integration module (CIM)
 - System configuration during reset
 - Selects one of six clock modes
 - Configures output pad drive strength
 - Unique part identification number and part revision number

- General purpose I/O interface
 - Up to 56 bits of general purpose I/O
 - Bit manipulation supported via set/clear functions
 - Programmable drive strengths
 - Unused peripheral pins may be used as extra GPIO
- JTAG support for system level board testing

1.2.2 V2 Core Overview

The version 2 ColdFire processor core is comprised of two separate pipelines decoupled by an instruction buffer. The two-stage instruction fetch pipeline (IFP) is responsible for instruction-address generation and instruction fetch. The instruction buffer is a first-in-first-out (FIFO) buffer that holds prefetched instructions awaiting execution in the operand execution pipeline (OEP). The OEP includes two pipeline stages. The first stage decodes instructions and selects operands (DSOC); the second stage (AGEX) performs instruction execution and calculates operand effective addresses, if needed.

The V2 core implements the ColdFire instruction set architecture revision A+ with added support for a separate user stack pointer register and four new instructions to assist in bit processing. Additionally, the MCF52223 core includes the multiply-accumulate (MAC) unit for improved signal processing capabilities. The MAC implements a three-stage arithmetic pipeline, optimized for 16×16 bit operations, with support for one 32-bit accumulator. Supported operands include 16- and 32-bit signed and unsigned integers, signed fractional operands, and a complete set of instructions to process these data types. The MAC provides support for execution of DSP operations within the context of a single processor at a minimal hardware cost.

1.2.3 Integrated Debug Module

The ColdFire processor core debug interface is provided to support system debugging with low-cost debug and emulator development tools. Through a standard debug interface, access to debug information and real-time tracing capability is provided on 100-lead packages. This allows the processor and system to be debugged at full speed without the need for costly in-circuit emulators.

The on-chip breakpoint resources include a total of nine programmable 32-bit registers: an address and an address mask register, a data and a data mask register, four PC registers, and one PC mask register. These registers can be accessed through the dedicated debug serial communication channel or from the processor's supervisor mode programming model. The breakpoint registers can be configured to generate triggers by combining the address, data, and PC conditions in a variety of single- or dual-level definitions. The trigger event can be programmed to generate a processor halt or initiate a debug interrupt exception. The MCF52223 implements revision B+ of the ColdFire Debug Architecture.

The MCF52223's interrupt servicing options during emulator mode allow real-time critical interrupt service routines to be serviced while processing a debug interrupt event. This ensures the system continues to operate even during debugging.

To support program trace, the V2 debug module provides processor status (PST[3:0]) and debug data (DDATA[3:0]) ports. These buses and the PSTCLK output provide execution status, captured operand data, and branch target addresses defining processor activity at the CPU's clock rate. The MCF52223 includes a new debug signal, ALLPST. This signal is the logical AND of the processor status (PST[3:0]) signals and is useful for detecting when the processor is in a halted state (PST[3:0] = 1111).

The full debug/trace interface is available only on the 100-pin packages. However, every product features the dedicated debug serial communication channel (DSI, DSO, DSCLK) and the ALLPST signal.

1.2.4 JTAG

The MCF52223 supports circuit board test strategies based on the Test Technology Committee of IEEE and the Joint Test Action Group (JTAG). The test logic includes a test access port (TAP) consisting of a 16-state controller, an instruction register, and three test registers (a 1-bit bypass register, a 112-bit boundary-scan register, and a 32-bit ID register). The boundary scan register

links the device's pins into one shift register. Test logic, implemented using static logic design, is independent of the device system logic.

The MCF52223 implementation can:

- Perform boundary-scan operations to test circuit board electrical continuity
- Sample MCF52223 system pins during operation and transparently shift out the result in the boundary scan register
- Bypass the MCF52223 for a given circuit board test by effectively reducing the boundary-scan register to a single bit
- Disable the output drive to pins during circuit-board testing
- Drive output pins to stable levels

1.2.5 On-Chip Memories

1.2.5.1 SRAM

The dual-ported SRAM module provides a general-purpose 32-Kbyte memory block that the ColdFire core can access in a single cycle. The location of the memory block can be set to any 32-Kbyte boundary within the 4-Gbyte address space. This memory is ideal for storing critical code or data structures and for use as the system stack. Because the SRAM module is physically connected to the processor's high-speed local bus, it can quickly service core-initiated accesses or memory-referencing commands from the debug module.

The SRAM module is also accessible by the DMA. The dual-ported nature of the SRAM makes it ideal for implementing applications with double-buffer schemes, where the processor and a DMA device operate in alternate regions of the SRAM to maximize system performance.

1.2.5.2 Flash Memory

The ColdFire flash module (CFM) is a non-volatile memory (NVM) module that connects to the processor's high-speed local bus. The CFM is constructed with four banks of 32-Kbyte \times 16-bit flash memory arrays to generate 256 Kbytes of 32-bit flash memory. These electrically erasable and programmable arrays serve as non-volatile program and data memory. The flash memory is ideal for program and data storage for single-chip applications, allowing for field reprogramming without requiring an external high voltage source. The CFM interfaces to the ColdFire core through an optimized read-only memory controller that supports interleaved accesses from the 2-cycle flash memory arrays. A backdoor mapping of the flash memory is used for all program, erase, and verify operations, as well as providing a read datapath for the DMA. Flash memory may also be programmed via the EzPort, which is a serial flash memory programming interface that allows the flash memory to be read, erased and programmed by an external controller in a format compatible with most SPI bus flash memory chips.

1.2.6 Power Management

The MCF52223 incorporates several low-power modes of operation entered under program control and exited by several external trigger events. An integrated power-on reset (POR) circuit monitors the input supply and forces an MCU reset as the supply voltage rises. The low voltage detector (LVD) monitors the supply voltage and is configurable to force a reset or interrupt condition if it falls below the LVD trip point. The RAM standby switch provides power to RAM when the supply voltage to the chip falls below the standby battery voltage.

1.2.7 USB On-The-Go Controller

The MCF52223 includes a Universal Serial Bus On-The-Go (USB OTG) dual-mode controller. USB is a popular standard for connecting peripherals and portable consumer electronic devices such as digital cameras and handheld computers to host PCs. The OTG supplement to the USB specification extends USB to peer-to-peer application, enabling devices to connect directly to each other without the need for a PC. The dual-mode controller on the MCF52223 can act as a USB OTG host and as a USB device. It also supports full-speed and low-speed modes.

1.2.8 UARTs

The MCF52223 has three full-duplex UARTs that function independently. The three UARTs can be clocked by the system bus clock, eliminating the need for an external clock source. On smaller packages, the third UART is multiplexed with other digital I/O functions.

1.2.9 I²C Bus

The I²C bus is a two-wire, bidirectional serial bus that provides a simple, efficient method of data exchange and minimizes the interconnection between devices. This bus is suitable for applications requiring occasional communications over a short distance between many devices.

1.2.10 QSPI

The queued serial peripheral interface (QSPI) provides a synchronous serial peripheral interface with queued transfer capability. It allows up to 16 transfers to be queued at once, minimizing the need for CPU intervention between transfers.

1.2.11 Fast ADC

The fast ADC consists of an eight-channel input select multiplexer and two independent sample and hold (S/H) circuits feeding separate 12-bit ADCs. The two separate converters store their results in accessible buffers for further processing.

The ADC can be configured to perform a single scan and halt, a scan when triggered, or a programmed scan sequence repeatedly until manually stopped.

The ADC can be configured for sequential or simultaneous conversion. When configured for sequential conversions, up to eight channels can be sampled and stored in any order specified by the channel list register. Both ADCs may be required during a scan, depending on the inputs to be sampled.

During a simultaneous conversion, both S/H circuits are used to capture two different channels at the same time. This configuration requires that a single channel may not be sampled by both S/H circuits simultaneously.

Optional interrupts can be generated at the end of the scan sequence if a channel is out of range (measures below the low threshold limit or above the high threshold limit set in the limit registers) or at several different zero crossing conditions.

1.2.12 DMA Timers (DTIM0–DTIM3)

There are four independent, DMA transfer capable 32-bit timers (DTIM0, DTIM1, DTIM2, and DTIM3) on the MCF52223. Each module incorporates a 32-bit timer with a separate register set for configuration and control. The timers can be configured to operate from the system clock or from an external clock source using one of the DTIN_{*n*} signals. If the system clock is selected, it can be divided by 16 or 1. The input clock is further divided by a user-programmable 8-bit prescaler that clocks the actual timer counter register (TCR_{*n*}). Each of these timers can be configured for input capture or reference (output) compare mode. Timer events may optionally cause interrupt requests or DMA transfers.

1.2.13 General Purpose Timer (GPT)

The general purpose timer (GPT) is a four-channel timer module consisting of a 16-bit programmable counter driven by a seven-stage programmable prescaler. Each of the four channels can be configured for input capture or output compare. Additionally, channel three, can be configured as a pulse accumulator.

A timer overflow function allows software to extend the timing capability of the system beyond the 16-bit range of the counter. The input capture and output compare functions allow simultaneous input waveform measurements and output waveform generation. The input capture function can capture the time of a selected transition edge. The output compare function can

generate output waveforms and timer software delays. The 16-bit pulse accumulator can operate as a simple event counter or a gated time accumulator.

1.2.14 Periodic Interrupt Timers (PIT0 and PIT1)

The two periodic interrupt timers (PIT0 and PIT1) are 16-bit timers that provide interrupts at regular intervals with minimal processor intervention. Each timer can count down from the value written in its PIT modulus register or it can be a free-running down-counter.

1.2.15 Real-Time Clock (RTC)

The Real-Time Clock (RTC) module maintains the system (time-of-day) clock and provides stopwatch, alarm, and interrupt functions. It includes full clock features: seconds, minutes, hours, days and supports a host of time-of-day interrupt functions along with an alarm interrupt.

1.2.16 Pulse-Width Modulation (PWM) Timers

The MCF52223 has an 8-channel, 8-bit PWM timer. Each channel has a programmable period and duty cycle as well as a dedicated counter. Each of the modulators can create independent continuous waveforms with software-selectable duty rates from 0% to 100%. The PWM outputs have programmable polarity, and can be programmed as left aligned outputs or center aligned outputs. For higher period and duty cycle resolution, each pair of adjacent channels ([7:6], [5:4], [3:2], and [1:0]) can be concatenated to form a single 16-bit channel. The module can, therefore, be configured to support 8/0, 6/1, 4/2, 2/3, or 0/4 8-/16-bit channels.

1.2.17 Software Watchdog Timer

The watchdog timer is a 32-bit timer that facilitates recovery from runaway code. The watchdog counter is a free-running down-counter that generates a reset on underflow. To prevent a reset, software must periodically restart the countdown.

1.2.18 Phase-Locked Loop (PLL)

The clock module contains a crystal oscillator, 8 MHz on-chip relaxation oscillator (OCO), phase-locked loop (PLL), reduced frequency divider (RFD), low-power divider status/control registers, and control logic. To improve noise immunity, the PLL, crystal oscillator, and relaxation oscillator have their own power supply inputs: VDDPLL and VSSPLL. All other circuits are powered by the normal supply pins, VDD and VSS.

1.2.19 Interrupt Controller (INTC)

The MCF52223 has a single interrupt controller that supports up to 63 interrupt sources. There are 56 programmable sources, 49 of which are assigned to unique peripheral interrupt requests. The remaining seven sources are unassigned and may be used for software interrupt requests.

1.2.20 DMA Controller

The direct memory access (DMA) controller provides an efficient way to move blocks of data with minimal processor intervention. It has four channels that allow byte, word, longword, or 16-byte burst line transfers. These transfers are triggered by software explicitly setting a $DCR_n[START]$ bit or by the occurrence of certain UART or DMA timer events.

1.2.21 Reset

The reset controller determines the source of reset, asserts the appropriate reset signals to the system, and keeps track of what caused the last reset. There are seven sources of reset:

- External reset input
- Power-on reset (POR)
- Watchdog timer
- Phase locked-loop (PLL) loss of lock
- PLL loss of clock
- Software
- Low-voltage detector (LVD)

Control of the LVD and its associated reset and interrupt are managed by the reset controller. Other registers provide status flags indicating the last source of reset and a control bit for software assertion of the \overline{RSTO} pin.

1.2.22 GPIO

Nearly all pins on the MCF52223 have general purpose I/O capability and are grouped into 8-bit ports. Some ports do not use all eight bits. Each port has registers that configure, monitor, and control the port pins.

1.2.23 Part Numbers and Packaging

This product is RoHS-compliant. Refer to the product page at freescale.com or contact your sales office for up-to-date RoHS information.

Part Number Summary

| Part Number | Flash / SRAM | Key Features | Package | Speed |
|-------------|------------------------|--|-----------------------|------------|
| MCF52221 | 128 Kbytes / 16 Kbytes | 3 UARTs, I ² C, QSPI, A/D, DMA, USBOTG, 16-/32-bit/PWM Timers | 64 LQFP 81 MAPBGA | 66, 80 MHz |
| MCF52223 | 256 Kbytes / 32 Kbytes | 3 UARTs, I ² C, QSPI, A/D, DMA, USBOTG, 16-/32-bit/PWM Timers | 81 MAPBGA 100 LQFP | 66, 80 MHz |

Figure 2 shows the pinout configuration for the 100 LQFP.

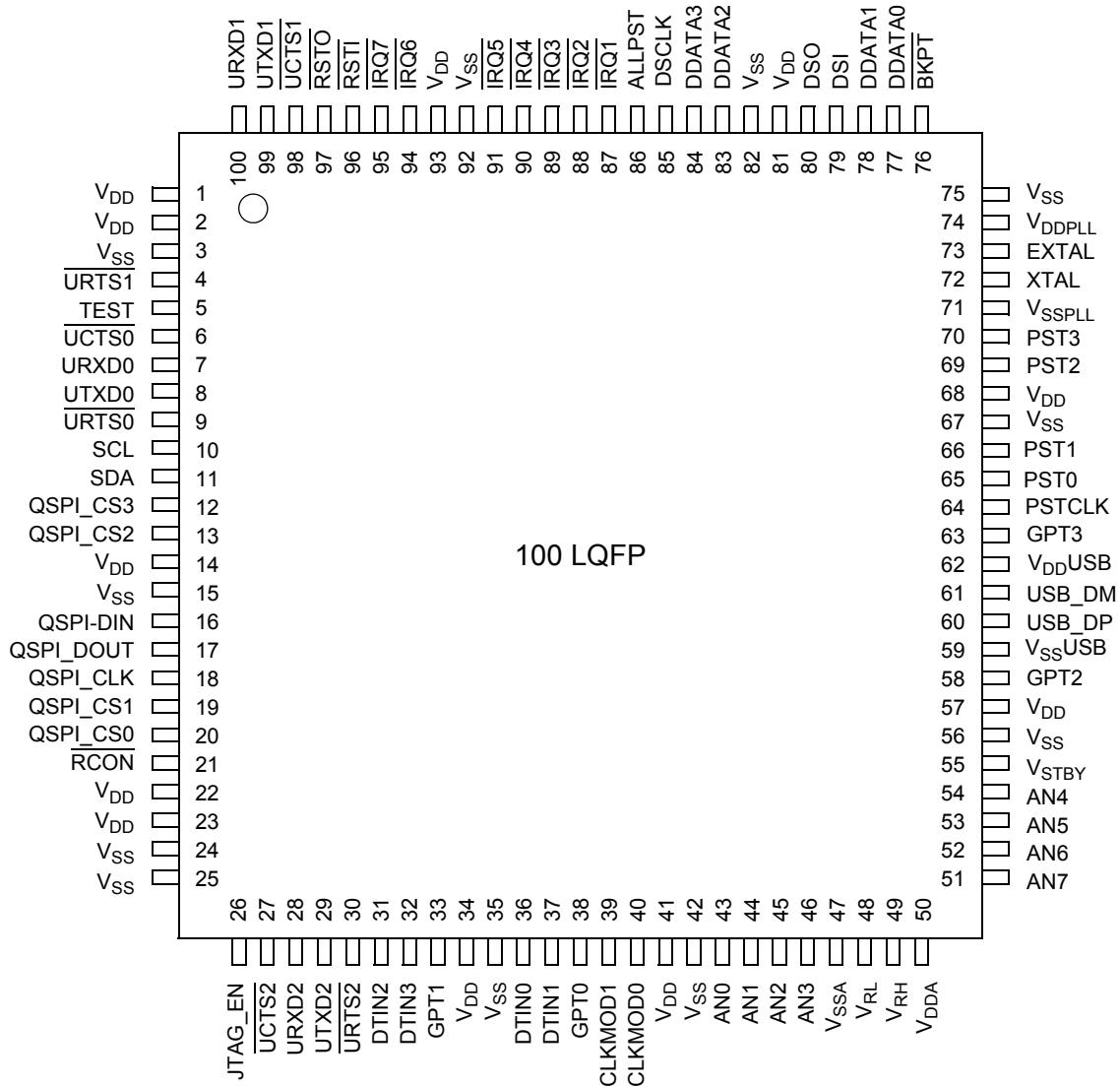

Figure 2. 100 LQFP Pin Assignments

MCF52223 Family Configurations

Figure 3 shows the pinout configuration for the 81 MAPBGA.

| | 1 | 2 | 3 | 4 | 5 | 6 | 7 | 8 | 9 |
|---|---------------------------|----------|---------------------------|--------------------------|--------------------------|--------------------------|---------------------|---------------------|------------------|
| A | V _{SS} | UTXD1 | $\overline{\text{RSTI}}$ | $\overline{\text{IRQ5}}$ | $\overline{\text{IRQ3}}$ | ALLPST | TDO | TMS | V _{SS} |
| B | $\overline{\text{URTS1}}$ | URXD1 | $\overline{\text{RSTO}}$ | $\overline{\text{IRQ6}}$ | $\overline{\text{IRQ2}}$ | $\overline{\text{TRST}}$ | TDI | V _{DD} PLL | EXTAL |
| C | $\overline{\text{UCTS0}}$ | TEST | $\overline{\text{UCTS1}}$ | $\overline{\text{IRQ7}}$ | $\overline{\text{IRQ4}}$ | $\overline{\text{IRQ1}}$ | TCLK | V _{SS} PLL | XTAL |
| D | URXD0 | UTXD0 | $\overline{\text{URTS0}}$ | V _{SS} | V _{DD} | V _{SS} | GPT3 | V _{DD} USB | USB_DM |
| E | SCL | SDA | V _{DD} | V _{DD} | V _{DD} | V _{DD} | V _{DD} | GPT2 | USB_DP |
| F | QSPI_CS3 | QSPI_CS2 | QSPI_DIN | V _{SS} | V _{DD} | V _{SS} | V _{SS} USB | V _{STBY} | AN4 |
| G | QSPI_DOUT | QSPI_CLK | $\overline{\text{RCON}}$ | DTIN1 | CLKMOD0 | AN2 | AN3 | AN5 | AN6 |
| H | QSPI_CS0 | QSPI_CS1 | DTIN3 | DTIN0 | CLKMOD1 | AN1 | V _{SSA} | V _{DDA} | AN7 |
| J | V _{SS} | JTAG_EN | DTIN2 | GPT1 | GPT0 | AN0 | V _{RL} | V _{RH} | V _{SSA} |

Figure 3. 81 MAPBGA Pin Assignments

Figure 4 shows the pinout configuration for the 64 LQFP and 64 QFN.

Figure 4. 64 LQFP and 64 QFN Pin Assignments

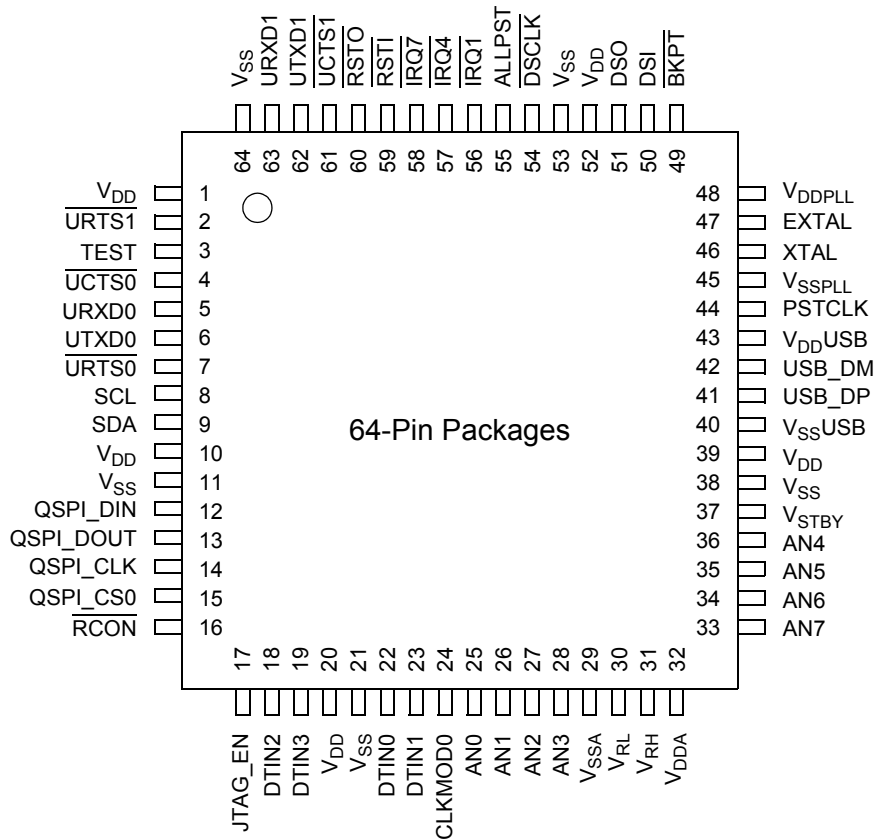

Table 2 shows the pin functions by primary and alternate purpose, and illustrates which packages contain each pin.

Table 2. Pin Functions by Primary and Alternate Purpose

| Pin Group | Primary Function | Secondary Function | Tertiary Function | Quaternary Function | Drive Strength / Control ¹ | Slew Rate / Control ¹ | Pull-up / Pull-down ² | Pin on 100 LQFP | Pin on 81 MAPBGA | Pin on 64 LQFP/QFN |
|------------------|--------------------|--------------------|-------------------|---------------------|---------------------------------------|----------------------------------|----------------------------------|-----------------|------------------|--------------------|
| ADC | AN7 | — | — | GPIO | Low | FAST | — | 51 | H9 | 33 |
| | AN6 | — | — | GPIO | Low | FAST | — | 52 | G9 | 34 |
| | AN5 | — | — | GPIO | Low | FAST | — | 53 | G8 | 35 |
| | AN4 | — | — | GPIO | Low | FAST | — | 54 | F9 | 36 |
| | AN3 | — | — | GPIO | Low | FAST | — | 46 | G7 | 28 |
| | AN2 | — | — | GPIO | Low | FAST | — | 45 | G6 | 27 |
| | AN1 | — | — | GPIO | Low | FAST | — | 44 | H6 | 26 |
| | AN0 | — | — | GPIO | Low | FAST | — | 43 | J6 | 25 |
| | SYNCA ³ | — | — | — | N/A | N/A | — | — | — | — |
| | SYNCB ³ | — | — | — | N/A | N/A | — | — | — | — |
| | VDDA | — | — | — | N/A | N/A | — | 50 | H8 | 32 |
| | VSSA | — | — | — | N/A | N/A | — | 47 | H7, J9 | 29 |
| | VRH | — | — | — | N/A | N/A | — | 49 | J8 | 31 |
| | VRL | — | — | — | N/A | N/A | — | 48 | J7 | 30 |
| Clock Generation | EXTAL | — | — | — | N/A | N/A | — | 73 | B9 | 47 |
| | XTAL | — | — | — | N/A | N/A | — | 72 | C9 | 46 |
| | VDDPLL | — | — | — | N/A | N/A | — | 74 | B8 | 48 |
| | VSSPLL | — | — | — | N/A | N/A | — | 71 | C8 | 45 |
| Debug Data | ALLPST | — | — | — | High | FAST | — | 86 | A6 | 55 |
| | DDATA[3:0] | — | — | GPIO | High | FAST | — | 84,83,78,77 | — | — |
| | PST[3:0] | — | — | GPIO | High | FAST | — | 70,69,66,65 | — | — |
| I ² C | SCL | USB_DMI | UTXD2 | GPIO | PDSR[0] | PSRR[0] | pull-up ⁴ | 10 | E1 | 8 |
| | SDA | USB_DPI | URXD2 | GPIO | PDSR[0] | PSRR[0] | pull-up ⁴ | 11 | E2 | 9 |

Table 2. Pin Functions by Primary and Alternate Purpose (continued)

| Pin Group | Primary Function | Secondary Function | Tertiary Function | Quaternary Function | Drive Strength / Control ¹ | Slew Rate / Control ¹ | Pull-up / Pull-down ² | Pin on 100 LQFP | Pin on 81 MAPBGA | Pin on 64 LQFP/QFN |
|-----------------------------|------------------------------------|--------------------|-------------------|---------------------|---------------------------------------|----------------------------------|----------------------------------|-----------------|------------------|--------------------|
| Interrupts | $\overline{\text{IRQ7}}$ | — | — | GPIO | Low | FAST | — | 95 | C4 | 58 |
| | $\overline{\text{IRQ6}}$ | — | USB_ID | GPIO | Low | FAST | — | 94 | B4 | — |
| | $\overline{\text{IRQ5}}$ | — | USB_VBUSV LD | GPIO | Low | FAST | — | 91 | A4 | — |
| | $\overline{\text{IRQ4}}$ | — | USB_PULLU P | GPIO | Low | FAST | — | 90 | C5 | 57 |
| | $\overline{\text{IRQ3}}$ | — | USB_SESSE ND | GPIO | Low | FAST | — | 89 | A5 | — |
| | $\overline{\text{IRQ2}}$ | — | USB_SESSV LD | GPIO | Low | FAST | — | 88 | B5 | — |
| | $\overline{\text{IRQ1}}$ | SYNCA | USB_ALT_CL K | GPIO | High | FAST | pull-up ⁴ | 87 | C6 | 56 |
| JTAG/BDM | JTAG_EN | — | — | — | N/A | N/A | pull-down | 26 | J2 | 17 |
| | TCLK/ PSTCLK | CLKOUT | — | — | High | FAST | pull-up ⁵ | 64 | C7 | 44 |
| | TDI/DSI | — | — | — | N/A | N/A | pull-up ⁵ | 79 | B7 | 50 |
| | TDO/DSO | — | — | — | High | FAST | — | 80 | A7 | 51 |
| | TMS /BKPT | — | — | — | N/A | N/A | pull-up ⁵ | 76 | A8 | 49 |
| | $\overline{\text{TRST}}$ /DSCLK | — | — | — | N/A | N/A | pull-up ⁵ | 85 | B6 | 54 |
| Mode Selection ⁶ | CLKMOD0 | — | — | — | N/A | N/A | pull-down ⁶ | 40 | G5 | 24 |
| | CLKMOD1 | — | — | — | N/A | N/A | pull-down ⁶ | 39 | H5 | — |
| | RCON/ EZPCS | — | — | — | N/A | N/A | pull-up | 21 | G3 | 16 |

Table 2. Pin Functions by Primary and Alternate Purpose (continued)

| Pin Group | Primary Function | Secondary Function | Tertiary Function | Quaternary Function | Drive Strength / Control ¹ | Slew Rate / Control ¹ | Pull-up / Pull-down ² | Pin on 100 LQFP | Pin on 81 MAPBGA | Pin on 64 LQFP/QFN |
|--------------------|--------------------------|--------------------|---------------------------|---------------------|---------------------------------------|----------------------------------|------------------------------------|-----------------|------------------|--------------------|
| QSPI | QSPI_DIN/ EZPD | — | URXD1 | GPIO | PDSR[2] | PSRR[2] | — | 16 | F3 | 12 |
| | QSPI_DOUT/ EZPQ | — | UTXD1 | GPIO | PDSR[1] | PSRR[1] | — | 17 | G1 | 13 |
| | QSPI_CLK/ EZPCK | SCL | $\overline{\text{URTS1}}$ | GPIO | PDSR[3] | PSRR[3] | pull-up ⁸ | 18 | G2 | 14 |
| | QSPI_CS3 | SYNCA | USB_DP_PD OWN | GPIO | PDSR[7] | PSRR[7] | pull-up/pull- down ⁷ | 12 | F1 | — |
| | QSPI_CS2 | — | USB_DM_PD OWN | GPIO | PDSR[6] | PSRR[6] | pull-up/pull- down ⁷ | 13 | F2 | — |
| | QSPI_CS1 | — | USB_PULLU P | GPIO | PDSR[5] | PSRR[5] | — | 19 | H2 | — |
| | QSPI_CS0 | SDA | $\overline{\text{UCTS1}}$ | GPIO | PDSR[4] | PSRR[4] | pull-up ⁸ | 20 | H1 | 15 |
| Reset ⁹ | $\overline{\text{RSTI}}$ | — | — | — | N/A | N/A | pull-up ⁹ | 96 | A3 | 59 |
| | $\overline{\text{RSTO}}$ | — | — | — | high | FAST | — | 97 | B3 | 60 |
| Test | TEST | — | — | — | N/A | N/A | pull-down | 5 | C2 | 3 |
| Timers, 16-bit | GPT3 | — | PWM7 | GPIO | PDSR[23] | PSRR[23] | pull-up ¹⁰ | 63 | | — |
| | GPT2 | — | PWM5 | GPIO | PDSR[22] | PSRR[22] | pull-up ¹⁰ | 58 | E8 | — |
| | GPT1 | — | PWM3 | GPIO | PDSR[21] | PSRR[21] | pull-up ¹⁰ | 33 | J4 | — |
| | GPT0 | — | PWM1 | GPIO | PDSR[20] | PSRR[20] | pull-up ¹⁰ | 38 | J5 | — |
| Timers, 32-bit | DTIN3 | DTOUT3 | PWM6 | GPIO | PDSR[19] | PSRR[19] | — | 32 | H3 | 19 |
| | DTIN2 | DTOUT2 | PWM4 | GPIO | PDSR[18] | PSRR[18] | — | 31 | J3 | 18 |
| | DTIN1 | DTOUT1 | PWM2 | GPIO | PDSR[17] | PSRR[17] | — | 37 | G4 | 23 |
| | DTIN0 | DTOUT0 | PWM0 | GPIO | PDSR[16] | PSRR[16] | — | 36 | H4 | 22 |

Table 2. Pin Functions by Primary and Alternate Purpose (continued)

| Pin Group | Primary Function | Secondary Function | Tertiary Function | Quaternary Function | Drive Strength / Control ¹ | Slew Rate / Control ¹ | Pull-up / Pull-down ² | Pin on 100 LQFP | Pin on 81 MAPBGA | Pin on 64 LQFP/QFN |
|-----------|---------------------------|--------------------|-----------------------------|---------------------|---------------------------------------|----------------------------------|----------------------------------|---------------------------------|----------------------|--------------------|
| UART 0 | $\overline{\text{UCTS0}}$ | — | USB_VBUSE | GPIO | PDSR[11] | PSRR[11] | — | 6 | C1 | 4 |
| | $\overline{\text{URTS0}}$ | — | USB_VBUSD | GPIO | PDSR[10] | PSRR[10] | — | 9 | D3 | 7 |
| | URXD0 | — | USB_RCV | GPIO | PDSR[9] | PSRR[9] | — | 7 | D1 | 5 |
| | UTXD0 | — | USB_SUSPEND | GPIO | PDSR[8] | PSRR[8] | — | 8 | D2 | 6 |
| UART 1 | $\overline{\text{UCTS1}}$ | SYNCA | URXD2 | GPIO | PDSR[15] | PSRR[15] | — | 98 | C3 | 61 |
| | $\overline{\text{URTS1}}$ | SYNCB | UTXD2 | GPIO | PDSR[14] | PSRR[14] | — | 4 | B1 | 2 |
| | URXD1 | — | $\overline{\text{USB_OE}}$ | GPIO | PDSR[13] | PSRR[13] | — | 100 | B2 | 63 |
| | UTXD1 | — | USB_SPEED | GPIO | PDSR[12] | PSRR[12] | — | 99 | A2 | 62 |
| UART 2 | $\overline{\text{UCTS2}}$ | — | USB_VBUSCHG | GPIO | PDSR[27] | PSRR[27] | — | 27 | — | — |
| | $\overline{\text{URTS2}}$ | — | USB_VBUSDIS | GPIO | PDSR[26] | PSRR[26] | — | 30 | — | — |
| | URXD2 | — | USB_DATA | GPIO | PDSR[25] | PSRR[25] | — | 28 | — | — |
| | UTXD2 | — | USB_SE0 | GPIO | PDSR[24] | PSRR[24] | — | 29 | — | — |
| VSTBY | VSTBY | — | — | — | N/A | N/A | — | 55 | F8 | 37 |
| USB | VDDUSB | — | — | — | N/A | N/A | — | 62 | D8 | 43 |
| | VSSUSB | — | — | — | N/A | N/A | — | 59 | F7 | 40 |
| | USB_DM | — | — | — | N/A | N/A | — | 61 | D9 | 42 |
| | USB_DP | — | — | — | N/A | N/A | — | 60 | E9 | 41 |
| VDD | VDD | — | — | — | N/A | N/A | — | 1,2,14,22,23,34,41,57,68,81,93 | D5,E3–E7,F5 | 1,10,20,39,52 |
| VSS | VSS | — | — | — | N/A | N/A | — | 3,15,24,25,35,42,56,67,75,82,92 | A1,A9,D4,D6,F4,F6,J1 | 11,21,38,53,64 |

¹ The PDSR and PSSR registers are described in the General Purpose I/O chapter. All programmable signals default to 2 mA drive and FAST slew rate in normal (single-chip) mode.

² All signals have a pull-up in GPIO mode.

- ³ These signals are multiplexed on other pins.
- ⁴ For primary and GPIO functions only.
- ⁵ Only when JTAG mode is enabled.
- ⁶ CLKMOD0 and CLKMOD1 have internal pull-down resistors; however, the use of external resistors is very strongly recommended.
- ⁷ When these pins are configured for USB signals, they should use the USB transceiver's internal pull-up/pull-down resistors (see the description of the OTG_CTRL register). If these pins are not configured for USB signals, each pin should be pulled down externally using a 10 k Ω resistor.
- ⁸ For secondary and GPIO functions only.
- ⁹ $\overline{\text{RSTI}}$ has an internal pull-up resistor; however, the use of an external resistor is very strongly recommended.
- ¹⁰ For GPIO function. Primary Function has pull-up control within the GPT module.

1.3 Reset Signals

Table 3 describes signals used to reset the chip or as a reset indication.

Table 3. Reset Signals

| Signal Name | Abbreviation | Function | I/O |
|-------------|--------------------------|---|-----|
| Reset In | $\overline{\text{RSTI}}$ | Primary reset input to the device. Asserting $\overline{\text{RSTI}}$ for at least 8 CPU clock cycles immediately resets the CPU and peripherals. | I |
| Reset Out | $\overline{\text{RSTO}}$ | Driven low for 1024 CPU clocks after the reset source has deasserted. | O |

1.4 PLL and Clock Signals

Table 4 describes signals used to support the on-chip clock generation circuitry.

Table 4. PLL and Clock Signals

| Signal Name | Abbreviation | Function | I/O |
|-------------------|--------------|--|-----|
| External Clock In | EXTAL | Crystal oscillator or external clock input except when the on-chip relaxation oscillator is used. | I |
| Crystal | XTAL | Crystal oscillator output except when CLKMOD1=1, then sampled as part of the clock mode selection mechanism. | O |
| Clock Out | CLKOUT | This output signal reflects the internal system clock. | O |

1.5 Mode Selection

Table 5 describes signals used in mode selection; Table 6 describes the particular clocking modes.

Table 5. Mode Selection Signals

| Signal Name | Abbreviation | Function | I/O |
|----------------------|--------------|---|-----|
| Clock Mode Selection | CLKMOD[1:0] | Selects the clock boot mode. | I |
| Reset Configuration | RCON | The Serial Flash Programming mode is entered by asserting the RCON pin (with the TEST pin negated) as the chip comes out of reset. During this mode, the EzPort has access to the flash memory which can be programmed from an external device. | |
| Test | TEST | Reserved for factory testing only and in normal modes of operation should be connected to VSS to prevent unintentional activation of test functions. | I |

Table 6. Clocking Modes

| CLKMOD[1:0] | XTAL | Configure the clock mode. |
|-------------|------|---|
| 00 | 0 | PLL disabled, clock driven by external oscillator |
| 00 | 1 | PLL disabled, clock driven by on-chip oscillator |
| 01 | N/A | PLL disabled, clock driven by crystal |
| 10 | 0 | PLL in normal mode, clock driven by external oscillator |
| 10 | 1 | PLL in normal mode, clock driven by on-chip oscillator |
| 11 | N/A | PLL in normal mode, clock driven by crystal |

1.6 External Interrupt Signals

Table 7 describes the external interrupt signals.

Table 7. External Interrupt Signals

| Signal Name | Abbreviation | Function | I/O |
|---------------------|------------------------------|-----------------------------|-----|
| External Interrupts | $\overline{\text{IRQ}}[7:1]$ | External interrupt sources. | I |

1.7 Queued Serial Peripheral Interface (QSPI)

Table 8 describes the QSPI signals.

Table 8. Queued Serial Peripheral Interface (QSPI) Signals

| Signal Name | Abbreviation | Function | I/O |
|-------------------------------------|--------------|--|-----|
| QSPI Synchronous Serial Output | QSPI_DOUT | Provides the serial data from the QSPI and can be programmed to be driven on the rising or falling edge of QSPI_CLK. | O |
| QSPI Synchronous Serial Data Input | QSPI_DIN | Provides the serial data to the QSPI and can be programmed to be sampled on the rising or falling edge of QSPI_CLK. | I |
| QSPI Serial Clock | QSPI_CLK | Provides the serial clock from the QSPI. The polarity and phase of QSPI_CLK are programmable. | O |
| Synchronous Peripheral Chip Selects | QSPI_CS[3:0] | QSPI peripheral chip select; can be programmed to be active high or low. | O |

1.8 USB On-the-Go

This device is compliant with industry standard USB 2.0 specification.

1.9 I²C I/O Signals

Table 9 describes the I²C serial interface module signals.

Table 9. I²C I/O Signals

| Signal Name | Abbreviation | Function | I/O |
|--------------|--------------|---|-----|
| Serial Clock | SCL | Open-drain clock signal for the for the I ² C interface. When the bus is in master mode, this clock is driven by the I ² C module; when the bus is in slave mode, this clock becomes the clock input. | I/O |
| Serial Data | SDA | Open-drain signal that serves as the data input/output for the I ² C interface. | I/O |

1.10 UART Module Signals

Table 10 describes the UART module signals.

Table 10. UART Module Signals

| Signal Name | Abbreviation | Function | I/O |
|-----------------------------|----------------------------|---|-----|
| Transmit Serial Data Output | UTXD _n | Transmitter serial data outputs for the UART modules. The output is held high (mark condition) when the transmitter is disabled, idle, or in the local loopback mode. Data is shifted out, LSB first, on this pin at the falling edge of the serial clock source. | O |
| Receive Serial Data Input | URXD _n | Receiver serial data inputs for the UART modules. Data is received on this pin LSB first. When the UART clock is stopped for power-down mode, any transition on this pin restarts the clock. | I |
| Clear-to-Send | $\overline{\text{UCTS}}_n$ | Indication to the UART modules that they can begin data transmission. | I |
| Request-to-Send | $\overline{\text{URTS}}_n$ | Automatic request-to-send outputs from the UART modules. This signal can also be configured to be asserted and negated as a function of the Rx FIFO level. | O |

1.11 DMA Timer Signals

Table 11 describes the signals of the four DMA timer modules.

Table 11. DMA Timer Signals

| Signal Name | Abbreviation | Function | I/O |
|------------------|--------------|---|-----|
| DMA Timer Input | DTIN | Event input to the DMA timer modules. | I |
| DMA Timer Output | DTOUT | Programmable output from the DMA timer modules. | O |

1.12 ADC Signals

Table 12 describes the signals of the Analog-to-Digital Converter.

Table 12. ADC Signals

| Signal Name | Abbreviation | Function | I/O |
|------------------|------------------|---|-----|
| Analog Inputs | AN[7:0] | Inputs to the analog-to-digital converter. | I |
| Analog Reference | V _{RH} | Reference voltage high and low inputs. | I |
| | V _{RL} | | I |
| Analog Supply | V _{DDA} | Isolate the ADC circuitry from power supply noise. | — |
| | V _{SSA} | | — |
| ADC Sync Inputs | SYNCA / SYNCB | These signals can initiate an analog-to-digital conversion process. | I |

1.13 General Purpose Timer Signals

Table 13 describes the general purpose timer signals.

Table 13. GPT Signals

| Signal Name | Abbreviation | Function | I/O |
|------------------------------------|--------------|---|-----|
| General Purpose Timer Input/Output | GPT[3:0] | Inputs to or outputs from the general purpose timer module. | I/O |

1.14 Pulse Width Modulator Signals

Table 14 describes the PWM signals.

Table 14. PWM Signals

| Signal Name | Abbreviation | Function | I/O |
|---------------------|--------------|--|-----|
| PWM Output Channels | PWM[7:0] | Pulse width modulated output for PWM channels. | O |

1.15 Debug Support Signals

These signals are used as the interface to the on-chip JTAG controller and the BDM logic.

Table 15. Debug Support Signals

| Signal Name | Abbreviation | Function | I/O |
|--------------------------|--------------------------|---|-----|
| JTAG Enable | JTAG_EN | Select between debug module and JTAG signals at reset. | I |
| Test Reset | $\overline{\text{TRST}}$ | This active-low signal is used to initialize the JTAG logic asynchronously. | I |
| Test Clock | TCLK | Used to synchronize the JTAG logic. | I |
| Test Mode Select | TMS | Used to sequence the JTAG state machine. TMS is sampled on the rising edge of TCLK. | I |
| Test Data Input | TDI | Serial input for test instructions and data. TDI is sampled on the rising edge of TCLK. | I |
| Test Data Output | TDO | Serial output for test instructions and data. TDO is tri-stateable and is actively driven in the shift-IR and shift-DR controller states. TDO changes on the falling edge of TCLK. | O |
| Development Serial Clock | DSCLK | Development Serial Clock - Internally synchronized input. (The logic level on DSCLK is validated if it has the same value on two consecutive rising bus clock edges.) Clocks the serial communication port to the debug module during packet transfers. Maximum frequency is PSTCLK/5. At the synchronized rising edge of DSCLK, the data input on DSI is sampled and DSO changes state. | I |
| Breakpoint | $\overline{\text{BKPT}}$ | Breakpoint - Input used to request a manual breakpoint. Assertion of $\overline{\text{BKPT}}$ puts the processor into a halted state after the current instruction completes. Halt status is reflected on processor status/debug data signals (PST[3:0] and PSTDDATA[7:0]) as the value 0xF. If CSR[BKD] is set (disabling normal $\overline{\text{BKPT}}$ functionality), asserting $\overline{\text{BKPT}}$ generates a debug interrupt exception in the processor. | I |

Table 15. Debug Support Signals (continued)

| Signal Name | Abbreviation | Function | I/O |
|------------------------------|--------------|---|-----|
| Development Serial Input | DSI | Development Serial Input - Internally synchronized input that provides data input for the serial communication port to the debug module, after the DSCLK has been seen as high (logic 1). | I |
| Development Serial Output | DSO | Development Serial Output - Provides serial output communication for debug module responses. DSO is registered internally. The output is delayed from the validation of DSCLK high. | O |
| Debug Data | DDATA[3:0] | Display captured processor data and breakpoint status. The CLKOUT signal can be used by the development system to know when to sample DDATA[3:0]. | O |
| Processor Status Clock | PSTCLK | Processor Status Clock - Delayed version of the processor clock. Its rising edge appears in the center of valid PST and DDATA output. PSTCLK indicates when the development system should sample PST and DDATA values. If real-time trace is not used, setting CSR[PCD] keeps PSTCLK, and PST and DDATA outputs from toggling without disabling triggers. Non-quiescent operation can be reenabled by clearing CSR[PCD], although the external development systems must resynchronize with the PST and DDATA outputs. PSTCLK starts clocking only when the first non-zero PST value (0xC, 0xD, or 0xF) occurs during system reset exception processing. | O |
| Processor Status Outputs | PST[3:0] | Indicate core status. Debug mode timing is synchronous with the processor clock; status is unrelated to the current bus transfer. The CLKOUT signal can be used by the development system to know when to sample PST[3:0]. | O |
| All Processor Status Outputs | ALLPST | Logical AND of PST[3:0]. The CLKOUT signal can be used by the development system to know when to sample ALLPST. | O |

1.16 EzPort Signal Descriptions

Table contains a list of EzPort external signals.

Table 16. EzPort Signal Descriptions

| Signal Name | Abbreviation | Function | I/O |
|------------------------|--------------|---|-----|
| EzPort Clock | EZPCK | Shift clock for EzPort transfers. | I |
| EzPort Chip Select | EZPCS | Chip select for signalling the start and end of serial transfers. | I |
| EzPort Serial Data In | EZPD | EZPD is sampled on the rising edge of EZPCK. | I |
| EzPort Serial Data Out | EZPQ | EZPQ transitions on the falling edge of EZPCK. | O |

1.17 Power and Ground Pins

The pins described in Table 17 provide system power and ground to the chip. Multiple pins are provided for adequate current capability. All power supply pins must have adequate bypass capacitance for high-frequency noise suppression.

Table 17. Power and Ground Pins

| Signal Name | Abbreviation | Function |
|-------------------|---------------------|---|
| PLL Analog Supply | VDDPLL, VSSPLL | Dedicated power supply signals to isolate the sensitive PLL analog circuitry from the normal levels of noise present on the digital power supply. |
| USB Power Supply | V _{DD} USB | This pin supplies power to the USB Module. |
| USB Ground Supply | V _{SS} USB | This pin is the negative (ground) supply pin for the USB Module. |
| Positive Supply | VDD | These pins supply positive power to the core logic. |
| Ground | VSS | This pin is the negative supply (ground) to the chip. |

2 Electrical Characteristics

This section contains electrical specification tables and reference timing diagrams for the MCF52223 microcontroller unit, including detailed information on power considerations, DC/AC electrical characteristics, and AC timing specifications.

NOTE

The parameters specified in this data sheet supersede any values found in the module specifications.

2.1 Maximum Ratings

Table 18. Absolute Maximum Ratings^{1, 2}

| Rating | Symbol | Value | Unit |
|---|--------------------------|--------------|------|
| Supply voltage | V_{DD} | -0.3 to +4.0 | V |
| Clock synthesizer supply voltage | V_{DDPLL} | -0.3 to +4.0 | V |
| RAM standby supply voltage | V_{STBY} | -0.3 to +4.0 | V |
| USB standby supply voltage | V_{DDUSB} | -0.3 to +4.0 | V |
| Digital input voltage ³ | V_{IN} | -0.3 to +4.0 | V |
| EXTAL pin voltage | V_{EXTAL} | 0 to 3.3 | V |
| XTAL pin voltage | V_{XTAL} | 0 to 3.3 | V |
| Instantaneous maximum current Single pin limit (applies to all pins) ^{4, 5} | I_{DD} | 25 | mA |
| Operating temperature range (packaged) | T_A ($T_L - T_H$) | -40 to 85 | °C |
| Storage temperature range | T_{stg} | -65 to 150 | °C |

¹ Functional operating conditions are given in DC Electrical Specifications. Absolute Maximum Ratings are stress ratings only, and functional operation at the maxima is not guaranteed. Stress beyond those listed may affect device reliability or cause permanent damage to the device.

² This device contains circuitry protecting against damage due to high static voltage or electrical fields; however, it is advised that normal precautions be taken to avoid application of any voltages higher than maximum-rated voltages to this high-impedance circuit. Reliability of operation is enhanced if unused inputs are tied to an appropriate logic voltage level (V_{SS} or V_{DD}).

³ Input must be current limited to the I_{DD} value specified. To determine the value of the required current-limiting resistor, calculate resistance values for positive and negative clamp voltages, then use the larger of the two values.

⁴ All functional non-supply pins are internally clamped to V_{SS} and V_{DD} .

⁵ The power supply must maintain regulation within operating V_{DD} range during instantaneous and operating maximum current conditions. If positive injection current ($V_{in} > V_{DD}$) is greater than I_{DD} , the injection current may flow out of V_{DD} and could result in the external power supply going out of regulation. Ensure that the external V_{DD} load shunts current greater than maximum injection current. This is the greatest risk when the MCU is not consuming power (e.g., no clock).

2.2 Current Consumption

Table 19, Table 20, and Figure 5 show the typical current consumption in low-power modes.

Table 19. Current Consumption in Low-Power Mode, Code From Flash Memory^{1,2,3}

| Mode | 8 MHz (Typ) | 16 MHz (Typ) | 64 MHz (Typ) | 80 MHz (Typ) | Units |
|--------------------------------------|-------------|--------------|--------------|--------------|-------|
| Stop mode 3 (Stop 11) ⁴ | 0.070 | | | | mA |
| Stop mode 2 (Stop 10) ⁴ | 2.9 | | | | |
| Stop mode 1 (Stop 01) ^{4,5} | 3.6 | 3.9 | 6 | 6.7 | |
| Stop mode 0 (Stop 00) ⁵ | 3.6 | 3.9 | 6 | 6.7 | |
| Wait / Doze | 13 | 23 | 38 | 44 | |
| Run | TBD | TBD | TBD | TBD | |

¹ All values are measured with a 3.30V power supply. Tests performed at room temperature.

² Refer to the Power Management chapter in the *MCF52223 Reference Manual* for more information on low-power modes.

³ CLKOUT, PST/DDATA signals, and all peripheral clocks except UART0 and CFM off before entering low-power mode. CLKOUT is disabled.

⁴ See the description of the Low-Power Control Register (LPCR) in the *MCF52223 Reference Manual* for more information on stop modes 0–3.

⁵ Results are identical to STOP 00 for typical values because they only differ by CLKOUT power consumption. CLKOUT is already disabled in this instance prior to entering low-power mode.

Table 20. Current Consumption in Low-Power Mode, Code From SRAM^{1,2,3}

| Mode | 8 MHz (Typ) | 16 MHz (Typ) | 64 MHz (Typ) | 80 MHz (Typ) | Units |
|--------------------------------------|-------------|--------------|--------------|--------------|-------|
| Stop mode 3 (Stop 11) ⁴ | 0.010 | | | | mA |
| Stop mode 2 (Stop 10) ⁴ | 2.7 | | | | |
| Stop mode 1 (Stop 01) ^{4,5} | 3.4 | 3.7 | 5.8 | 6.5 | |
| Stop mode 0 (Stop 00) ⁵ | 3.4 | 3.7 | 5.8 | 6.5 | |
| Wait / Doze | 6 | 8 | 22 | 27 | |
| Run | 7 | 11 | 33 | 41 | |

¹ All values are measured with a 3.30V power supply. Tests performed at room temperature.

² Refer to the Power Management chapter in the *MCF52223 Reference Manual* for more information on low-power modes.

³ CLKOUT, PST/DDATA signals, and all peripheral clocks except UART0 off before entering low-power mode. CLKOUT is disabled. Code executed from SRAM with flash memory shut off by writing 0x0 to the FLASHBAR register.

⁴ See the description of the Low-Power Control Register (LPCR) in the *MCF52223 Reference Manual* for more information on stop modes 0–3.

⁵ Results are identical to STOP 00 for typical values because they only differ by CLKOUT power consumption. CLKOUT is already disabled in this instance prior to entering low-power mode.

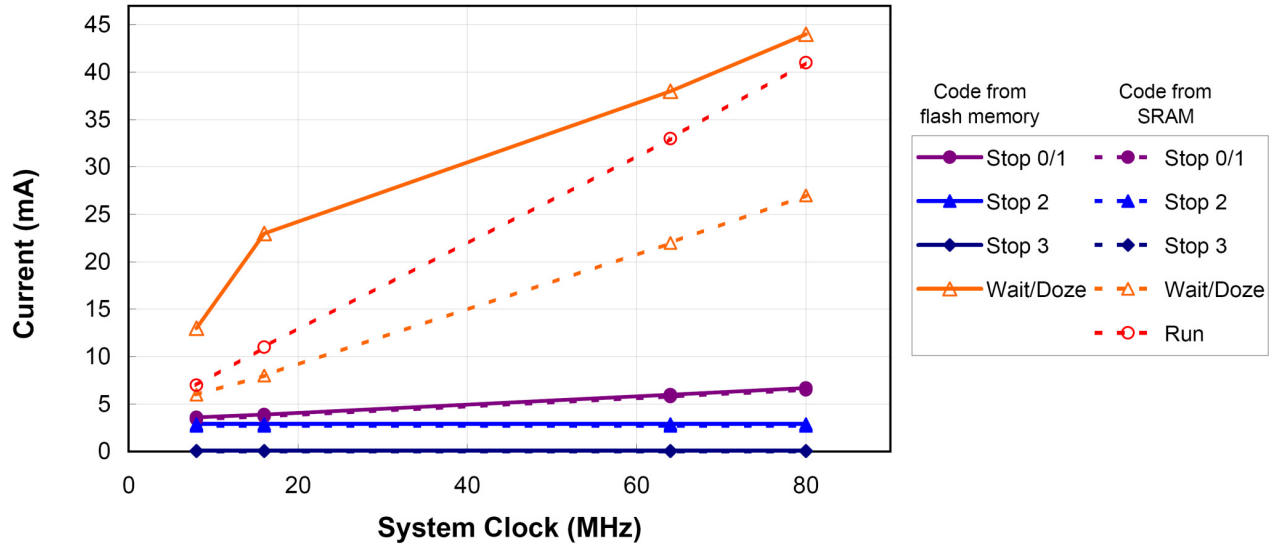

Figure 5. Plot of Current Consumption in Low-Power Modes

Table 21. Typical Active Current Consumption Specifications

| Characteristic | Symbol | Typical ¹ Active (SRAM) | Typical ¹ Active (Flash) | Peak ² Active (Flash) | Unit |
|---|--------------------|--|---|--|------|
| 8 MHz core & I/O | I _{DD} | 8 | 11 | 18 | mA |
| 16 MHz core & I/O | | 11 | 19 | 33 | |
| 64 MHz core & I/O | | 35 | 44 | 82 | |
| 80 MHz core & I/O | | 43 | 52 | 98 | |
| RAM standby supply current • Normal operation: V _{DD} > V _{STBY} - 0.3 V • Transient condition: V _{STBY} - 0.3 V > V _{DD} > V _{SS} + 0.5 V • Standby operation: V _{DD} < V _{SS} + 0.5 V | I _{STBY} | — | — | 0.4 TBD 16 | μA |
| Analog supply current • Normal operation • Standby mode • Powered down | I _{DDA} | 2 ^(see note 3) | | 13 TBD 0 | mA |
| USB supply current | I _{DDUSB} | — | — | 2 | |
| PLL supply current | I _{DDPLL} | — | — | 6 ^(see note 4) | mA |

- ¹ Tested at room temperature with CPU polling a status register. All clocks were off except the UART and CFM (when running from flash memory).
- ² Peak current measured with all modules active, CPU polling a status register, and default drive strength with matching load.
- ³ Tested using Auto Power Down (APD), which powers down the ADC between conversions; ADC running at 4 MHz in Once Parallel mode with a sample rate of 3 kHz.
- ⁴ Tested with the PLL MFD set to 7 (max value). Setting the MFD to a lower value results in lower current consumption.

2.3 Thermal Characteristics

Table 22 lists thermal resistance values.

Table 22. Thermal Characteristics

| | Characteristic | | Symbol | Value | Unit |
|-----------|---|-------------------------|----------------|-------------------|------|
| 100 LQFP | Junction to ambient, natural convection | Single layer board (1s) | θ_{JA} | 53 ^{1,2} | °C/W |
| | Junction to ambient, natural convection | Four layer board (2s2p) | θ_{JA} | 39 ^{1,3} | °C/W |
| | Junction to ambient, (@200 ft/min) | Single layer board (1s) | θ_{JMA} | 42 ^{1,3} | °C/W |
| | Junction to ambient, (@200 ft/min) | Four layer board (2s2p) | θ_{JMA} | 33 ^{1,3} | °C/W |
| | Junction to board | — | θ_{JB} | 25 ⁴ | °C/W |
| | Junction to case | — | θ_{JC} | 9 ⁵ | °C/W |
| | Junction to top of package | Natural convection | Ψ_{jt} | 2 ⁶ | °C/W |
| | Maximum operating junction temperature | — | T_j | 105 | °C |
| 81 MAPBGA | Junction to ambient, natural convection | Single layer board (1s) | θ_{JA} | 61 ^{1,2} | °C/W |
| | Junction to ambient, natural convection | Four layer board (2s2p) | θ_{JA} | 35 ^{2,3} | °C/W |
| | Junction to ambient, (@200 ft/min) | Single layer board (1s) | θ_{JMA} | 50 ^{2,3} | °C/W |
| | Junction to ambient, (@200 ft/min) | Four layer board (2s2p) | θ_{JMA} | 31 ^{2,3} | °C/W |
| | Junction to board | — | θ_{JB} | 20 ⁴ | °C/W |
| | Junction to case | — | θ_{JC} | 12 ⁵ | °C/W |
| | Junction to top of package | Natural convection | Ψ_{jt} | 2 ⁶ | °C/W |
| | Maximum operating junction temperature | — | T_j | 105 | °C |
| 64 LQFP | Junction to ambient, natural convection | Single layer board (1s) | θ_{JA} | 62 ^{1,2} | °C/W |
| | Junction to ambient, natural convection | Four layer board (2s2p) | θ_{JA} | 43 ^{1,3} | °C/W |
| | Junction to ambient (@200 ft/min) | Single layer board (1s) | θ_{JMA} | 50 ^{1,3} | °C/W |
| | Junction to ambient (@200 ft/min) | Four layer board (2s2p) | θ_{JMA} | 36 ^{1,3} | °C/W |
| | Junction to board | — | θ_{JB} | 26 ⁴ | °C/W |
| | Junction to case | — | θ_{JC} | 9 ⁵ | °C/W |
| | Junction to top of package | Natural convection | Ψ_{jt} | 2 ⁶ | °C/W |
| | Maximum operating junction temperature | — | T_j | 105 | °C |

¹ θ_{JA} and Ψ_{jt} parameters are simulated in conformance with EIA/JESD Standard 51-2 for natural convection. Freescale recommends the use of θ_{JA} and power dissipation specifications in the system design to prevent device junction temperatures from exceeding the rated specification. System designers should be aware that device junction temperatures can be significantly influenced by board layout and surrounding devices. Conformance to the device junction temperature specification can be verified by physical measurement in the customer's system using the Ψ_{jt} parameter, the device power dissipation, and the method described in EIA/JESD Standard 51-2.

² Per JEDEC JESD51-2 with the single-layer board (JESD51-3) horizontal.

³ Per JEDEC JESD51-6 with the board JESD51-7) horizontal.

⁴ Thermal resistance between the die and the printed circuit board in conformance with JEDEC JESD51-8. Board temperature is measured on the top surface of the board near the package.

⁵ Thermal resistance between the die and the case top surface as measured by the cold plate method (MIL SPEC-883 Method 1012.1).

- ⁶ Thermal characterization parameter indicating the temperature difference between package top and the junction temperature per JEDEC JESD51-2. When Greek letters are not available, the thermal characterization parameter is written in conformance with Psi-JT.

The average chip-junction temperature (T_J) in °C can be obtained from:

$$T_J = T_A + (P_D \times \Theta_{JMA}) \quad (1)$$

Where:

- T_A = ambient temperature, °C
- Θ_{JA} = package thermal resistance, junction-to-ambient, °C/W
- P_D = $P_{INT} + P_{I/O}$
- P_{INT} = chip internal power, $I_{DD} \times V_{DD}$, watts
- $P_{I/O}$ = power dissipation on input and output pins — user determined, watts

For most applications $P_{I/O} < P_{INT}$ and can be ignored. An approximate relationship between P_D and T_J (if $P_{I/O}$ is neglected) is:

$$P_D = K \div (T_J + 273^\circ\text{C}) \quad (2)$$

Solving equations 1 and 2 for K gives:

$$K = P_D \times (T_A + 273^\circ\text{C}) + \Theta_{JMA} \times P_D^2 \quad (3)$$

where K is a constant pertaining to the particular part. K can be determined from equation (3) by measuring P_D (at equilibrium) for a known T_A . Using this value of K, the values of P_D and T_J can be obtained by solving equations (1) and (2) iteratively for any value of T_A .

2.4 Flash Memory Characteristics

The flash memory characteristics are shown in [Table 23](#) and [Table 24](#).

Table 23. SGFM Flash Program and Erase Characteristics

($V_{DDF} = 2.7$ to 3.6 V)

| Parameter | Symbol | Min | Typ | Max | Unit |
|---|-----------------------|------|-----|--------------------------|------|
| System clock (read only) | $f_{\text{sys(R)}}$ | 0 | — | 66.67 or 80 ¹ | MHz |
| System clock (program/erase) ² | $f_{\text{sys(P/E)}}$ | 0.15 | — | 66.67 or 80 ¹ | MHz |

¹ Depending on packaging; see [Table](#) .

² Refer to the flash memory section for more information

Table 24. SGFM Flash Module Life Characteristics

($V_{DDF} = 2.7$ to 3.6 V)

| Parameter | Symbol | Value | Unit |
|---|-----------|---------------------|--------|
| Maximum number of guaranteed program/erase cycles ¹ before failure | P/E | 10,000 ² | Cycles |
| Data retention at average operating temperature of 85°C | Retention | 10 | Years |

¹ A program/erase cycle is defined as switching the bits from 1 → 0 → 1.

² Reprogramming of a flash memory array block prior to erase is not required.

2.5 ESD Protection

Table 25. ESD Protection Characteristics^{1, 2}

| Characteristics | Symbol | Value | Units |
|---------------------------------|--------------|-------|----------|
| ESD target for Human Body Model | HBM | 2000 | V |
| ESD target for Machine Model | MM | 200 | V |
| HBM circuit description | R_{series} | 1500 | Ω |
| | C | 100 | pF |
| MM circuit description | R_{series} | 0 | Ω |
| | C | 200 | pF |
| Number of pulses per pin (HBM) | | | — |
| • Positive pulses | — | 1 | |
| • Negative pulses | — | 1 | |
| Number of pulses per pin (MM) | | | — |
| • Positive pulses | — | 3 | |
| • Negative pulses | — | 3 | |
| Interval of pulses | — | 1 | sec |

¹ All ESD testing is in conformity with CDF-AEC-Q100 Stress Test Qualification for Automotive Grade Integrated Circuits.

² A device is defined as a failure if after exposure to ESD pulses the device no longer meets the device specification requirements. Complete DC parametric and functional testing is performed per applicable device specification at room temperature followed by hot temperature, unless specified otherwise in the device specification.

2.6 DC Electrical Specifications

Table 26. DC Electrical Specifications¹

| Characteristic | Symbol | Min | Max | Unit |
|--|--------------|----------------------|----------------------|---------|
| Supply voltage | V_{DD} | 3.0 | 3.6 | V |
| Standby voltage | V_{STBY} | 3.0 | 3.6 | V |
| Input high voltage | V_{IH} | $0.7 \times V_{DD}$ | 4.0 | V |
| Input low voltage | V_{IL} | $V_{SS} - 0.3$ | $0.35 \times V_{DD}$ | V |
| Input hysteresis | V_{HYS} | $0.06 \times V_{DD}$ | — | mV |
| Low-voltage detect trip voltage (V_{DD} falling) | V_{LVD} | 2.15 | 2.3 | V |
| Low-voltage detect hysteresis (V_{DD} rising) | V_{LVDHYS} | 60 | 120 | mV |
| Input leakage current $V_{in} = V_{DD}$ or V_{SS} , digital pins | I_{in} | -1.0 | 1.0 | μA |
| Output high voltage (all input/output and all output pins) $I_{OH} = -2.0$ mA | V_{OH} | $V_{DD} - 0.5$ | — | V |
| Output low voltage (all input/output and all output pins) $I_{OL} = 2.0$ mA | V_{OL} | — | 0.5 | V |

Table 26. DC Electrical Specifications (continued)¹

| Characteristic | Symbol | Min | Max | Unit |
|--|-----------|----------------|------|---------------|
| Output high voltage (high drive) $I_{OH} = -5 \text{ mA}$ | V_{OH} | $V_{DD} - 0.5$ | — | V |
| Output low voltage (high drive) $I_{OL} = 5 \text{ mA}$ | V_{OL} | — | 0.5 | V |
| Output high voltage (low drive) $I_{OH} = -2 \text{ mA}$ | V_{OH} | $V_{DD} - 0.5$ | — | V |
| Output low voltage (low drive) $I_{OL} = 2 \text{ mA}$ | V_{OL} | — | 0.5 | V |
| Weak internal pull Up device current, tested at V_{IL} Max. ² | I_{APU} | -10 | -130 | μA |
| Input Capacitance ³ • All input-only pins • All input/output (three-state) pins | C_{in} | — | 7 | pF |

¹ Refer to Table 27 for additional PLL specifications.

² Refer to Table 2 for pins having internal pull-up devices.

³ This parameter is characterized before qualification rather than 100% tested.

2.7 Clock Source Electrical Specifications

Table 27. PLL Electrical Specifications

(V_{DD} and $V_{DDPLL} = 2.7$ to 3.6 V , $V_{SS} = V_{SSPLL} = 0 \text{ V}$)

| Characteristic | Symbol | Min | Max | Unit |
|---|--------------------------------------|---------------------|------------------------------------|---------------|
| PLL reference frequency range • Crystal reference • External reference | $f_{ref_crystal}$ f_{ref_ext} | 2 2 | 10.0 10.0 | MHz |
| System frequency ¹ • External clock mode • On-chip PLL frequency | f_{sys} | 0 $f_{ref} / 32$ | 66.67 or 80^2 66.67 or 80^2 | MHz |
| Loss of reference frequency ^{3, 5} | f_{LOR} | 100 | 1000 | kHz |
| Self clocked mode frequency ⁴ | f_{SCM} | 1 | 5 | MHz |
| Crystal start-up time ^{5, 6} | t_{cst} | — | 10 | ms |
| EXTAL input high voltage • External reference | V_{IHEXT} | 2.0 | V_{DD} | V |
| EXTAL input low voltage • External reference | V_{ILEXT} | V_{SS} | 0.8 | V |
| PLL lock time ^{4, 7} | t_{pll} | — | 500 | μs |
| Duty cycle of reference ⁴ | t_{dc} | 40 | 60 | % f_{ref} |

Electrical Characteristics

Table 27. PLL Electrical Specifications (continued)

(V_{DD} and $V_{DDPLL} = 2.7$ to 3.6 V, $V_{SS} = V_{SSPLL} = 0$ V)

| Characteristic | Symbol | Min | Max | Unit |
|---|--------------|--------|-----------|-------------|
| Frequency un-LOCK range | f_{UL} | -1.5 | 1.5 | % f_{ref} |
| Frequency LOCK range | f_{LCK} | -0.75 | 0.75 | % f_{ref} |
| CLKOUT period jitter ^{4, 5, 8, 9} , measured at f_{SYS} Max <ul style="list-style-type: none"> • Peak-to-peak (clock edge to clock edge) • Long term (averaged over 2 ms interval) | C_{jitter} | — — | 10 .01 | % f_{sys} |
| On-chip oscillator frequency | f_{oco} | 7.84 | 8.16 | MHz |

¹ All internal registers retain data at 0 Hz.

² Depending on packaging; see [Table](#) .

³ Loss of Reference Frequency is the reference frequency detected internally, which transitions the PLL into self clocked mode.

⁴ Self clocked mode frequency is the frequency at which the PLL operates when the reference frequency falls below f_{LOR} with default MFD/RFD settings.

⁵ This parameter is characterized before qualification rather than 100% tested.

⁶ Proper PC board layout procedures must be followed to achieve specifications.

⁷ This specification applies to the period required for the PLL to relock after changing the MFD frequency control bits in the synthesizer control register (SYNCR).

⁸ Jitter is the average deviation from the programmed frequency measured over the specified interval at maximum f_{sys} . Measurements are made with the device powered by filtered supplies and clocked by a stable external clock signal. Noise injected into the PLL circuitry via V_{DDPLL} and V_{SSPLL} and variation in crystal oscillator frequency increase the C_{jitter} percentage for a given interval.

⁹ Based on slow system clock of 40 MHz measured at f_{sys} max.

2.8 General Purpose I/O Timing

GPIO can be configured for certain pins of the QSPI, DDR Control, timer, UART, Interrupt and USB interfaces. When in GPIO mode, the timing specification for these pins is given in [Table 28](#) and [Figure 6](#).

The GPIO timing is met under the following load test conditions:

- 50 pF / 50 Ω for high drive
- 25 pF / 25 Ω for low drive

Table 28. GPIO Timing

| NUM | Characteristic | Symbol | Min | Max | Unit |
|-----|------------------------------------|-------------|-----|-----|------|
| G1 | CLKOUT High to GPIO Output Valid | t_{CHPOV} | — | 10 | ns |
| G2 | CLKOUT High to GPIO Output Invalid | t_{CHPOI} | 1.5 | — | ns |
| G3 | GPIO Input Valid to CLKOUT High | t_{PVCH} | 9 | — | ns |
| G4 | CLKOUT High to GPIO Input Invalid | t_{CHPI} | 1.5 | — | ns |

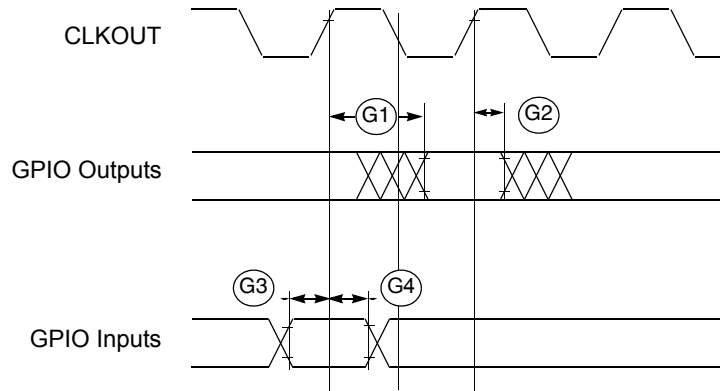

Figure 6. GPIO Timing

2.9 Reset Timing

Table 29. Reset and Configuration Override Timing

($V_{DD} = 2.7$ to 3.6 V, $V_{SS} = 0$ V, $T_A = T_L$ to T_H)¹

| NUM | Characteristic | Symbol | Min | Max | Unit |
|-----|---|-------------|-----|-----|-----------|
| R1 | \overline{RSTI} input valid to CLKOUT High | t_{RVCH} | 9 | — | ns |
| R2 | CLKOUT High to \overline{RSTI} Input invalid | t_{CHRI} | 1.5 | — | ns |
| R3 | \overline{RSTI} input valid time ² | t_{RIVT} | 5 | — | t_{CYC} |
| R4 | CLKOUT High to \overline{RSTO} Valid | t_{CHROV} | — | 10 | ns |

¹ All AC timing is shown with respect to 50% V_{DD} levels unless otherwise noted.

² During low power STOP, the synchronizers for the \overline{RSTI} input are bypassed and \overline{RSTI} is asserted asynchronously to the system. Thus, \overline{RSTI} must be held a minimum of 100 ns.

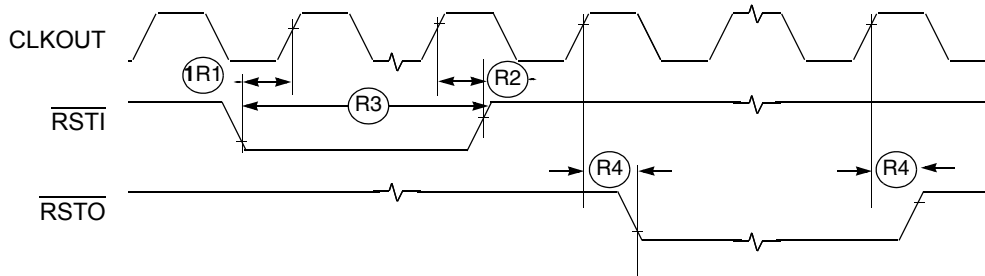

Figure 7. \overline{RSTI} and Configuration Override Timing

2.10 I²C Input/Output Timing Specifications

Table 30 lists specifications for the I²C input timing parameters shown in Figure 8.

Table 30. I²C Input Timing Specifications between I2C_SCL and I2C_SDA

| Num | Characteristic | Min | Max | Units |
|-----|--|--------------------|-----|-------|
| 11 | Start condition hold time | $2 \times t_{CYC}$ | — | ns |
| 12 | Clock low period | $8 \times t_{CYC}$ | — | ns |
| 13 | SCL/SDA rise time ($V_{IL} = 0.5 \text{ V}$ to $V_{IH} = 2.4 \text{ V}$) | — | 1 | ms |
| 14 | Data hold time | 0 | — | ns |
| 15 | SCL/SDA fall time ($V_{IH} = 2.4 \text{ V}$ to $V_{IL} = 0.5 \text{ V}$) | — | 1 | ms |
| 16 | Clock high time | $4 \times t_{CYC}$ | — | ns |
| 17 | Data setup time | 0 | — | ns |
| 18 | Start condition setup time (for repeated start condition only) | $2 \times t_{CYC}$ | — | ns |
| 19 | Stop condition setup time | $2 \times t_{CYC}$ | — | ns |

Table 31 lists specifications for the I²C output timing parameters shown in Figure 8.

Table 31. I²C Output Timing Specifications between I2C_SCL and I2C_SDA

| Num | Characteristic | Min | Max | Units |
|-----------------|---|---------------------|-----|---------------|
| 11 ¹ | Start condition hold time | $6 \times t_{CYC}$ | — | ns |
| 12 ¹ | Clock low period | $10 \times t_{CYC}$ | — | ns |
| 13 ² | I2C_SCL/I2C_SDA rise time ($V_{IL} = 0.5 \text{ V}$ to $V_{IH} = 2.4 \text{ V}$) | — | — | μs |
| 14 ¹ | Data hold time | $7 \times t_{CYC}$ | — | ns |
| 15 ³ | I2C_SCL/I2C_SDA fall time ($V_{IH} = 2.4 \text{ V}$ to $V_{IL} = 0.5 \text{ V}$) | — | 3 | ns |
| 16 ¹ | Clock high time | $10 \times t_{CYC}$ | — | ns |
| 17 ¹ | Data setup time | $2 \times t_{CYC}$ | — | ns |
| 18 ¹ | Start condition setup time (for repeated start condition only) | $20 \times t_{CYC}$ | — | ns |
| 19 ¹ | Stop condition setup time | $10 \times t_{CYC}$ | — | ns |

¹ Output numbers depend on the value programmed into the IFDR; an IFDR programmed with the maximum frequency (IFDR = 0x20) results in minimum output timings as shown in Table 31. The I²C interface is designed to scale the actual data transition time to move it to the middle of the SCL low period. The actual position is affected by the prescale and division values programmed into the IFDR; however, the numbers given in Table 31 are minimum values.

² Because SCL and SDA are open-collector-type outputs, which the processor can only actively drive low, the time SCL or SDA take to reach a high level depends on external signal capacitance and pull-up resistor values.

³ Specified at a nominal 50-pF load.

Figure 8 shows timing for the values in Table 30 and Table 31.

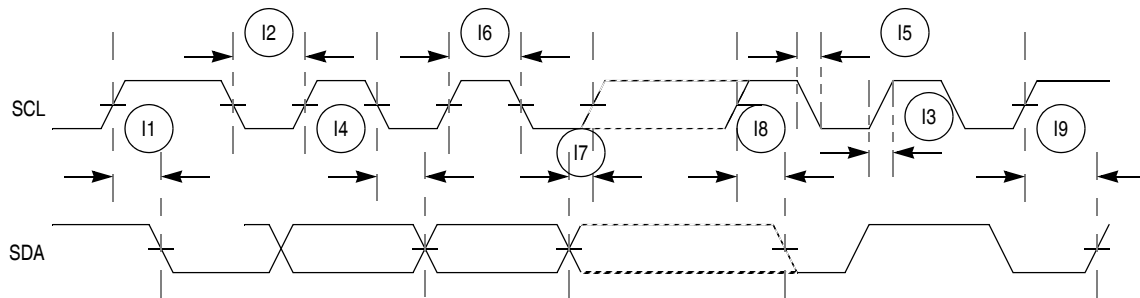

Figure 8. I²C Input/Output Timings

2.11 Analog-to-Digital Converter (ADC) Parameters

Table 32 lists specifications for the analog-to-digital converter.

Table 32. ADC Parameters¹

| Name | Characteristic | Min | Typical | Max | Unit |
|---------------------|---|-------------------|---------------|-------------------|--------------------------------------|
| V _{REFL} | Low reference voltage | V _{SS} | — | V _{REFH} | V |
| V _{REFH} | High reference voltage | V _{REFL} | — | V _{DDA} | V |
| V _{DDA} | ADC analog supply voltage | 3.0 | 3.3 | 3.6 | V |
| V _{ADIN} | Input voltages | V _{REFL} | — | V _{REFH} | V |
| RES | Resolution | 12 | — | 12 | Bits |
| INL | Integral non-linearity (full input signal range) ² | — | ±2.5 | ±3 | LSB ³ |
| INL | Integral non-linearity (10% to 90% input signal range) ⁴ | — | ±2.5 | ±3 | LSB |
| DNL | Differential non-linearity | — | -1 < DNL < +1 | <+1 | LSB |
| Monotonicity | | GUARANTEED | | | |
| f _{ADIC} | ADC internal clock | 0.1 | — | 5.0 | MHz |
| R _{AD} | Conversion range | V _{REFL} | — | V _{REFH} | V |
| t _{ADPU} | ADC power-up time ⁵ | — | 6 | 13 | t _{AIC} cycles ⁶ |
| t _{REC} | Recovery from auto standby | — | 0 | 1 | t _{AIC} cycles |
| t _{ADC} | Conversion time | — | 6 | — | t _{AIC} cycles |
| t _{ADS} | Sample time | — | 1 | — | t _{AIC} cycles |
| C _{ADI} | Input capacitance | — | See Figure 9 | — | pF |
| X _{IN} | Input impedance | — | See Figure 9 | — | W |
| I _{ADI} | Input injection current ⁷ , per pin | — | — | 3 | mA |
| I _{VREFH} | V _{REFH} current | — | 0 | — | m |
| V _{OFFSET} | Offset voltage internal reference | — | ±8 | ±15 | mV |
| E _{GAIN} | Gain error (transfer path) | .99 | 1 | 1.01 | — |
| V _{OFFSET} | Offset voltage external reference | — | ±3 | TBD | mV |
| SNR | Signal-to-noise ratio | — | 62 to 66 | — | dB |

Table 32. ADC Parameters¹ (continued)

| Name | Characteristic | Min | Typical | Max | Unit |
|-------|---------------------------------|-----|------------|-----|------|
| THD | Total harmonic distortion | — | -75 | — | dB |
| SFDR | Spurious free dynamic range | — | 67 to 70.3 | — | dB |
| SINAD | Signal-to-noise plus distortion | — | 61 to 63.9 | — | dB |
| ENOB | Effective number of bits | 9.1 | 10.6 | — | Bits |

¹ All measurements are made at $V_{DD} = 3.3V$, $V_{REFH} = 3.3V$, and $V_{REFL} = \text{ground}$

² INL measured from $V_{IN} = V_{REFL}$ to $V_{IN} = V_{REFH}$

³ LSB = Least Significant Bit

⁴ INL measured from $V_{IN} = 0.1V_{REFH}$ to $V_{IN} = 0.9V_{REFH}$

⁵ Includes power-up of ADC and V_{REF}

⁶ ADC clock cycles

⁷ Current that can be injected or sourced from an unselected ADC signal input without impacting the performance of the ADC

2.12 Equivalent Circuit for ADC Inputs

Figure 10-17 shows the ADC input circuit during sample and hold. S1 and S2 are always open/closed at the same time that S3 is closed/open. When S1/S2 are closed & S3 is open, one input of the sample and hold circuit moves to $(V_{REFH} - V_{REFL})/2$, while the other charges to the analog input voltage. When the switches are flipped, the charge on C1 and C2 are averaged via S3, with the result that a single-ended analog input is switched to a differential voltage centered about $(V_{REFH} - V_{REFL})/2$. The switches switch on every cycle of the ADC clock (open one-half ADC clock, closed one-half ADC clock). There are additional capacitances associated with the analog input pad, routing, etc., but these do not filter into the S/H output voltage, as S1 provides isolation during the charge-sharing phase. One aspect of this circuit is that there is an on-going input current, which is a function of the analog input voltage, V_{REF} and the ADC clock frequency.

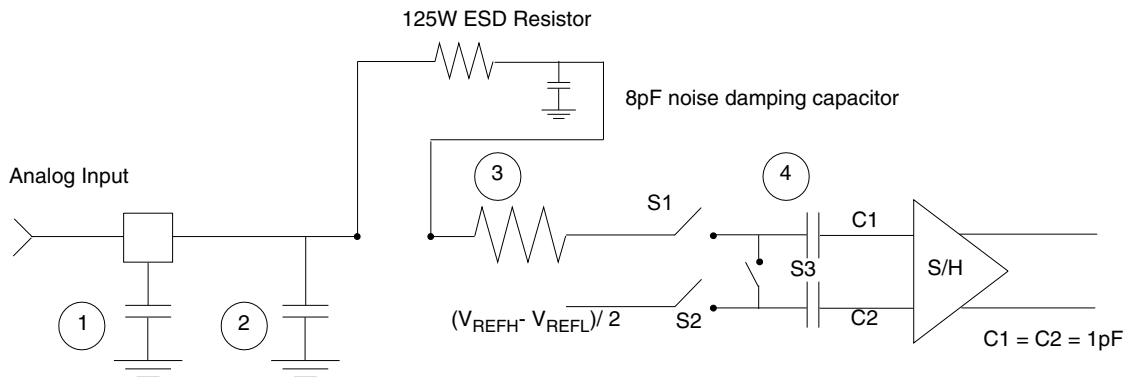

1. Parasitic capacitance due to package, pin-to-pin and pin-to-package base coupling; 1.8pF
2. Parasitic capacitance due to the chip bond pad, ESD protection devices and signal routing; 2.04pF
3. Equivalent resistance for the channel select mux; 100 Ω s
4. Sampling capacitor at the sample and hold circuit. Capacitor C1 is normally disconnected from the input and is only connected to it at sampling time; 1.4pF
5. Equivalent input impedance, when the input is selected =
$$\frac{1}{(\text{ADC Clock Rate}) \times (1.4 \times 10^{-12})}$$

Figure 9. Equivalent Circuit for A/D Loading

2.13 DMA Timers Timing Specifications

Table 33 lists timer module AC timings.

Table 33. Timer Module AC Timing Specifications

| Name | Characteristic ¹ | Min | Max | Unit |
|------|---|--------------------|-----|------|
| T1 | DTIN0 / DTIN1 / DTIN2 / DTIN3 cycle time | $3 \times t_{CYC}$ | — | ns |
| T2 | DTIN0 / DTIN1 / DTIN2 / DTIN3 pulse width | $1 \times t_{CYC}$ | — | ns |

¹ All timing references to CLKOUT are given to its rising edge.

2.14 QSPI Electrical Specifications

Table 34 lists QSPI timings.

Table 34. QSPI Modules AC Timing Specifications

| Name | Characteristic | Min | Max | Unit |
|------|--|-----|-----|-----------|
| QS1 | QSPI_CS[3:0] to QSPI_CLK | 1 | 510 | t_{CYC} |
| QS2 | QSPI_CLK high to QSPI_DOUT valid | — | 10 | ns |
| QS3 | QSPI_CLK high to QSPI_DOUT invalid (Output hold) | 2 | — | ns |
| QS4 | QSPI_DIN to QSPI_CLK (Input setup) | 9 | — | ns |
| QS5 | QSPI_DIN to QSPI_CLK (Input hold) | 9 | — | ns |

The values in Table 34 correspond to Figure 10.

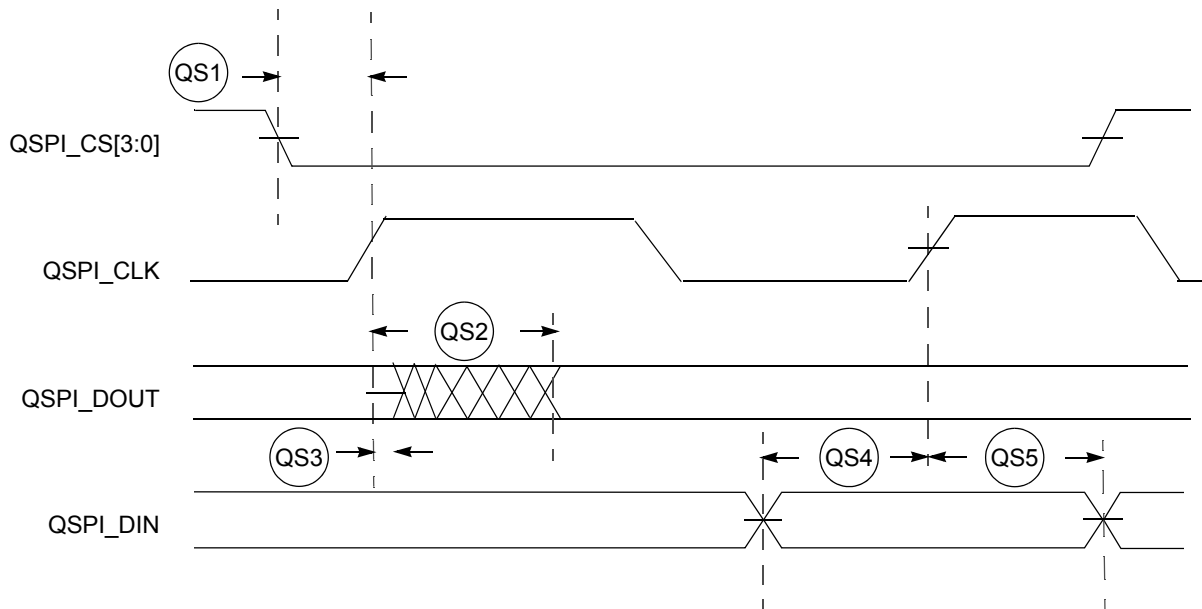

Figure 10. QSPI Timing

2.15 JTAG and Boundary Scan Timing

Table 35. JTAG and Boundary Scan Timing

| Num | Characteristics ¹ | Symbol | Min | Max | Unit |
|-----|--|--------------|--------------------|-----|-------------|
| J1 | TCLK frequency of operation | f_{JCYC} | DC | 1/4 | $f_{sys}/2$ |
| J2 | TCLK cycle period | t_{JCYC} | $4 \times t_{CYC}$ | — | ns |
| J3 | TCLK clock pulse width | t_{JCW} | 26 | — | ns |
| J4 | TCLK rise and fall times | t_{JCRF} | 0 | 3 | ns |
| J5 | Boundary scan input data setup time to TCLK rise | t_{BSDST} | 4 | — | ns |
| J6 | Boundary scan input data hold time after TCLK rise | t_{BSDHT} | 26 | — | ns |
| J7 | TCLK low to boundary scan output data valid | t_{BSDV} | 0 | 33 | ns |
| J8 | TCLK low to boundary scan output high Z | t_{BSDZ} | 0 | 33 | ns |
| J9 | TMS, TDI input data setup time to TCLK rise | t_{TAPBST} | 4 | — | ns |
| J10 | TMS, TDI Input data hold time after TCLK rise | t_{TAPBHT} | 10 | — | ns |
| J11 | TCLK low to TDO data valid | t_{TDODV} | 0 | 26 | ns |
| J12 | TCLK low to TDO high Z | t_{TDODZ} | 0 | 8 | ns |
| J13 | \overline{TRST} assert time | t_{TRSTAT} | 100 | — | ns |
| J14 | \overline{TRST} setup time (negation) to TCLK high | t_{TRSTST} | 10 | — | ns |

¹ JTAG_EN is expected to be a static signal. Hence, it is not associated with any timing.

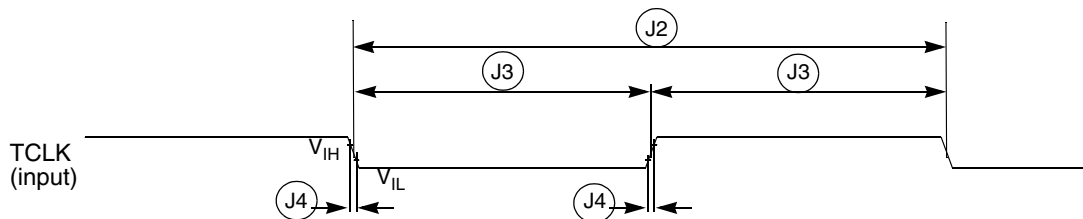

Figure 11. Test Clock Input Timing

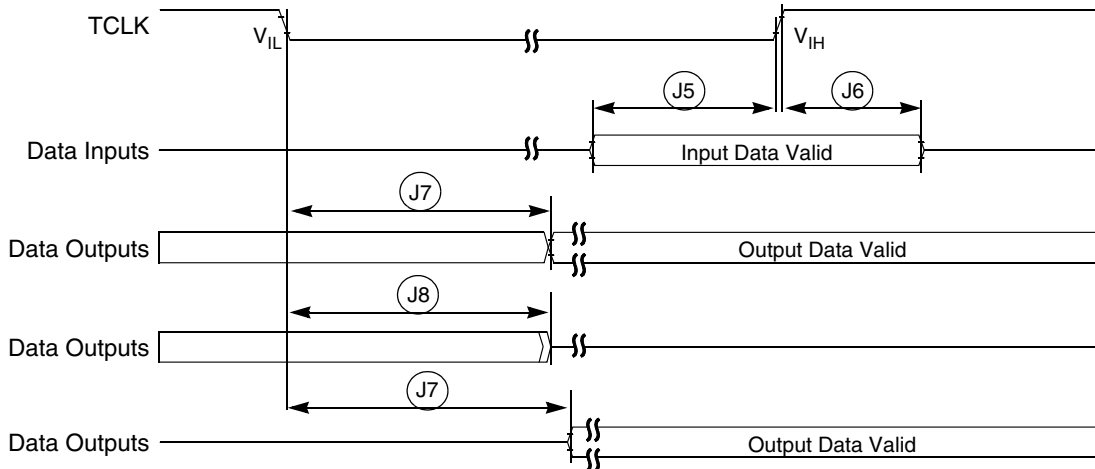

Figure 12. Boundary Scan (JTAG) Timing

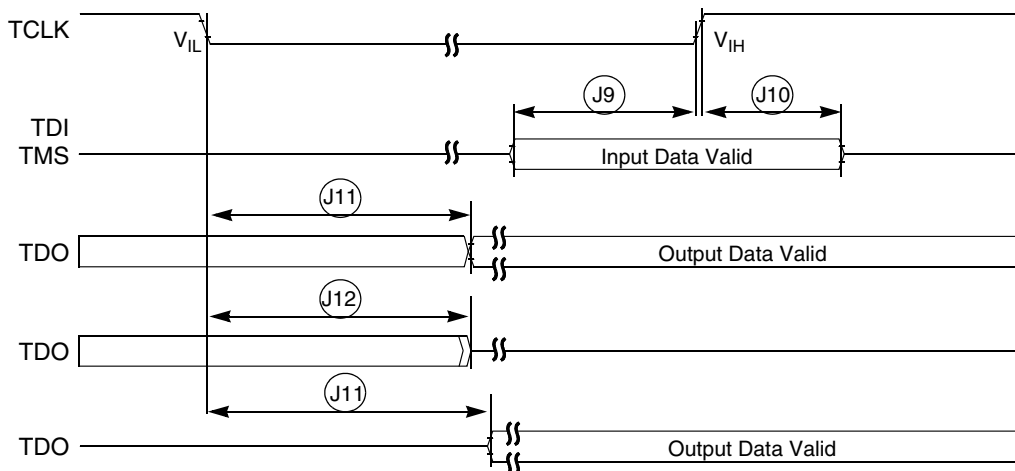

Figure 13. Test Access Port Timing

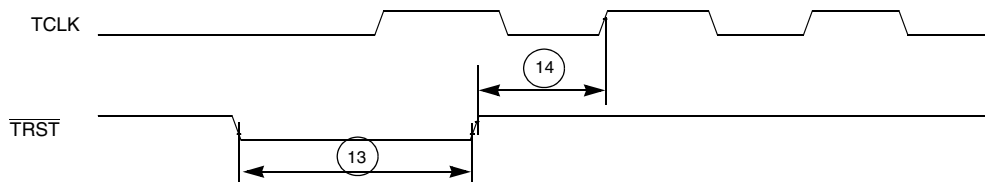

Figure 14. TRST Timing

2.16 Debug AC Timing Specifications

Table 36 lists specifications for the debug AC timing parameters shown in Figure 16.

Table 36. Debug AC Timing Specification

| Num | Characteristic | 66/80 MHz | | Units |
|-----------------|--|--------------------|------|-------|
| | | Min | Max | |
| D1 | PST, DDATA to CLKOUT setup | 4 | — | ns |
| D2 | CLKOUT to PST, DDATA hold | 1.5 | — | ns |
| D3 | DSI-to-DSCLK setup | $1 \times t_{CYC}$ | — | ns |
| D4 ¹ | DSCLK-to-DSO hold | $4 \times t_{CYC}$ | — | ns |
| D5 | DSCLK cycle time | $5 \times t_{CYC}$ | — | ns |
| D6 | \overline{BKPT} input data setup time to CLKOUT rise | 4 | — | ns |
| D7 | \overline{BKPT} input data hold time to CLKOUT rise | 1.5 | — | ns |
| D8 | CLKOUT high to \overline{BKPT} high Z | 0.0 | 10.0 | ns |

¹ DSCLK and DSI are synchronized internally. D4 is measured from the synchronized DSCLK input relative to the rising edge of CLKOUT.

Figure 15 shows real-time trace timing for the values in Table 36.

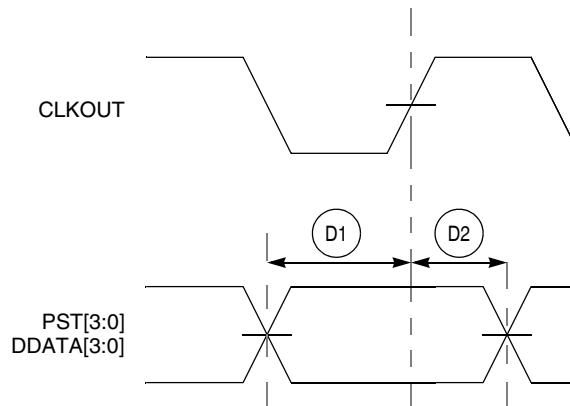

Figure 15. Real-Time Trace AC Timing

Figure 16 shows BDM serial port AC timing for the values in Table 36.

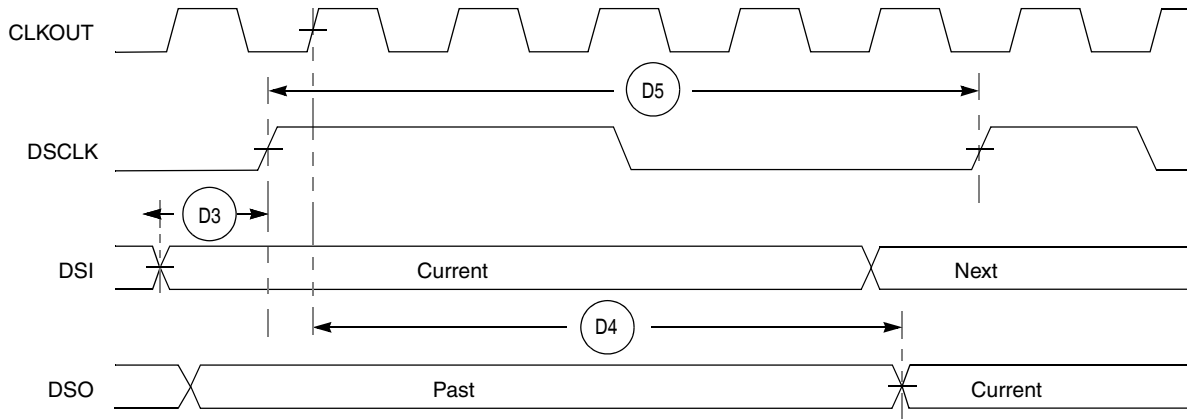
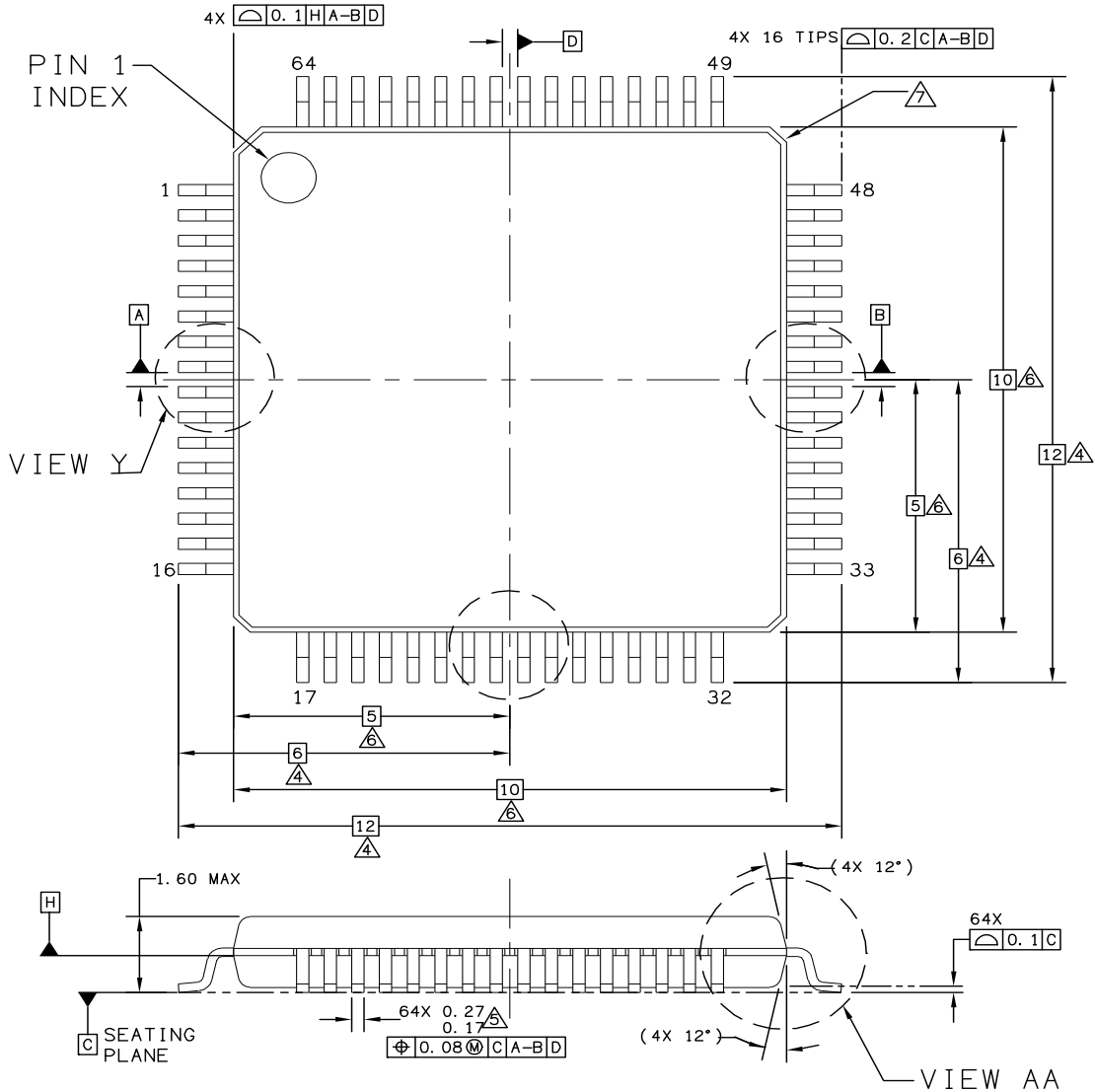

Figure 16. BDM Serial Port AC Timing

3 Mechanical Outline Drawings

This section describes the physical properties of the MCF52223 and its derivatives.

3.1 64-pin LQFP Package



| | | | |
|--|----------------------------|----------------------------|--|
| © FREESCALE SEMICONDUCTOR, INC. ALL RIGHTS RESERVED. | MECHANICAL OUTLINE | PRINT VERSION NOT TO SCALE | |
| TITLE: 64LD LQFP, 10 X 10 X 1.4 PKG, 0.5 PITCH, CASE OUTLINE | DOCUMENT NO: 98ASS23234W | REV: D | |
| | CASE NUMBER: 840F-02 | 06 APR 2005 | |
| | STANDARD: JEDEC MS-026 BCD | | |

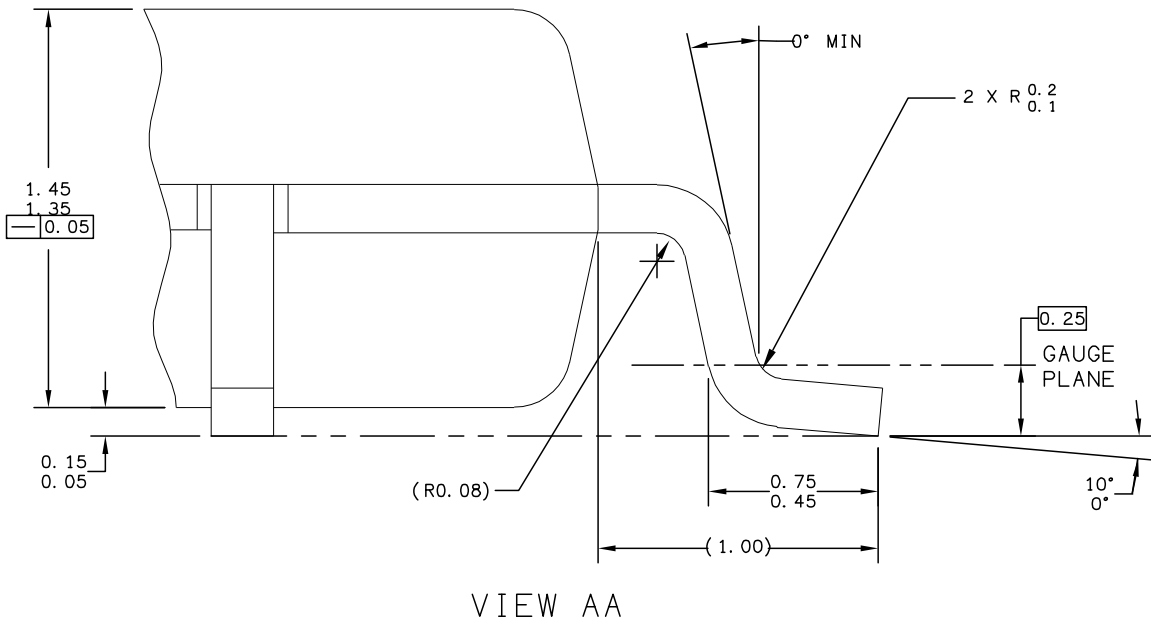
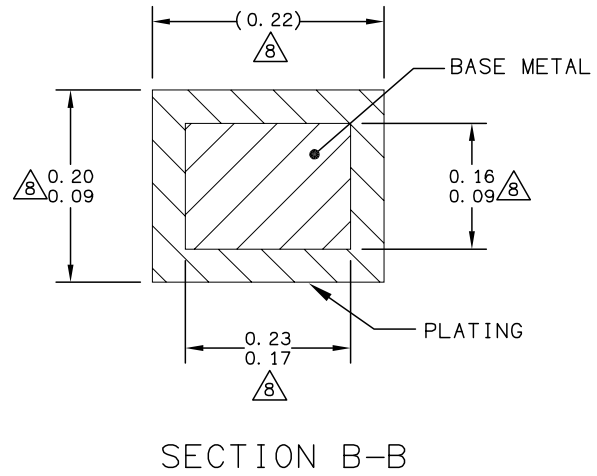
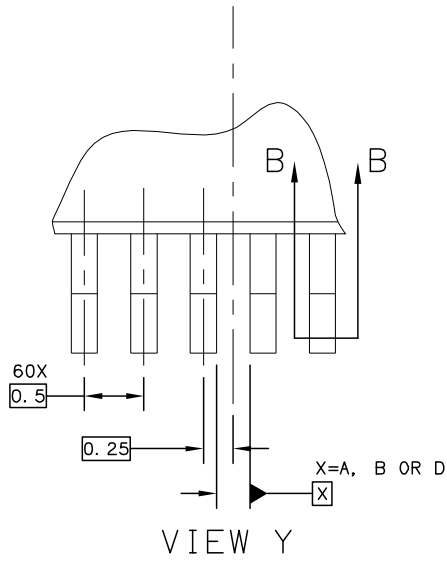

| | | | |
|--|----------------------------|----------------------------|--|
| © FREESCALE SEMICONDUCTOR, INC. ALL RIGHTS RESERVED. | MECHANICAL OUTLINE | PRINT VERSION NOT TO SCALE | |
| TITLE: 64LD LQFP, 10 X 10 X 1.4 PKG, 0.5 PITCH, CASE OUTLINE | DOCUMENT NO: 98ASS23234W | REV: D | |
| | CASE NUMBER: 840F-02 | 06 APR 2005 | |
| | STANDARD: JEDEC MS-026 BCD | | |

Mechanical Outline Drawings

NOTES:

1. DIMENSIONS ARE IN MILLIMETERS.
2. DIMENSIONING AND TOLERANCING PER ASME Y14.5M-1994.
3. DATUMS A, B AND D TO BE DETERMINED AT DATUM PLANE H.
4. DIMENSIONS TO BE DETERMINED AT SEATING PLANE C.
5. THIS DIMENSION DOES NOT INCLUDE DAMBAR PROTRUSION. ALLOWABLE DAMBAR PROTRUSION SHALL NOT CAUSE THE LEAD WIDTH TO EXCEED THE UPPER LIMIT BY MORE THAN 0.08 mm AT MAXIMUM MATERIAL CONDITION. DAMBAR CANNOT BE LOCATED ON THE LOWER RADIUS OR THE FOOT. MINIMUM SPACE BETWEEN PROTRUSION AND ADJACENT LEAD SHALL NOT BE LESS THAN 0.07 mm.
6. THIS DIMENSION DOES NOT INCLUDE MOLD PROTRUSION. ALLOWABLE PROTRUSION IS 0.25 mm PER SIDE. THIS DIMENSION IS MAXIMUM PLASTIC BODY SIZE DIMENSION INCLUDING MOLD MISMATCH.
7. EXACT SHAPE OF EACH CORNER IS OPTIONAL.
8. THESE DIMENSIONS APPLY TO THE FLAT SECTION OF THE LEAD BETWEEN 0.1 mm AND 0.25 mm FROM THE LEAD TIP.

| | | | |
|--|----------------------------|----------------------------|--|
| © FREESCALE SEMICONDUCTOR, INC. ALL RIGHTS RESERVED. | MECHANICAL OUTLINE | PRINT VERSION NOT TO SCALE | |
| TITLE: 64LD LQFP, 10 X 10 X 1.4 PKG, 0.5 PITCH, CASE OUTLINE | DOCUMENT NO: 98ASS23234W | REV: D | |
| | CASE NUMBER: 840F-02 | 06 APR 2005 | |
| | STANDARD: JEDEC MS-026 BCD | | |

3.2 64 QFN Package

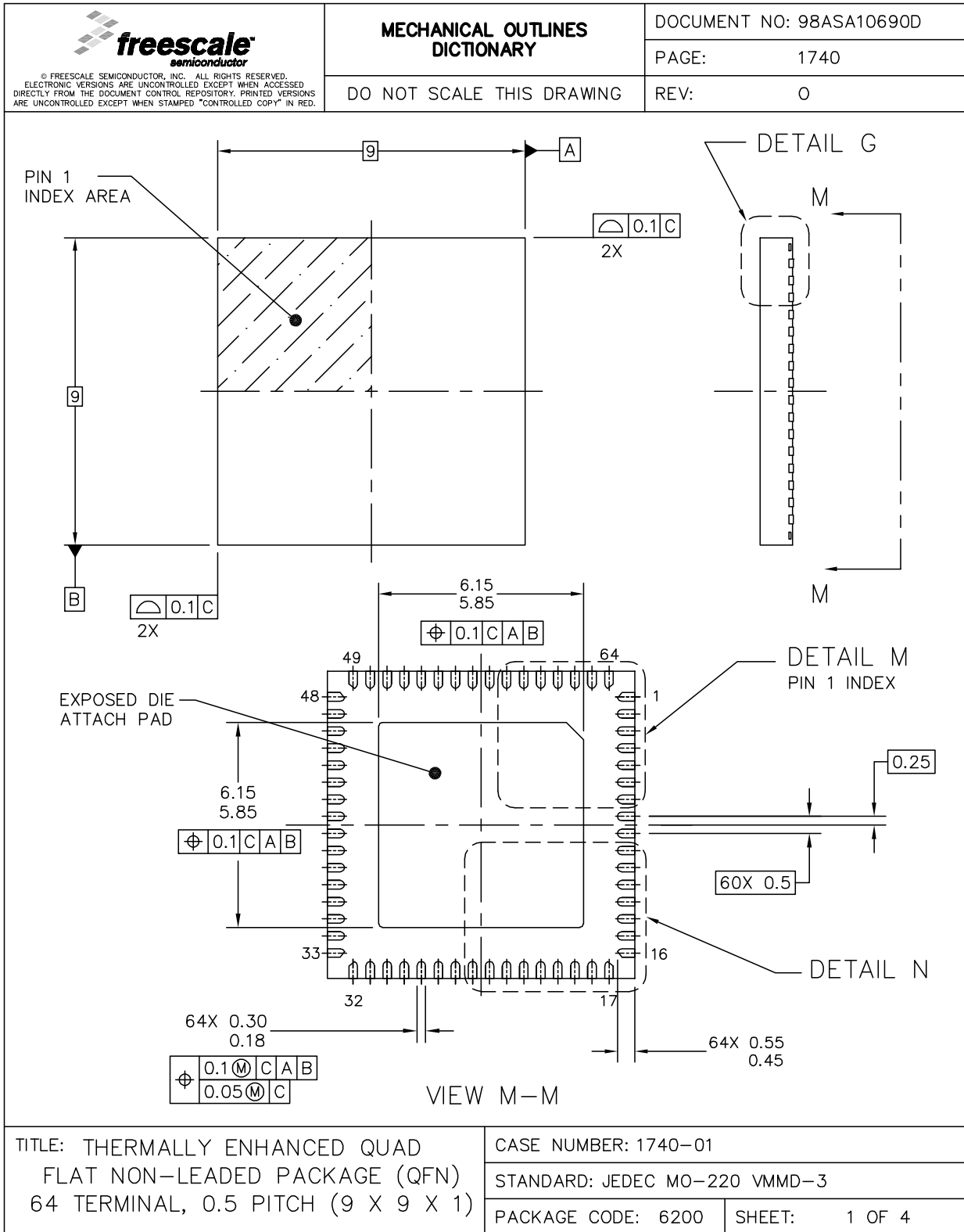

MCF52223 ColdFire Microcontroller, Rev. 2

| | | |
|--|---|--------------------------|
|  <p>© FREESCALE SEMICONDUCTOR, INC. ALL RIGHTS RESERVED. ELECTRONIC VERSIONS ARE UNCONTROLLED EXCEPT WHEN ACCESSED DIRECTLY FROM THE DOCUMENT CONTROL REPOSITORY. PRINTED VERSIONS ARE UNCONTROLLED EXCEPT WHEN STAMPED "CONTROLLED COPY" IN RED.</p> | MECHANICAL OUTLINES DICTIONARY | DOCUMENT NO: 98ASA10690D |
| | DO NOT SCALE THIS DRAWING | PAGE: 1740 |
| | | REV: 0 |

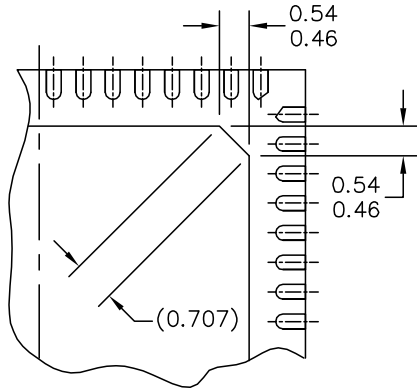

DETAIL M
PREFERRED PIN1 BACKSIDE IDENTIFIER

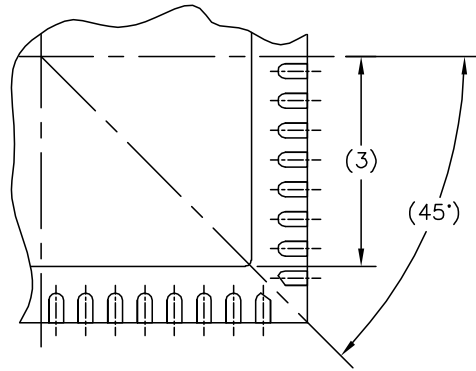

DETAIL N
PREFERRED CORNER CONFIGURATION

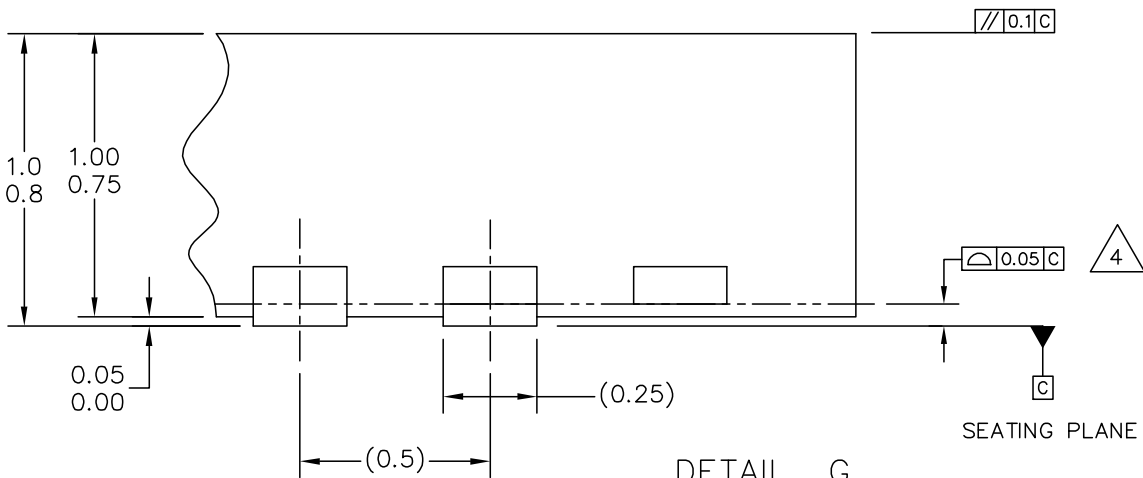

DETAIL G
VIEW ROTATED 90° CW



TITLE: THERMALLY ENHANCED QUAD
FLAT NON-LEADED PACKAGE (QFN)
64 TERMINAL, 0.5 PITCH (9 X 9 X 1)

CASE NUMBER: 1740-01

STANDARD: JEDEC MO-220 VMMD-3

PACKAGE CODE: 6200

SHEET: 2 OF 4

| | | | |
|---|--|-------------------------------|---------------|
|  <small>© FREESCALE SEMICONDUCTOR, INC. ALL RIGHTS RESERVED. ELECTRONIC VERSIONS ARE UNCONTROLLED EXCEPT WHEN ACCESSED DIRECTLY FROM THE DOCUMENT CONTROL REPOSITORY. PRINTED VERSIONS ARE UNCONTROLLED EXCEPT WHEN STAMPED "CONTROLLED COPY" IN RED.</small> | MECHANICAL OUTLINES DICTIONARY | DOCUMENT NO: 98ASA10690D | |
| | | PAGE: | 1740 |
| DO NOT SCALE THIS DRAWING | | REV: | 0 |
| <p>NOTES:</p> <ol style="list-style-type: none"> 1. ALL DIMENSIONS ARE IN MILLIMETERS. 2. INTERPRET DIMENSIONS AND TOLERANCES PER ASME Y14.5M-1994. 3. THE COMPLETE JEDEC DESIGNATOR FOR THIS PACKAGE IS: HF-PQFN. 4.  COPLANARITY APPLIES TO LEADS, CORNER LEADS AND DIE ATTACH PAD. 5. MIN METAL GAP SHOULD BE 0.2MM. | | | |
| TITLE: THERMALLY ENHANCED QUAD FLAT NON-LEADED PACKAGE (QFN) 64 TERMINAL, 0.5 PITCH (9 X 9 X 1) | | CASE NUMBER: 1740-01 | |
| | | STANDARD: JEDEC MO-220 VMMD-3 | |
| | | PACKAGE CODE: 6200 | SHEET: 3 OF 4 |

Mechanical Outline Drawings

|  <p>© FREESCALE SEMICONDUCTOR, INC. ALL RIGHTS RESERVED. ELECTRONIC VERSIONS ARE UNCONTROLLED EXCEPT WHEN ACCESSED DIRECTLY FROM THE DOCUMENT CONTROL REPOSITORY. PRINTED VERSIONS ARE UNCONTROLLED EXCEPT WHEN STAMPED "CONTROLLED COPY" IN RED.</p> | | <h2>REVISION HISTORY</h2> | | DOCUMENT NO: 98ASA10690D | |
|--|---------------|---------------------------|-------------------------------|--------------------------|--------|
| | | | | PAGE: 1740 | |
| | | | | REV: 0 | |
| LTR | ORIGINATOR | REVISIONS | DRAFTER | DATE | |
| 0 | ERIC TRIPLETT | RELEASED FOR PRODUCTION | TAYLOR LIU | 27JUL2005 | |
| | | | | | |
| TITLE: THERMALLY ENHANCED QUAD FLAT NON-LEADED PACKAGE (QFN) 64 TERMINAL, 0.5 PITCH (9 X 9 X 1) | | | CASE NUMBER: 1740-01 | | |
| | | | STANDARD: JEDEC MO-220 VMMD-3 | | |
| | | | PACKAGE CODE: 6200 | SHEET: | 4 OF 4 |

3.3 81 MAPBGA Package

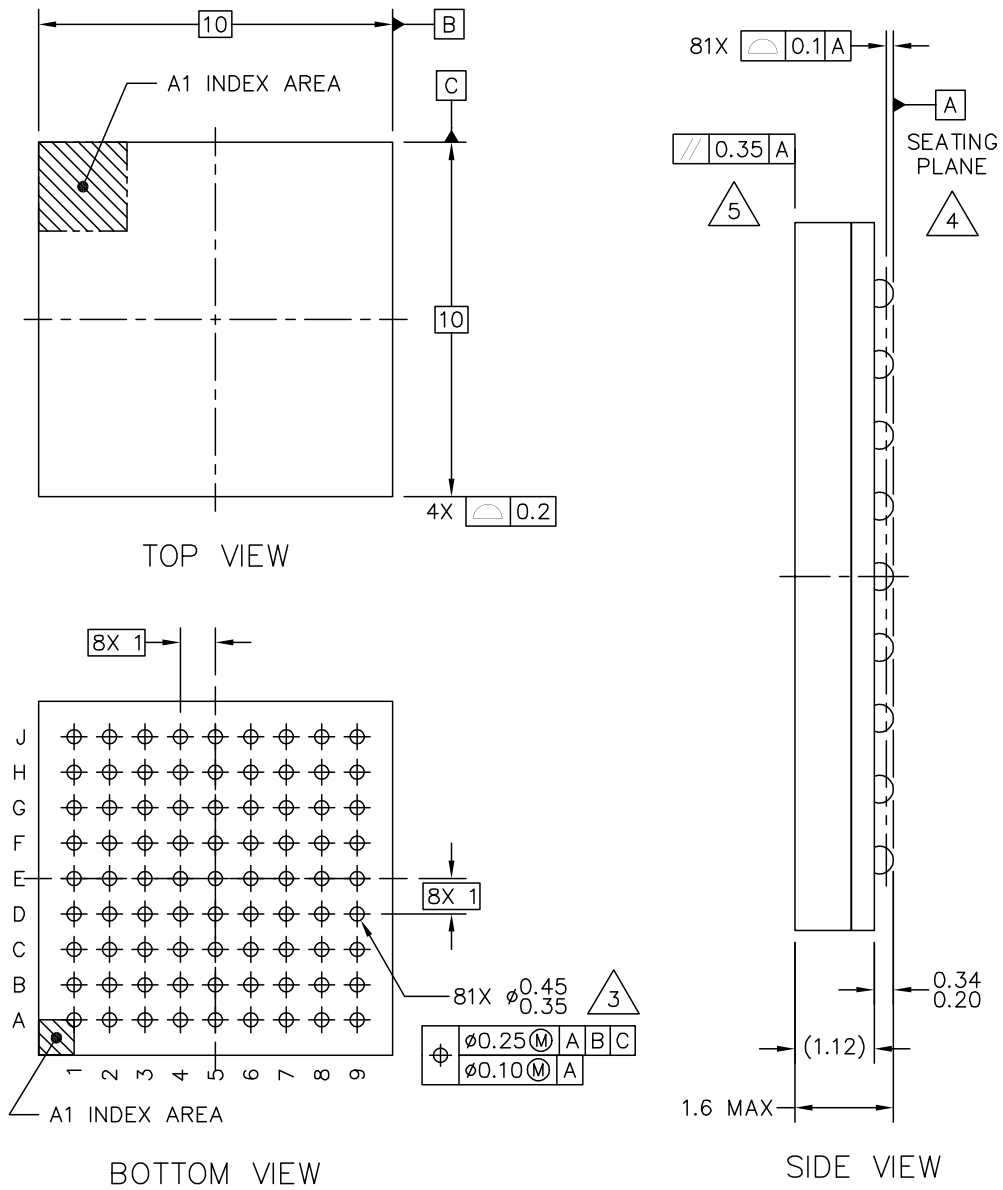

| | | | | | |
|---|--|---------------------------|--|----------------------------|--|
| © FREESCALE SEMICONDUCTOR, INC. ALL RIGHTS RESERVED. | | MECHANICAL OUTLINE | | PRINT VERSION NOT TO SCALE | |
| TITLE: PBGA, LOW PROFILE, 81 I/O, 10 X 10 PKG, 1 MM PITCH (MAP) | | DOCUMENT NO: 98ASA10670D | | REV: 0 | |
| | | CASE NUMBER: 1662-01 | | 04 FEB 2005 | |
| | | STANDARD: NON-JEDEC | | | |

Mechanical Outline Drawings

NOTES:

1. ALL DIMENSIONS IN MILLIMETERS.

2. DIMENSIONING AND TOLERANCING PER ASME Y14.5M-1994.

3. MAXIMUM SOLDER BALL DIAMETER MEASURED PARALLEL TO DATUM A.

4. DATUM A, THE SEATING PLANE, IS DETERMINED BY THE SPHERICAL CROWNS OF THE SOLDER BALLS.

5. PARALLELISM MEASUREMENT SHALL EXCLUDE ANY EFFECT OF MARK ON TOP SURFACE OF PACKAGE.

| | | | |
|---|---------------------------|----------------------------|--|
| © FREESCALE SEMICONDUCTOR, INC. ALL RIGHTS RESERVED. | MECHANICAL OUTLINE | PRINT VERSION NOT TO SCALE | |
| TITLE: PBGA, LOW PROFILE, 81 I/O, 10 X 10 PKG, 1 MM PITCH (MAP) | DOCUMENT NO: 98ASA10670D | REV: 0 | |
| | CASE NUMBER: 1662-01 | 04 FEB 2005 | |
| | STANDARD: NON-JEDEC | | |

3.4 100-pin LQFP Package

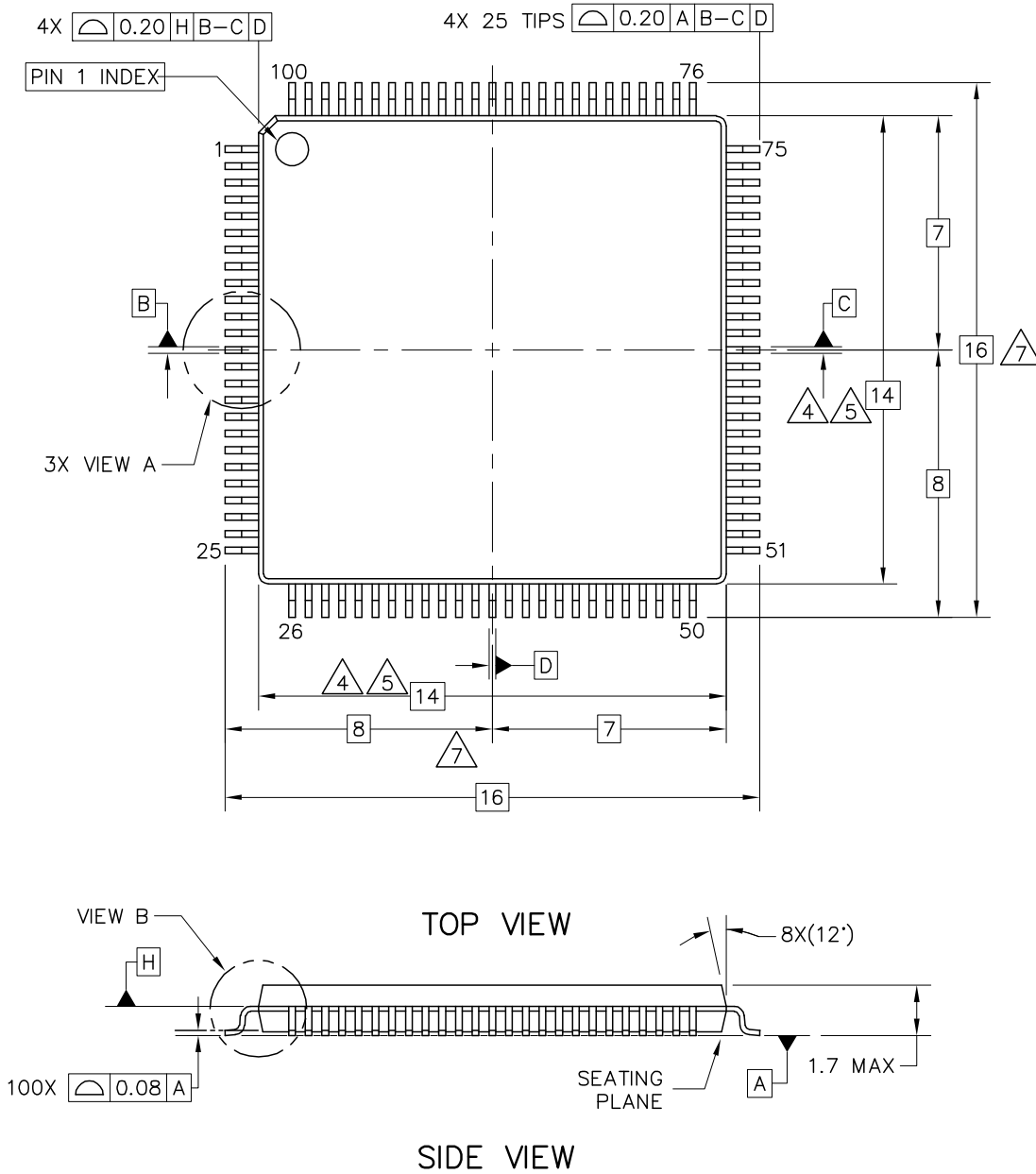

| | | | |
|--|---------------------------|----------------------------|--|
| © FREESCALE SEMICONDUCTOR, INC. ALL RIGHTS RESERVED. | MECHANICAL OUTLINE | PRINT VERSION NOT TO SCALE | |
| TITLE: 100 LEAD LQFP 14 X 14, 0.5 PITCH, 1.4 THICK | DOCUMENT NO: 98ASS23308W | REV: G | |
| | CASE NUMBER: 983-03 | 07 APR 2005 | |
| | STANDARD: NON-JEDEC | | |

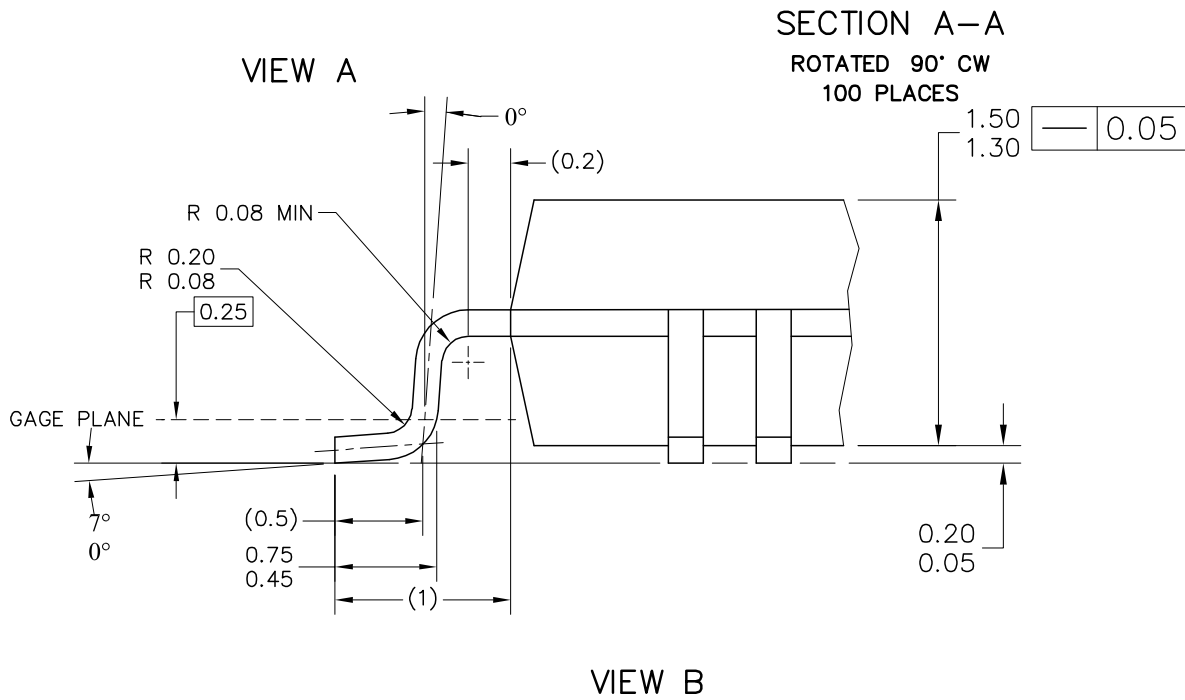
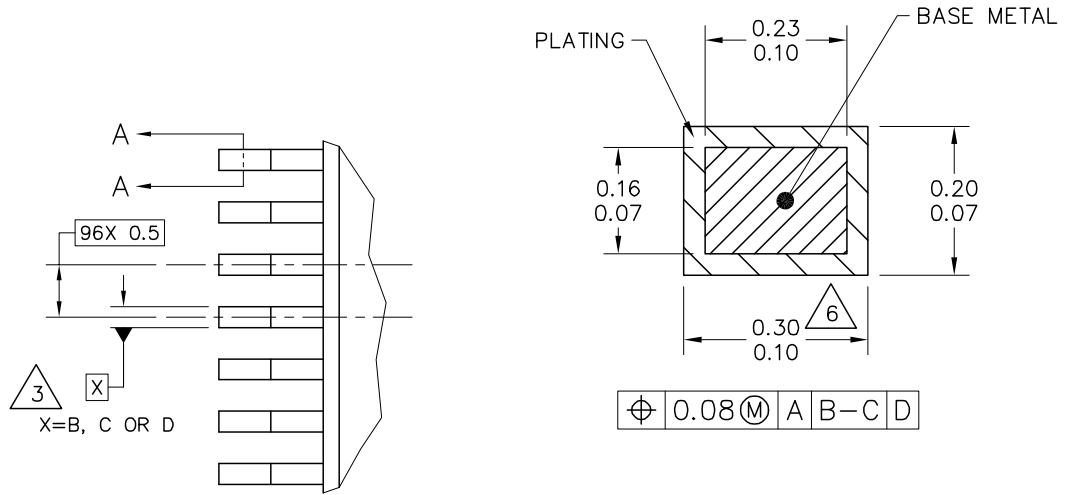

| | | | |
|--|---------------------------|----------------------------|--|
| © FREESCALE SEMICONDUCTOR, INC. ALL RIGHTS RESERVED. | MECHANICAL OUTLINE | PRINT VERSION NOT TO SCALE | |
| TITLE: 100 LEAD LQFP 14 X 14, 0.5 PITCH, 1.4 THICK | DOCUMENT NO: 98ASS23308W | REV: G | |
| | CASE NUMBER: 983-03 | 07 APR 2005 | |
| | STANDARD: NON-JEDEC | | |

4 Revision History

Table 37. Revision History

| Revision | Description |
|----------|--|
| 2 | <ul style="list-style-type: none"> • Formatting, layout, spelling, and grammar corrections. • Removed the “Preliminary” label. • Added missing current consumption data (Section 2.2). • Added revision history. • Corrected signal names in block diagram to match those in the signal description table. • Added an entry for standby voltage (V_{STBY}) to the “DC electrical specifications” table. • Deleted the PSTCLK cycle time row in the “Debug AC timing specifications” table. • Changed the frequency above the “Min” and “Max” column headings in the “Debug AC timing specifications” table (was 166 MHz, is 66/80 MHz). • Added the following signals to the “Pin functions by primary and alternate purpose” table (alternates to IRQ1-6, respectively): USB_ALT_CLK, USB_SESSVLD, USB_SESEND, USB_PULLUP, USB_VBUSVLD, and USB_ID. • Changed the minimum value for SNR, THD, SFDR, and SINAD in the “ADC parameters” table (was TBD, is “—”). • Added values for I_{OH} and I_{OL} to the “DC electrical specifications” table. • Added load test condition information to the “General Purpose I/O Timing” section. • Synchronized the “Pin Functions by Primary and Alternate Purpose” table in this document and the reference manual. • Added a specification for V_{DDUSB} to the “Absolute maximum ratings” table. • Added specifications for V_{LVD} and V_{LVDHYS} to the “DC electrical specifications” table. • Deleted entries for the nonexistent 64 QFN package from the “Thermal Resistances” table. |

How to Reach Us:

Home Page:

www.freescale.com

Web Support:

<http://www.freescale.com/support>

USA/Europe or Locations Not Listed:

Freescale Semiconductor, Inc.
Technical Information Center, EL516
2100 East Elliot Road
Tempe, Arizona 85284
+1-800-521-6274 or +1-480-768-2130
www.freescale.com/support

Europe, Middle East, and Africa:

Freescale Halbleiter Deutschland GmbH
Technical Information Center
Schatzbogen 7
81829 Muenchen, Germany
+44 1296 380 456 (English)
+46 8 52200080 (English)
+49 89 92103 559 (German)
+33 1 69 35 48 48 (French)
www.freescale.com/support

Japan:

Freescale Semiconductor Japan Ltd.
Headquarters
ARCO Tower 15F
1-8-1, Shimo-Meguro, Meguro-ku,
Tokyo 153-0064
Japan
0120 191014 or +81 3 5437 9125
support.japan@freescale.com

Asia/Pacific:

Freescale Semiconductor Hong Kong Ltd.
Technical Information Center
2 Dai King Street
Tai Po Industrial Estate
Tai Po, N.T., Hong Kong
+800 2666 8080
support.asia@freescale.com

For Literature Requests Only:

Freescale Semiconductor Literature Distribution Center
P.O. Box 5405
Denver, Colorado 80217
1-800-441-2447 or 303-675-2140
Fax: 303-675-2150
LDCForFreescaleSemiconductor@hibbertgroup.com

Information in this document is provided solely to enable system and software implementers to use Freescale Semiconductor products. There are no express or implied copyright licenses granted hereunder to design or fabricate any integrated circuits or integrated circuits based on the information in this document.

Freescale Semiconductor reserves the right to make changes without further notice to any products herein. Freescale Semiconductor makes no warranty, representation or guarantee regarding the suitability of its products for any particular purpose, nor does Freescale Semiconductor assume any liability arising out of the application or use of any product or circuit, and specifically disclaims any and all liability, including without limitation consequential or incidental damages. "Typical" parameters that may be provided in Freescale Semiconductor data sheets and/or specifications can and do vary in different applications and actual performance may vary over time. All operating parameters, including "Typicals", must be validated for each customer application by customer's technical experts. Freescale Semiconductor does not convey any license under its patent rights nor the rights of others. Freescale Semiconductor products are not designed, intended, or authorized for use as components in systems intended for surgical implant into the body, or other applications intended to support or sustain life, or for any other application in which the failure of the Freescale Semiconductor product could create a situation where personal injury or death may occur. Should Buyer purchase or use Freescale Semiconductor products for any such unintended or unauthorized application, Buyer shall indemnify and hold Freescale Semiconductor and its officers, employees, subsidiaries, affiliates, and distributors harmless against all claims, costs, damages, and expenses, and reasonable attorney fees arising out of, directly or indirectly, any claim of personal injury or death associated with such unintended or unauthorized use, even if such claim alleges that Freescale Semiconductor was negligent regarding the design or manufacture of the part.

RoHS-compliant and/or Pb-free versions of Freescale products have the functionality and electrical characteristics as their non-RoHS-compliant and/or non-Pb-free counterparts. For further information, see <http://www.freescale.com> or contact your Freescale sales representative.

For information on Freescale's Environmental Products program, go to <http://www.freescale.com/epp>.

Freescale™ and the Freescale logo are trademarks of Freescale Semiconductor, Inc. All other product or service names are the property of their respective owners.
© Freescale Semiconductor, Inc. 2007. All rights reserved.

Document Number: MCF52223DS

Rev. 2

04/2007

