



MACRONIX
INTERNATIONAL Co., LTD.

MX25L5121E
MX25L1021E

MX25L5121E, MX25L1021E

DATASHEET

Contents

FEATURES	4
GENERAL	4
PERFORMANCE	4
SOFTWARE FEATURES	4
HARDWARE FEATURES.....	4
GENERAL DESCRIPTION	5
PIN CONFIGURATIONS	6
PIN DESCRIPTION	6
BLOCK DIAGRAM	7
MEMORY ORGANIZATION	8
Table 1-1. Memory Organization (512Kb)	8
Table 1-2. Memory Organization (1Mb).....	8
DEVICE OPERATION	9
Figure 1. Serial Modes Supported.....	9
DATA PROTECTION	10
Table 2. Protected Area Sizes	10
COMMAND DESCRIPTION	11
Table 3. Command Set.....	11
(1) Write Enable (WREN).....	12
(2) Write Disable (WRDI).....	12
(3) Read Identification (RDID)	12
Table 4. ID Definitions	12
(4) Read Status Register (RDSR)	13
Table 5. Status Register	13
(5) Write Status Register (WRSR).....	14
Table 6. Protection Modes.....	14
(6) Read Data Bytes (READ)	15
(7) Read Data Bytes at Higher Speed (FAST_READ)	15
(8) Sector Erase (SE)	15
(9) Block Erase (BE).....	15
(10) Chip Erase (CE).....	16
(11) Page Program (PP).....	16
(12) Deep Power-Down (DP)	16
(13) Release from Deep Power-Down (RDP)	17
POWER-ON STATE	18
Program/ Erase flow with read array data	19
ELECTRICAL SPECIFICATIONS	20

ABSOLUTE MAXIMUM RATINGS	20
Figure 2. Maximum Negative Overshoot Waveform	20
CAPACITANCE TA = 25°C, f = 1.0 MHz.....	20
Figure 3. Maximum Positive Overshoot Waveform	20
Figure 4. INPUT TEST WAVEFORMS AND MEASUREMENT LEVEL.....	21
Figure 5. OUTPUT LOADING	21
Table 7. DC CHARACTERISTICS (Temperature = 0°C to 70°C for Commercial grade, VCC = 2.7V ~ 3.6V) ..	22
Table 8. AC CHARACTERISTICS (Temperature = 0°C to 70°C for Commercial grade, VCC = 2.7V ~ 3.6V) .	23
Timing Analysis	24
Figure 6. Serial Input Timing	24
Figure 7. Output Timing.....	24
Figure 8. WP# Disable Setup and Hold Timing during WRSR when SRWD=1	25
Figure 9. Write Enable (WREN) Sequence (Command 06).....	25
Figure 10. Write Disable (WRDI) Sequence (Command 04).....	25
Figure 11. Read Identification (RDID) Sequence (Command 9F).....	26
Figure 12-1. Read Status Register (RDSR) Sequence (Command 05).....	27
Figure 12-2. Read Status Register (RDSR) Sequence (Command 05).....	27
Figure 13. Write Status Register (WRSR) Sequence (Command 01).....	28
Figure 14. Read Data Bytes (READ) Sequence (Command 03)	28
Figure 15. Read at Higher Speed (FAST_READ) Sequence (Command 0B).....	29
Figure 16. Sector Erase (SE) Sequence (Command 20).....	29
Figure 17. Block Erase (BE) Sequence (Command D8 or 52).....	30
Figure 18. Chip Erase (CE) Sequence (Command 60 or C7).....	30
Figure 19. Page Program (PP) Sequence (Command 02).....	30
Figure 20. Deep Power Down (DP) Sequence (Command B9)	31
Figure 21. Release from Deep Power Down (RDP) Sequence (Command AB).....	31
Figure 23. Power-Up Timing.....	32
Table 9. Power-Up Timing	32
INITIAL DELIVERY STATE.....	32
OPERATING CONDITIONS.....	33
Figure 24. AC Timing at Device Power-Up.....	33
Figure 25. Power-Down Sequence	34
ERASE AND PROGRAMMING PERFORMANCE	35
DATA RETENTION	35
LATCH-UP CHARACTERISTICS	35
ORDERING INFORMATION	36
PART NAME DESCRIPTION.....	37
PACKAGE INFORMATION.....	38
REVISION HISTORY	40

512K-BIT [x 1] CMOS SERIAL FLASH MEMORY
1M-BIT [x 1] CMOS SERIAL FLASH MEMORY**FEATURES****GENERAL**

- Serial Peripheral Interface compatible -- Mode 0 and Mode 3
- 512K: 524,288 x 1 bit structure
1M: 1,048,576 x 1 bit structure
- 16 Equal Sectors with 4K bytes each (512Kb)
32 Equal Sectors with 4K bytes each (1Mb)
 - Any Sector can be erased individually
- 1 Equal Blocks with 64K byte each (512Kb)
2 Equal Blocks with 64K byte each (1Mb)
 - Any Block can be erased individually
- Program Capability
 - Byte base
 - Page base (32 bytes)
- Single Power Supply Operation
 - 2.7 to 3.6 volt for read, erase, and program operations
- Latch-up protected to 100mA from -1V to Vcc +1V

PERFORMANCE

- Performance
 - Fast Read: 45MHz serial clock
 - Fast program time: 180us(typ.) and 650us(max.)/page
 - Fast erase time: 90ms (typ.)/sector ; 1s (typ.)/block
- Low Power Consumption
 - Low active read current: 5mA(max.) at 25MHz, 10mA(max.) at 45MHz
 - Low active programming current: 12mA (max.)
 - Low active erase current: 15mA (max.)
 - Low standby current: 20uA (typ.)
 - Deep power down current: 2uA (typ.)
- Typical 100,000 erase/program cycles
- 20 years data retention

SOFTWARE FEATURES

- Input Data Format
 - 1-byte Command code
- Block Lock protection
 - The BP0~BP1 status bits defines the size of the area to be software protected against Program and Erase instructions
- Auto Erase and Auto Program Algorithm
 - Automatically erases and verifies data at selected sector
 - Automatically programs and verifies data at selected page by an internal algorithm that automatically times the program pulse widths (Any page to be programmed should have page in the erased state first)
- Status Register Feature
- Electronic Identification
 - JEDEC 1-byte manufacturer ID and 2-bytes device ID

HARDWARE FEATURES

- SCLK Input
 - Serial clock input
- SI Input

- Serial Data Input
- SO Output
 - Serial Data Output
- WP# pin
 - Hardware write protection
- PACKAGE
 - 8-pin SOP (150mil)
 - 8-pin TSSOP (173mil)
 - 8-USON (2x3mm)
 - **All devices are RoHS Compliant**

GENERAL DESCRIPTION

The device feature a serial peripheral interface and software protocol allowing operation on a simple 3-wire bus. The three bus signals are a clock input (SCLK), a serial data input (SI), and a serial data output (SO). Serial access to the device is enabled by CS# input.

The device provides sequential read operation on whole chip.

After program/erase command is issued, auto program/erase algorithms which program/erase and verify the specified page or sector locations will be executed. Program command is executed on page (32 bytes) basis, and erase command is executes on sector, or block, or whole chip.

To provide user with ease of interface, a status register is included to indicate the status of the chip. The status read command can be issued to detect completion status of a program or erase operation via WIP bit.

When the device is not in operation and CS# is high, it is put in Standby Mode and draws less than 30uA (typical:20uA) DC current.

The device utilizes Macronix proprietary memory cell, which reliably stores memory contents even after typical 100,000 program and erase cycles.

PIN CONFIGURATIONS

8-PIN SOP (150mil)

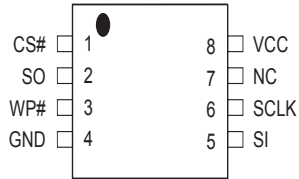

8-PIN TSSOP (173mil)

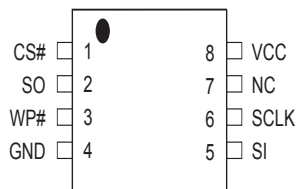

8-LAND USON (2x3mm)

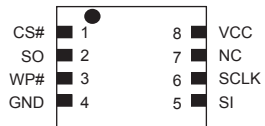

PIN DESCRIPTION

SYMBOL	DESCRIPTION
CS#	Chip Select
SI	Serial Data Input (for 1 x I/O)
SO	Serial Data Output (for 1 x I/O)
SCLK	Clock Input
NC	NC pin (Not connect)
WP#	Write Protection
VCC	2.7V to 3.6V Power Supply
GND	Ground

BLOCK DIAGRAM

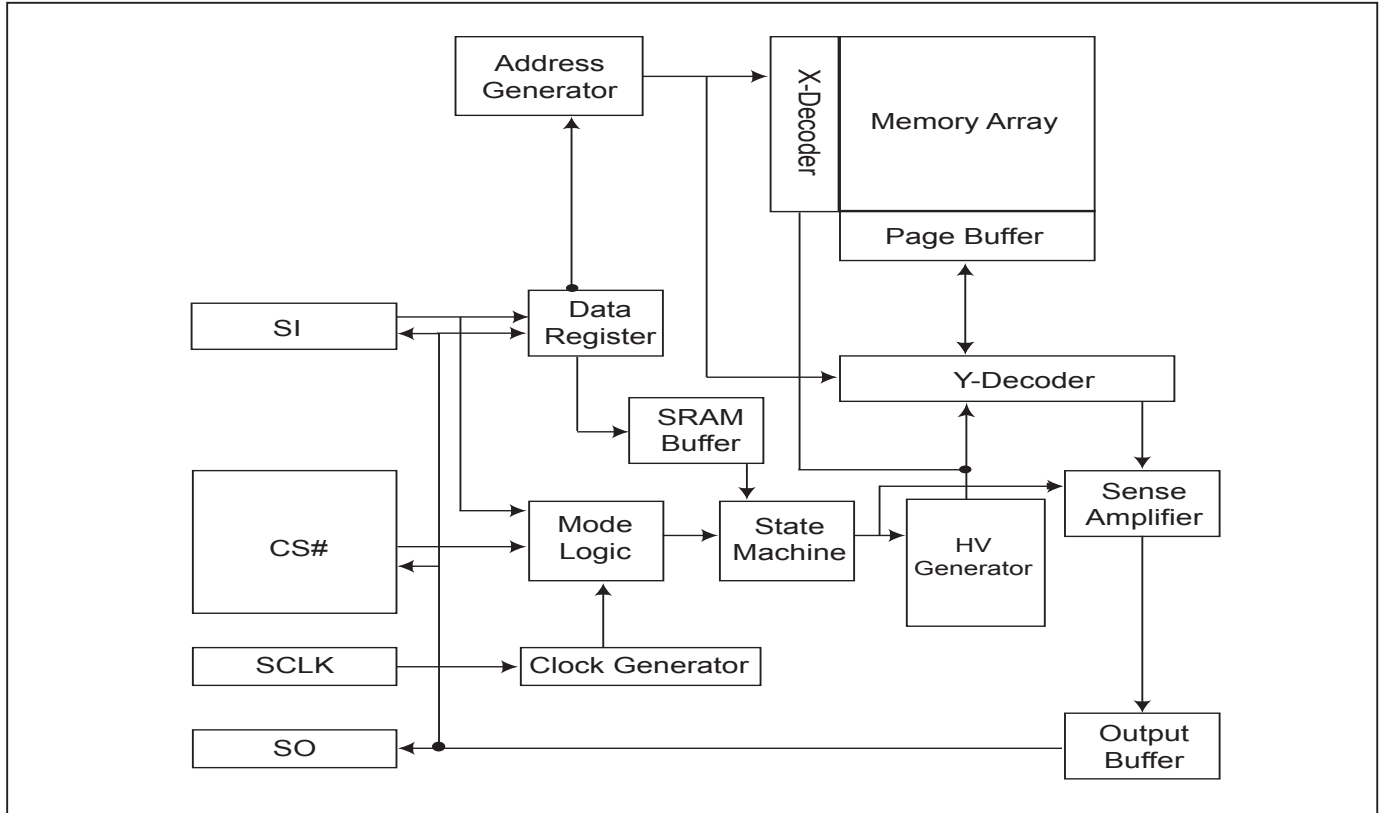

MEMORY ORGANIZATION**Table 1-1. Memory Organization (512Kb)**

Block	Sector	Address Range	
0	15	00F000h	00FFFFh
	:	:	:
	3	003000h	003FFFh
	2	002000h	002FFFh
	1	001000h	001FFFh
	0	000000h	000FFFh

Table 1-2. Memory Organization (1Mb)

Block	Sector	Address Range	
1	31	01F000h	01FFFFh
	:	:	:
	16	010000h	010FFFh
0	15	00F000h	00FFFFh
	:	:	:
	3	003000h	003FFFh
	2	002000h	002FFFh
	1	001000h	001FFFh
	0	000000h	000FFFh

DEVICE OPERATION

1. Before a command is issued, status register should be checked to ensure device is ready for the intended operation.
2. When incorrect command is inputted to this LSI, this LSI becomes Standby Mode and keeps the Standby Mode until next CS# falling edge. In Standby Mode, all SO pins of this LSI should be High-Z.
3. When correct command is inputted to this LSI, this LSI becomes active mode and keeps the active mode until next CS# rising edge.
4. Input data is latched on the rising edge of Serial Clock(SCLK) and data shifts out on the falling edge of SCLK. The difference of Serial mode 0 and mode 3 is shown as Figure 1.
5. For the following instructions: RDID, RDSR, READ and FAST_READ the shifted-in instruction sequence is followed by a data-out sequence. After any bit of data being shifted out, the CS# can be high. For the following instructions: WREN, WRDI, WRSR, SE, PP, RDP, and DP the CS# must go high exactly at the byte boundary; otherwise, the instruction will be rejected and not executed.
6. During the progress of Program, Erase operation, to access the memory array is neglected and not affect the current operation of Program and Erase.

Figure 1. Serial Modes Supported

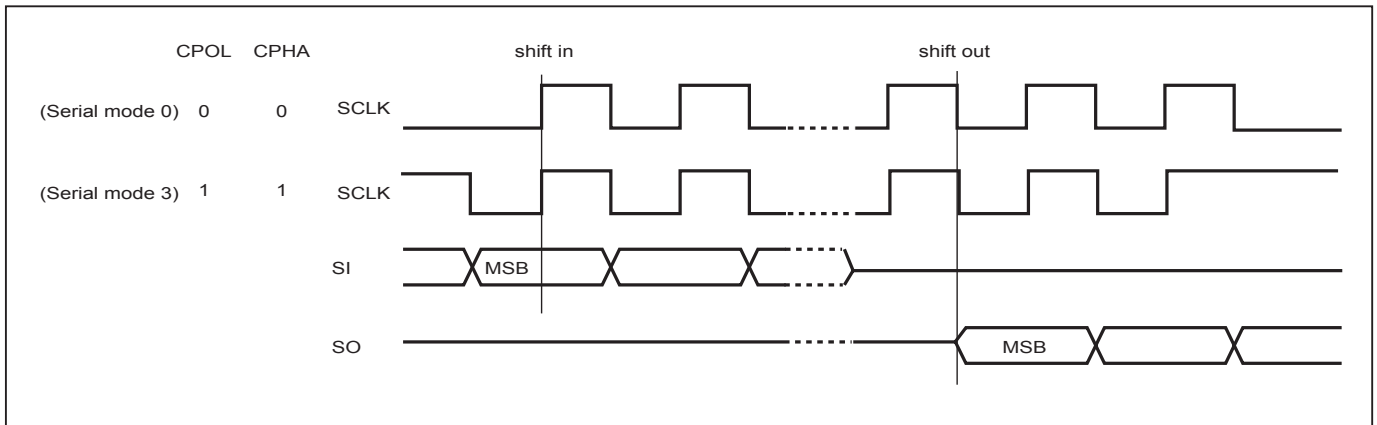

Note:

CPOL indicates clock polarity of Serial master, CPOL=1 for SCLK high while idle, CPOL=0 for SCLK low while not transmitting. CPHA indicates clock phase. The combination of CPOL bit and CPHA bit decides which Serial mode is supported.

DATA PROTECTION

The device is designed to offer protection against accidental erasure or programming caused by spurious system level signals that may exist during power transition. During power up the device automatically resets the state machine in the Standby Mode. In addition, with its control register architecture, alteration of the memory contents only occurs after successful completion of specific command sequences. The device also incorporates several features to prevent inadvertent write cycles resulting from VCC power-up and power-down transition or system noise.

- Valid command length checking: The command length will be checked whether it is at byte base and completed on byte boundary.
- Write Enable (WREN) command: WREN command is required to set the Write Enable Latch bit (WEL) before other command to change data. The WEL bit will return to reset stage under following situation:
 - Power-up
 - Write Disable (WRDI) command completion
 - Write Status Register (WRSR) command completion
 - Page Program (PP) command completion
 - Sector Erase (SE) command completion
 - Block Erase (BE) command completion
 - Chip Erase (CE) command completion
- Software Protection Mode (SPM): by using BP0-BP1 bits to set the part of Flash protected from data change.
- Hardware Protection Mode (HPM): by using WP# going low to protect the BP0-BP1 bits and SRWD bit from data change.
- Deep Power Down Mode: By entering Deep Power Down Mode, the flash device also is under protected from writing all commands except Release from Deep Power Down Mode command (RDP).

Table 2. Protected Area Sizes

Status bit		Protect level	
BP1	BP0	MX25L5121E	MX25L1021E
0	0	0 (none)	0 (none)
0	1	1 (All)	1 (1 block)
1	0	2 (All)	2 (All)
1	1	3 (All)	3 (All)

COMMAND DESCRIPTION

Table 3. Command Set

Command (byte)	WREN (write enable)	WRDI (write disable)	WRSR (write status register)	RDID (read identification)	RDSR (read status register)	READ (read data)	FAST READ (fast read data)
1st byte	06 (hex)	04 (hex)	01 (hex)	9F (hex)	05 (hex)	03 (hex)	0B (hex)
2nd byte						AD1 (A23-A16)	AD1
3rd byte						AD2 (A15-A8)	AD2
4th byte						AD3 (A7-A0)	AD3
5th byte							Dummy
Action	sets the (WEL) write enable latch bit	resets the (WEL) write enable latch bit	to write new values of the status register	outputs JEDEC ID: 1-byte Manufacturer ID & 2-bytes Device ID	to read out the values of the status register	n bytes read out until CS# goes high	n bytes read out until CS# goes high

Command (byte)	SE (sector erase)	BE (block erase)	CE (chip erase)	PP (page program)	DP (Deep power down)	RDP (Release from deep power down)
1st byte	20 (hex)	52 or D8 (hex)	60 or C7 (hex)	02 (hex)	B9 (hex)	AB (hex)
2nd byte	AD1	AD1		AD1		
3rd byte	AD2	AD2		AD2		
4th byte	AD3	AD3		AD3		
Action	to erase the selected sector	to erase the selected block	to erase whole chip	to program the selected page	enters Deep Power Down Mode	release from Deep Power Down Mode

Note 1: It is not recommended to adopt any other code not in the command definition table, which will potentially enter the hidden mode.

Note 2: Value "1" should be input to the un-used significant bits of address bits by user (e.g. A17~A23(MSB) in MX25L1021E ; A16-A23(MSB) in MX25L5121E)

(1) Write Enable (WREN)

The Write Enable (WREN) instruction is for setting Write Enable Latch (WEL) bit. For those instructions like PP, SE, BE, CE and WRSR which are intended to change the device content, should be set every time after the WREN instruction setting the WEL bit.

The sequence of issuing WREN instruction is: CS# goes low→ sending WREN instruction code→CS# goes high. (Please refer to [Figure 9](#))

(2) Write Disable (WRDI)

The Write Disable (WRDI) instruction is for resetting Write Enable Latch (WEL) bit.

The sequence of issuing WRDI instruction is: CS# goes low→sending WRDI instruction code→CS# goes high. (Please refer to [Figure 10](#))

The WEL bit is reset by following situations:

- Power-up
- Write Disable (WRDI) instruction completion
- Write Status Register (WRSR) instruction completion
- Page Program (PP) instruction completion
- Sector Erase (SE) instruction completion
- Block Erase (BE) instruction completion
- Chip Erase (CE) instruction completion

(3) Read Identification (RDID)

The RDID instruction is for reading the manufacturer ID of 1-byte and followed by Device ID of 2-bytes. The MXIC Manufacturer ID is C2(hex), the memory type ID is 22(hex) as the first-byte device ID, and the individual device ID of second-byte ID are listed as table of "ID Definitions". (Please refer to table 4)

The sequence of issuing RDID instruction is: CS# goes low→sending RDID instruction code→24-bits ID data out on SO→ to end RDID operation can use CS# to high at any time during data out. (Please refer to [Figure 11](#))

While Program/Erase operation is in progress, it will not decode the RDID instruction, so there's no effect on the cycle of program/erase operation which is currently in progress. When CS# goes high, the device is at Standby Mode.

Table 4. ID Definitions

RDID Command	MX25L5121E			MX25L1021E		
	manufacturer ID	memory type	memory density	manufacturer ID	memory type	memory density
	C2	22	10	C2	22	11

(4) Read Status Register (RDSR)

The RDSR instruction is for reading Status Register Bits. The Read Status Register can be read at any time (even in program/erase condition) and continuously. It is recommended to check the Write in Progress (WIP) bit before sending a new instruction when a program or erase operation is in progress.

The sequence of issuing RDSR instruction is: CS# goes low→sending RDSR instruction code→Status Register data out on SO (Please refer to [Figure 12-1](#), [Figure 12-2](#))

The definition of the status register bits is as below:

WIP bit. The Write in Progress (WIP) bit, a volatile bit, indicates whether the device is busy in program/erase progress. When WIP bit sets to 1, which means the device is busy in program/erase progress. When WIP bit sets to 0, which means the device is not in progress of program/erase register cycle.

WEL bit. The Write Enable Latch (WEL) bit, a volatile bit, indicates whether the device is set to internal write enable latch. When WEL bit sets to 1, which means the internal write enable latch is set, the device can accept program/erase instruction. When WEL bit sets to 0, which means no internal write enable latch; the device will not accept program/erase instruction.

BP1, BP0 bits. The Block Protect (BP1, BP0) bits, volatile bits, indicate the protected area(as defined in table 1) of the device to against the program/erase instruction without hardware protection mode being set. To write the Block Protect (BP1, BP0) bits requires the Write Status Register (WRSR) instruction to be executed. Those bits define the protected area of the memory to against Page Program (PP), Sector Erase (SE), Block Erase (BE) and Chip Erase(CE) instructions (only if all Block Protect bits set to 0, the CE instruction can be executed)

SRWD bit. The Status Register Write Disable (SRWD) bit, volatile bit, is operated together with Write Protection (WP#) pin for providing hardware protection mode. The hardware protection mode requires SRWD sets to 1 and WP# pin signal is low stage. In the hardware protection mode, the Write Status Register (WRSR) instruction is no longer accepted for execution and the SRWD bit and Block Protect bits (BP1, BP0) are read only.

Table 5. Status Register

bit7	bit6	bit5	bit4	bit3	bit2	bit1	bit0
SRWD (status register write protect)	Reserved	Reserved	Reserved	BP1 (level of protected block)	BP0 (level of protected block)	WEL (write enable latch)	WIP (write in progress bit)
1=status register write disable	0	0	0	(note 1)	(note 1)	1=write enable 0=not write enable	1=write operation 0=not in write operation

Note: 1. See the table "Protected Area Sizes". The default BP0-BP2 values are "1" (protected).
2. The SRWD default value is "0"

(5) Write Status Register (WRSR)

The WRSR instruction is for changing the values of Status Register Bits. Before sending WRSR instruction, the Write Enable (WREN) instruction must be decoded and executed to set the Write Enable Latch (WEL) bit in advance. The WRSR instruction can change the value of Block Protect (BP1, BP0) bits to define the protected area of memory (as shown in table 1). The WRSR also can set or reset the Status Register Write Disable (SRWD) bit in accordance with Write Protection (WP#) pin signal. The WRSR instruction cannot be executed once the Hardware Protected Mode (HPM) is entered.

The sequence of issuing WRSR instruction is: CS# goes low → sending WRSR instruction code → Status Register data on SI → CS# goes high. (see [Figure 13](#))

The WRSR instruction has no effect on b6, b5, b4, b1, b0 of the status register.

The CS# must go high exactly at the byte boundary; otherwise, the instruction will be rejected and not executed. The self-timed Write Status Register cycle time (tW) is initiated as soon as Chip Select (CS#) goes high. The Write in Progress (WIP) bit still can be check out during the Write Status Register cycle is in progress. The WIP sets 1 during the tW timing, and sets 0 when Write Status Register Cycle is completed, and the Write Enable Latch (WEL) bit is reset.

Table 6. Protection Modes

Mode	Status register condition	WP# and SRWD bit status	Memory
Software protection mode (SPM)	Status register can be written in (WEL bit is set to "1") and the SRWD, BP0-BP1 bits can be changed	WP#=1 and SRWD bit=0, or WP#=0 and SRWD bit=0, or WP#=1 and SRWD=1	The protected area cannot be program or erase.
Hardware protection mode (HPM)	The SRWD, BP0-BP1 of status register bits cannot be changed	WP#=0, SRWD bit=1	The protected area cannot be program or erase.

Note:

1. As defined by the values in the Block Protect (BP1, BP0) bits of the Status Register, as shown in Table 1.

As the table above showing, the summary of the Software Protected Mode (SPM) and Hardware Protected Mode (HPM).

Software Protected Mode (SPM):

- When SRWD bit=0, no matter WP# is low or high, the WREN instruction may set the WEL bit and can change the values of SRWD, BP1, BP0. The protected area, which is defined by BP1, BP0, is at software protected mode (SPM).
- When SRWD bit=1 and WP# is high, the WREN instruction may set the WEL bit can change the values of SRWD, BP1, BP0. The protected area, which is defined by BP1, BP0, is at software protected mode (SPM)

Note: If SRWD bit=1 but WP# is low, it is impossible to write the Status Register even if the WEL bit has previously been set. It is rejected to write the Status Register and not be executed.

Hardware Protected Mode (HPM):

- When SRWD bit=1, and then WP# is low (or WP# is low before SRWD bit=1), it enters the hardware protected mode (HPM). The data of the protected area is protected by software protected mode by BP1, BP0 and hardware protected mode by the WP# to against data modification.

Note: to exit the hardware protected mode requires WP# driving high once the hardware protected mode is entered. If the WP# pin is permanently connected to high, the hardware protected mode can never be entered; only can use software protected mode via BP1, BP0.

(6) Read Data Bytes (READ)

The read instruction is for reading data out. The address is latched on rising edge of SCLK, and data shifts out on the falling edge of SCLK at a maximum frequency f_C . The first address can be at any location. The address is automatically increased to the next higher address after each byte data is shifted out, so the whole memory can be read out at a single READ instruction.

This product does not provide the function of read around. After reading through density 512Kb or 1Mb, CS# must go high. Otherwise, the data correctness will not be guaranteed. If the device needs to read data again, it must issue read command once more.

The sequence of issuing READ instruction is: CS# goes low→ sending READ instruction code→ 3-bytes address on SI→data out on SO→to end READ operation can use CS# to high at any time during data out. (Please refer to [Figure 14](#))

(7) Read Data Bytes at Higher Speed (FAST_READ)

The FAST_READ instruction is for quickly reading data out. The address is latched on rising edge of SCLK, and data of each bit shifts out on the falling edge of SCLK at a maximum frequency f_C . The first address byte can be at any location. The address is automatically increased to the next higher address after each byte data is shifted out, so the whole memory can be read out at a single FAST_READ instruction. The address counter rolls over to 0 when the highest address has been reached.

The sequence of issuing FAST_READ instruction is: CS# goes low→ sending FAST_READ instruction code→ 3-byte address on SI→ 1-dummy byte address on SI→data out on SO→ to end FAST_READ operation can use CS# to high at any time during data out. (Please refer to [Figure 15](#))

While Program/Erase/Write Status Register cycle is in progress, FAST_READ instruction is rejected without any impact on the Program/Erase/Write Status Register current cycle.

(8) Sector Erase (SE)

The Sector Erase (SE) instruction is for erasing the data of the chosen sector to be "1". The instruction is used for any 4K-bytes sector. A Write Enable (WREN) instruction must execute to set the Write Enable Latch (WEL) bit before sending the Sector Erase (SE). Any address of the sector (Please refer to table 1) is a valid address for Sector Erase (SE) instruction. The CS# must go high exactly at the byte boundary (the eighth bit of last address byte been latched-in); otherwise, the instruction will be rejected and not executed.

Address bits [Am-A12] (Am is the most significant address) select the sector address.

The sequence of issuing SE instruction is: CS# goes low→sending SE instruction code→3-bytes address on SI→CS# goes high. (Please refer to [Figure 16](#))

The self-timed Sector Erase Cycle time (t_{SE}) is initiated as soon as Chip Select (CS#) goes high. The Write in Progress (WIP) bit still can be check out during the Sector Erase cycle is in progress. The WIP sets 1 during the t_{SE} timing, and sets 0 when Sector Erase Cycle is completed, and the Write Enable Latch (WEL) bit is reset.

(9) Block Erase (BE)

The Block Erase (BE) instruction is for erasing the data of the chosen block to be "1". The instruction is used for 64K-byte sector erase operation. A Write Enable (WREN) instruction must execute to set the Write Enable Latch (WEL)

bit before sending the Block Erase (BE). Any address of the block (see table 2) is a valid address for Block Erase (BE) instruction. The CS# must go high exactly at the byte boundary (the latest eighth of address byte been latched-in); otherwise, the instruction will be rejected and not executed.

The sequence is shown as [Figure 17](#).

The self-timed Block Erase Cycle time (tBE) is initiated as soon as Chip Select (CS#) goes high. The Write in Progress (WIP) bit still can be check out during the Sector Erase cycle is in progress. The WIP sets 1 during the tBE timing, and sets 0 when Sector Erase Cycle is completed, and the Write Enable Latch (WEL) bit is reset.

(10) Chip Erase (CE)

The Chip Erase (CE) instruction is for erasing the data of the whole chip to be "1". A Write Enable (WREN) instruction must execute to set the Write Enable Latch (WEL) bit before sending the Chip Erase (CE). Any address of the sector (see table 1) is a valid address for Chip Erase (CE) instruction. The CS# must go high exactly at the byte boundary(the latest eighth of address byte been latched-in); otherwise, the instruction will be rejected and not executed.

The sequence is shown as [Figure 18](#).

The self-timed Chip Erase Cycle time (tCE) is initiated as soon as Chip Select (CS#) goes high. The Write in Progress (WIP) bit still can be check out during the Chip Erase cycle is in progress. The WIP sets 1 during the tCE timing, and sets 0 when Chip Erase Cycle is completed, and the Write Enable Latch (WEL) bit is reset.

(11) Page Program (PP)

The Page Program (PP) instruction is for programming the memory to be "0". A Write Enable (WREN) instruction must execute to set the Write Enable Latch (WEL) bit before sending the Page Program (PP). After the instruction and address input, data to be programmed is input sequentially. The internal sequence controller will sequentially program the data from the initial address. If the transmitted data goes beyond the page boundary, the internal sequence controller may not function properly and the content of the device will not be guaranteed. Therefore, If the initial A4-A0 (The five least significant address bits) are set to all 0, maximum 32 bytes of data can be input sequentially. If the initial address A4-A0 (The five least significant address bits) are not set to all 0, maximum bytes of data input will be the subtraction of the initial address A4-A0 from 32bytes. The data exceeding 32bytes data is not sent to device. In this case, data is not guaranteed.

The sequence of issuing PP instruction is: CS# goes low → sending PP instruction code → 3-bytes address on SI → at least 1-byte on data on SI → CS# goes high. (Please refer to [Figure 19](#))

The CS# must be kept to low during the whole Page Program cycle; The CS# must go high exactly at the byte boundary(the eighth bit of data being latched in), otherwise the instruction will be rejected and will not be executed.

The self-timed Page Program Cycle time (tPP) is initiated as soon as Chip Select (CS#) goes high. The Write in Progress (WIP) bit still can be check out during the Page Program cycle is in progress. The WIP sets 1 during the tPP timing, and sets 0 when Page Program Cycle is completed, and the Write Enable Latch (WEL) bit is reset.

(12) Deep Power-Down (DP)

The Deep Power Down (DP) instruction is for setting the device on the minimizing the power consumption (to entering the Deep Power Down Mode), the standby current is reduced from ISB1 to ISB2. The Deep Power Down Mode requires the Deep Power Down (DP) instruction to enter, during the Deep Power Down Mode, the device is not ac-

tive and all Read/Write/Program/Erase instruction are ignored.

The sequence of issuing DP instruction is: CS# goes low→sending DP instruction code→ CS# goes high. (Please refer to [Figure 20](#))

Once the DP instruction is set, all instruction will be ignored except the Release from Deep Power Down Mode (RDP) instruction. When Power-down, the Deep Power Down Mode automatically stops, and when power-up, the device automatically is in Standby Mode. For RDP instruction the CS# must go high exactly at the byte boundary (the latest eighth bit of instruction code been latched-in); otherwise, the instruction will not executed. As soon as Chip Select (CS#) goes high, a delay of tDP is required before entering the Deep Power Down Mode.

(13) Release from Deep Power-Down (RDP)

The Release from Deep Power Down (RDP) instruction is terminated by driving Chip Select (CS#) High. When Chip Select (CS#) is driven High, the device is put in the Standby Mode. If the device was not previously in the Deep Power Down Mode, the transition to the Standby Mode is immediate. If the device was previously in the Deep Power Down Mode, though, the transition to the Standby Mode is delayed by tRES1, and Chip Select (CS#) must remain High for at least tRES1(max), as specified in [Table 8](#). AC Characteristics. Once in the Standby Mode, the device waits to be selected, so that it can receive, decode and execute instructions. The RDP instruction is only for releasing from Deep Power Down Mode.

The sequence is shown as [Figure 21](#). Even in Deep Power Down Mode, the RDP is also allowed to be executed, only except the device is in progress of program/erase cycle; there's no effect on the current program/erase cycle in progress.

POWER-ON STATE

The device is at below states when power-up:

- Standby Mode (please note it is not Deep Power Down Mode)
- Write Enable Latch (WEL) bit is reset

The device must not be selected during power-up and power-down stage unless the VCC achieves below correct level:

- VCC minimum at power-up stage and then after a delay of tVSL
- GND at power-down

Please note that a pull-up resistor on CS# may ensure a safe and proper power-up/down level.

An internal power-on reset (POR) circuit may protect the device from data corruption and inadvertent data change during power up state.

For further protection on the device, if the VCC does not reach the VCC minimum level, the correct operation is not guaranteed. The read, write, erase, and program command should be sent after the below time delay:

- tVSL after VCC reached VCC minimum level

Note:

- To stabilize the VCC level, the VCC rail decoupled by a suitable capacitor close to package pins is recommended. (generally around 0.1uF)

Program/ Erase flow with read array data

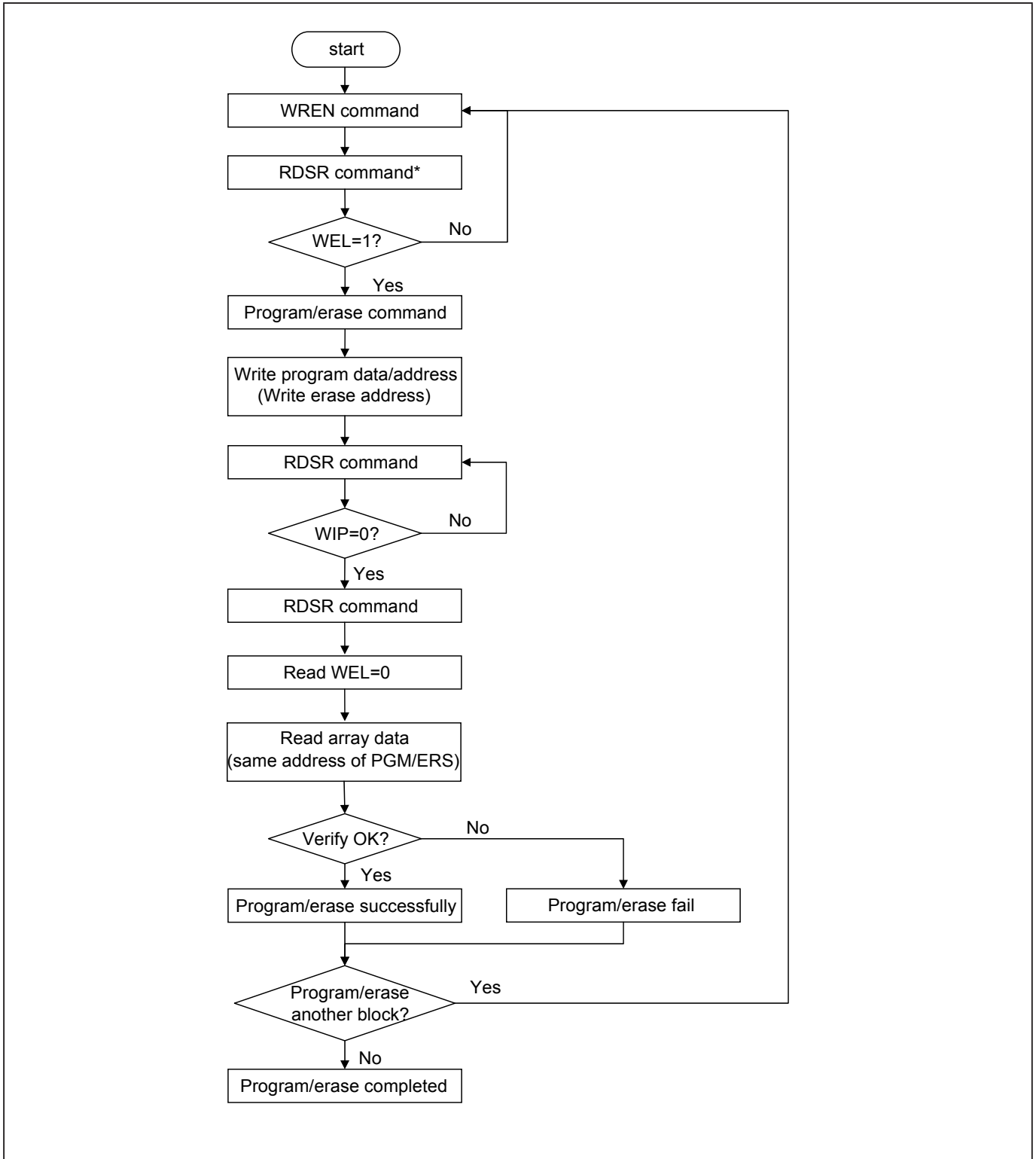

ELECTRICAL SPECIFICATIONS

ABSOLUTE MAXIMUM RATINGS

RATING		VALUE
Ambient Operating Temperature	Commercial grade	0°C to 70°C
Storage Temperature		-65°C to 150°C
Applied Input Voltage		-0.5V to 4.6V
Applied Output Voltage		-0.5V to 4.6V
VCC to Ground Potential		-0.5V to 4.6V

Notes:

1. Stresses greater than those listed under ABSOLUTE MAXIMUM RATINGS may cause permanent damage to the device. This is stress rating only and functional operational sections of this specification is not implied. Exposure to absolute maximum rating conditions for extended period may affect reliability.
2. Specifications contained within the following tables are subject to change.
3. During voltage transitions, all pins may overshoot Vss to -2.0V and Vcc to +2.0V for periods up to 20ns, please refer to Figure 2, 3.

Figure 2. Maximum Negative Overshoot Waveform

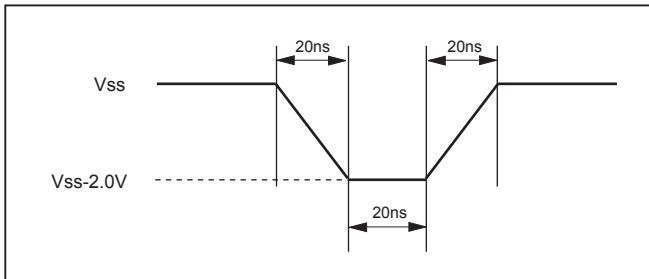
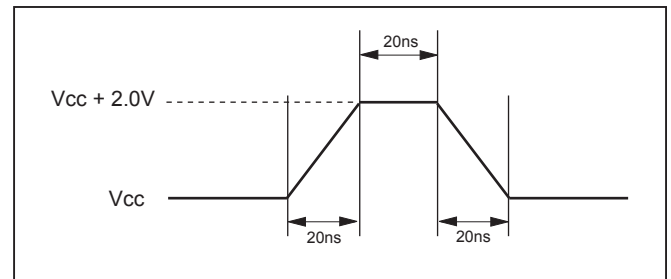

Figure 3. Maximum Positive Overshoot Waveform



CAPACITANCE TA = 25°C, f = 1.0 MHz

Symbol	Parameter	Min.	Typ.	Max.	Unit	Conditions
CIN	Input Capacitance			6	pF	VIN = 0V
COU	Output Capacitance			8	pF	VOU = 0V

Figure 4. INPUT TEST WAVEFORMS AND MEASUREMENT LEVEL

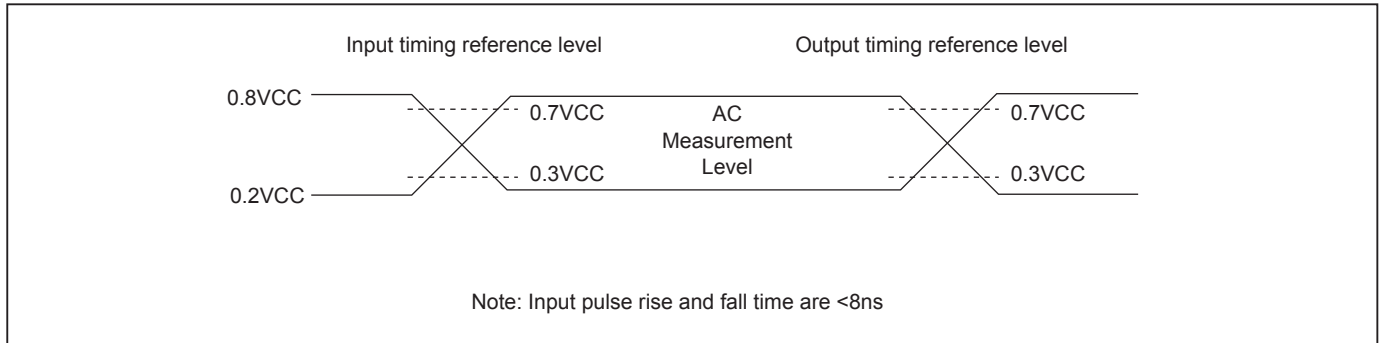

Notes: Rise time means 0.2VCC to 0.8VCC; Fall time means 0.8VCC to 0.2VCC.

Figure 5. OUTPUT LOADING

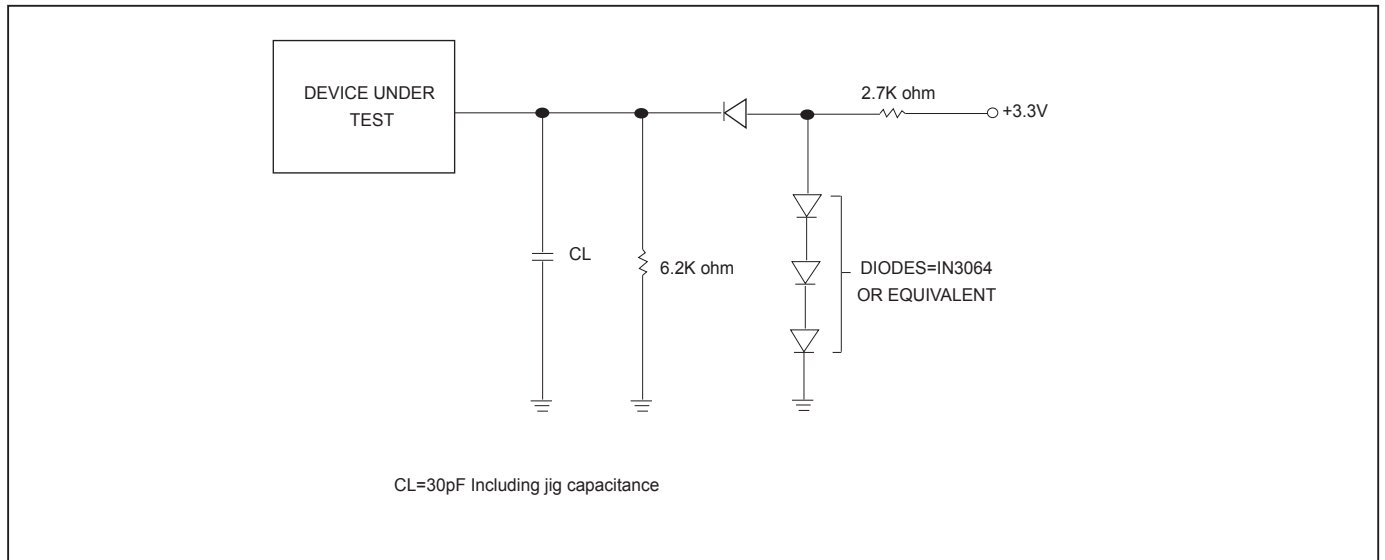

Table 7. DC CHARACTERISTICS (Temperature = 0°C to 70°C for Commercial grade, VCC = 2.7V ~ 3.6V)

Symbol	Parameter	Notes	Min.	Typ.	Max.	Units	Test Conditions
ILI	Input Load Current	1			± 2	uA	VCC = VCC Max, VIN = VCC or GND
ILO	Output Leakage Current	1			± 2	uA	VCC = VCC Max, VOUT = VCC or GND
ISB1	VCC Standby Current	1		20	30	uA	VIN = VCC or GND, CS# = VCC
ISB2	Deep Power Down Current			2	8	uA	VIN = VCC or GND, CS# = VCC
ICC1	VCC Read	1			10	mA	f=45MHz, SCLK=0.1VCC/0.9VCC, SO=Open
					5	mA	f=25MHz, SCLK=0.1VCC/0.9VCC, SO=Open
ICC2	VCC Program Current (PP)	1			12	mA	Program in Progress, CS# = VCC
ICC3	VCC Write Register (WRSR) Current	1			15	mA	Program Status Register in Progress, CS#=VCC
ICC4	VCC Sector Erase Current (SE)	1			15	mA	Erase in Progress, CS#=VCC
VIL	Input Low Voltage		-0.5		0.2VCC	V	
VIH	Input High Voltage		0.8VCC		VCC+0.4	V	
VOL	Output Low Voltage				0.4	V	IOL = 1.6mA
VOH	Output High Voltage		VCC-0.2			V	IOH = -100uA
VWI	Low VCC Write Inhibit Voltage	3	2.1	2.3	2.5	V	

Notes :

1. Typical values at VCC = 3.3V, T = 25°C. These currents are valid for all product versions (package and speeds).
2. Typical value is calculated by simulation.
3. Not 100% tested.

Table 8. AC CHARACTERISTICS (Temperature = 0°C to 70°C for Commercial grade, VCC = 2.7V ~ 3.6V)

Symbol	Alt.	Parameter	Min.	Typ.	Max.	Unit	
fSCLK	fC	Clock Frequency for FAST_READ	1KHz		45	MHz	
fRSCLK	fR	Clock Frequency for the following instructions: READ, PP, SE, BE, CE, DP, RDP, WREN, RDID, RDSR, WRSR	1KHz		25	MHz	
tCH(1)	tCLH	Clock High Time	@ 25 MHz	18		ns	
			@ 45 MHz	10		ns	
tCL(1)	tCLL	Clock Low Time	@ 25 MHz	18		ns	
			@ 45 MHz	10		ns	
tCLCH(2)		Clock Rise Time (3) (peak to peak)	0.1			V/ns	
tRISE(2)		Clock Rise Time (3)			10	ns/V	
tCHCL(2)		Clock Fall Time (3) (peak to peak)	0.1			V/ns	
tFALL(2)		Clock Fall Time (3)			10	ns/V	
tSLCH	tCSS	CS# Active Setup Time (relative to SCLK)	20			ns	
tCHSL		CS# Not Active Hold Time (relative to SCLK)	20			ns	
tDVCH	tDSU	Data In Setup Time	4			ns	
tCHDX	tDH	Data In Hold Time	6			ns	
tCHSH		CS# Active Hold Time (relative to SCLK)	20			ns	
tSHCH		CS# Not Active Setup Time (relative to SCLK)	20			ns	
tSHSL(3)	tCSH	CS# Deselect Time	Read	50		ns	
			Write/Erase/Program	50		ns	
tSHQZ(2)	tDIS	Output Disable Time			20	ns	
tCLQV	tV	Clock Low to Output Valid	@ 25 MHz		18	ns	
			@ 45 MHz		18	ns	
tCLQX	tHO	Output Hold Time	0			ns	
tWHSL(4)		Write Protect Setup Time	20			ns	
tSHWL(4)		Write Protect Hold Time	100			ns	
tW		Write Status Register Cycle Time		5	15	ms	
tDP(2)		CS# High to Deep Power Down Mode			20	us	
tRES1(2)		CS# High to Standby Mode without Electronic Signature Read			20	us	
tPP		Page Program Cycle Time (32 Bytes)		180	650	us	
tSE		Sector Erase Cycle Time (4K Bytes)		90	300	ms	
tRPD1		CS# High to Power-Down	100			ns	
tBE		Block Erase Cycle Time		1	2	s	
tCE		Chip Erase Cycle Time	512Kb		1	2	s
			1Mb		1.5	3	s

Notes:

1. tCH + tCL must be greater than or equal to 1/ f (fC).
2. Value guaranteed by characterization, not 100% tested in production.
3. Test condition is shown as Figure 4, 5.
4. Only applicable as a constraint for a WRSR instruction when SRWD is set at 1.

Timing Analysis

Figure 6. Serial Input Timing

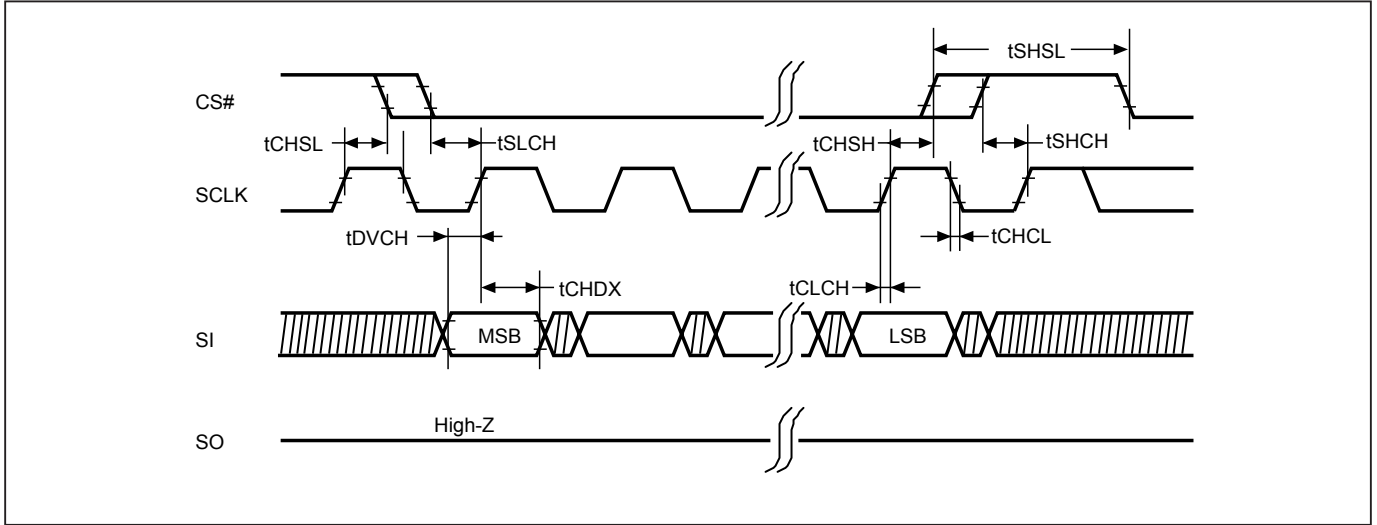

Figure 7. Output Timing

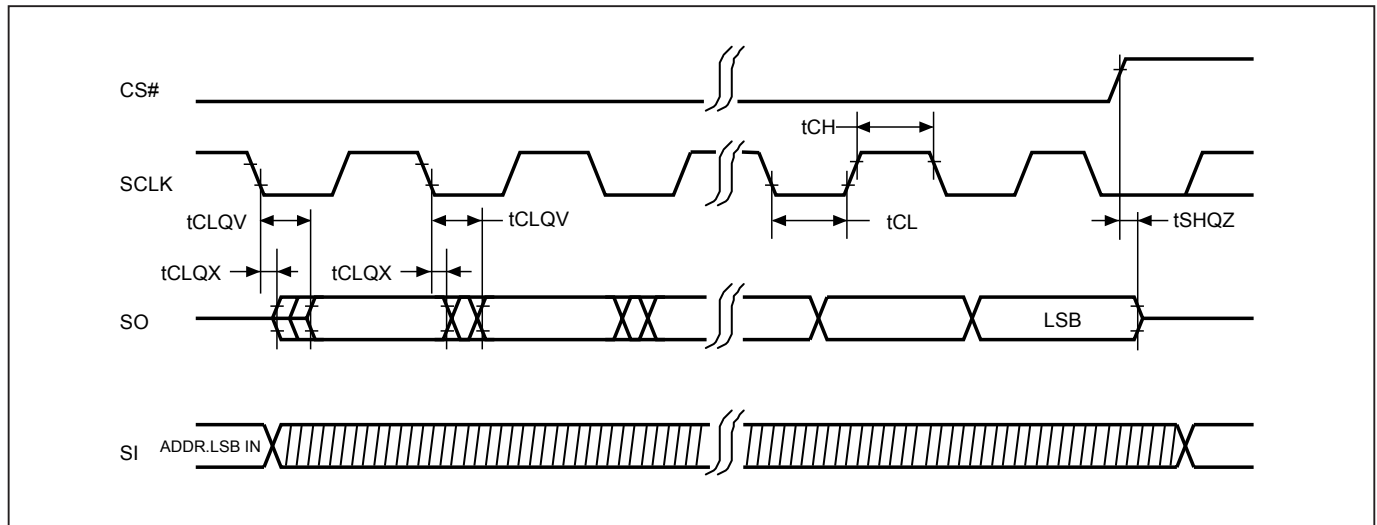

Figure 8. WP# Disable Setup and Hold Timing during WRSR when SRWD=1

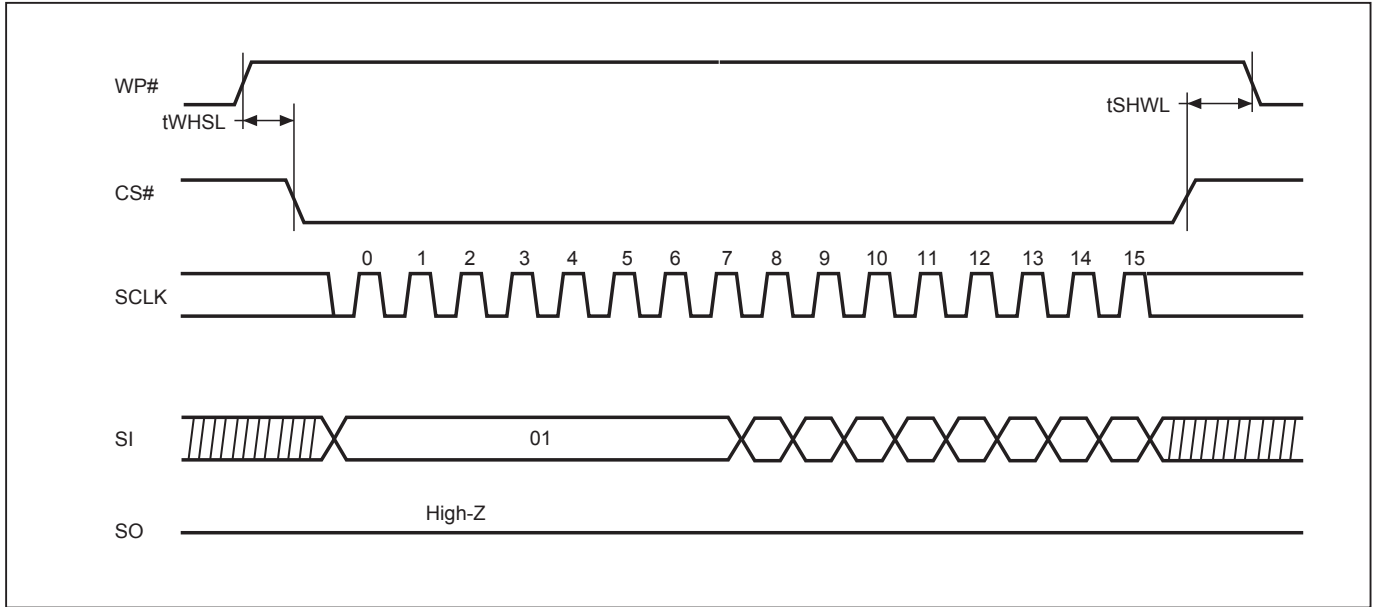

Figure 9. Write Enable (WREN) Sequence (Command 06)

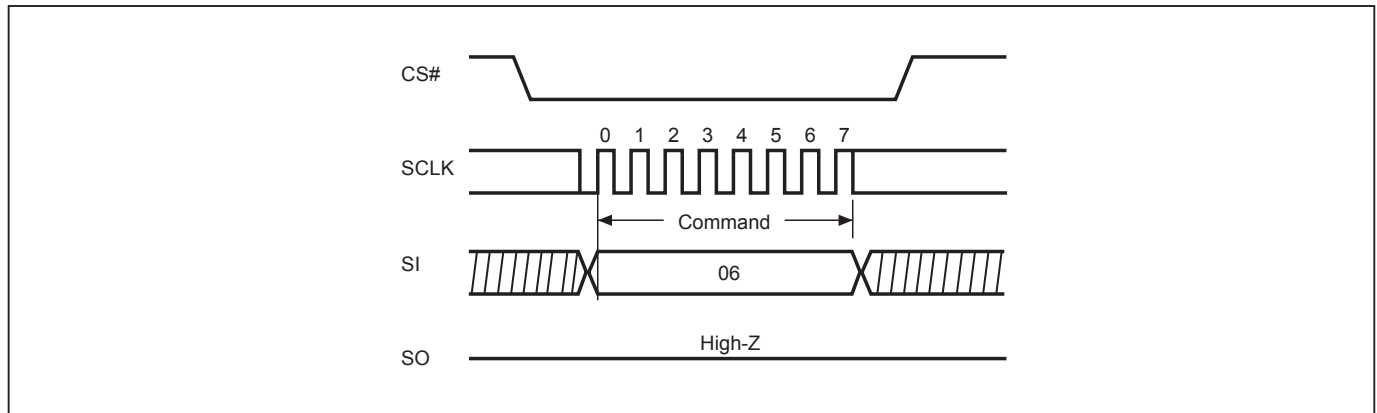

Figure 10. Write Disable (WRDI) Sequence (Command 04)

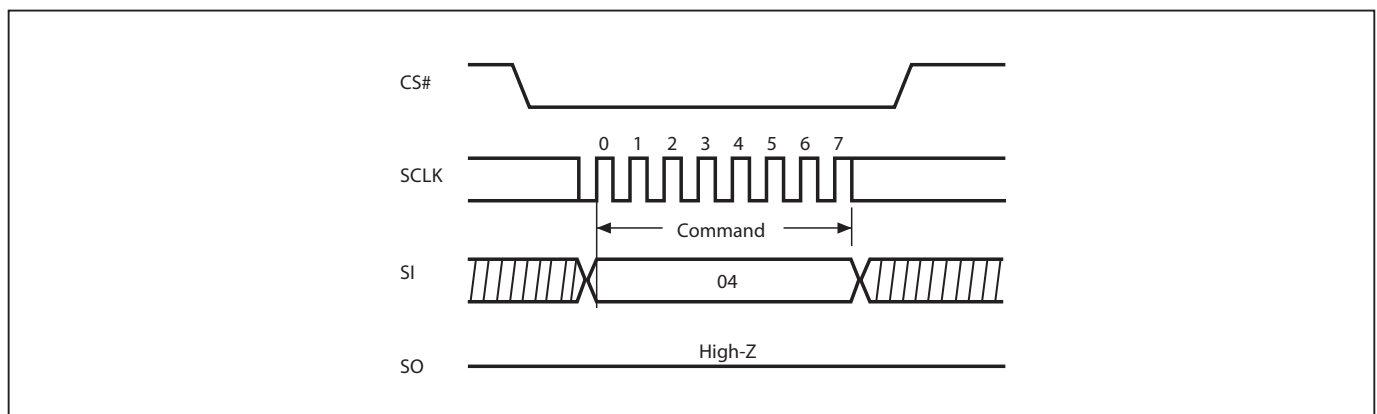

Figure 11. Read Identification (RDID) Sequence (Command 9F)

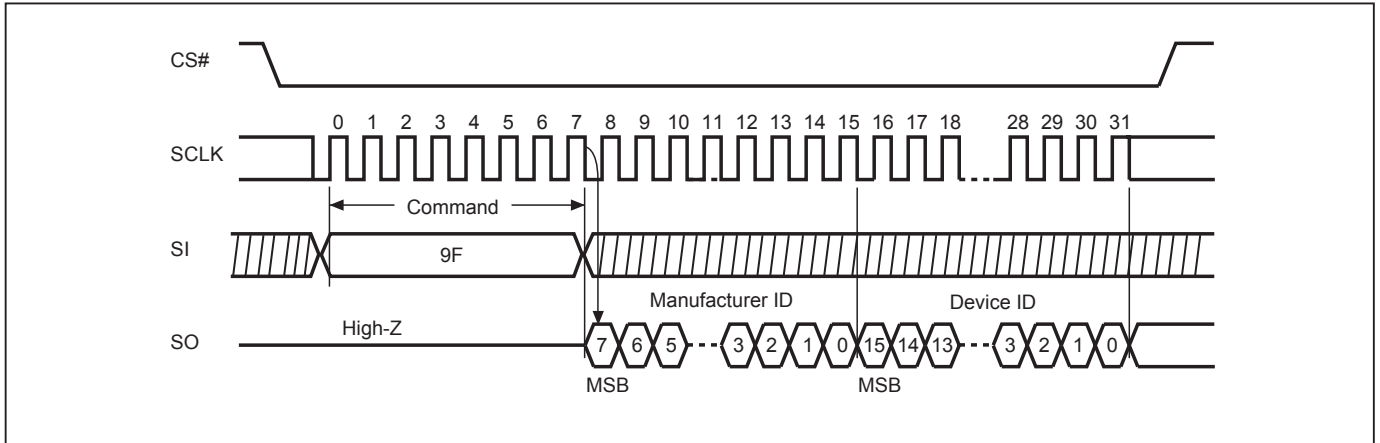

Figure 12-1. Read Status Register (RDSR) Sequence (Command 05)

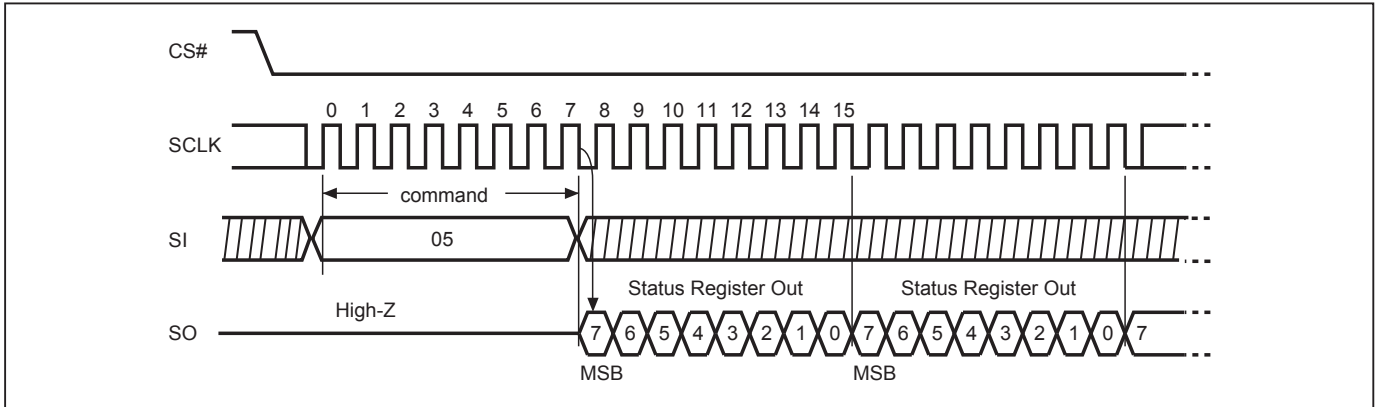

Figure 12-2. Read Status Register (RDSR) Sequence (Command 05)

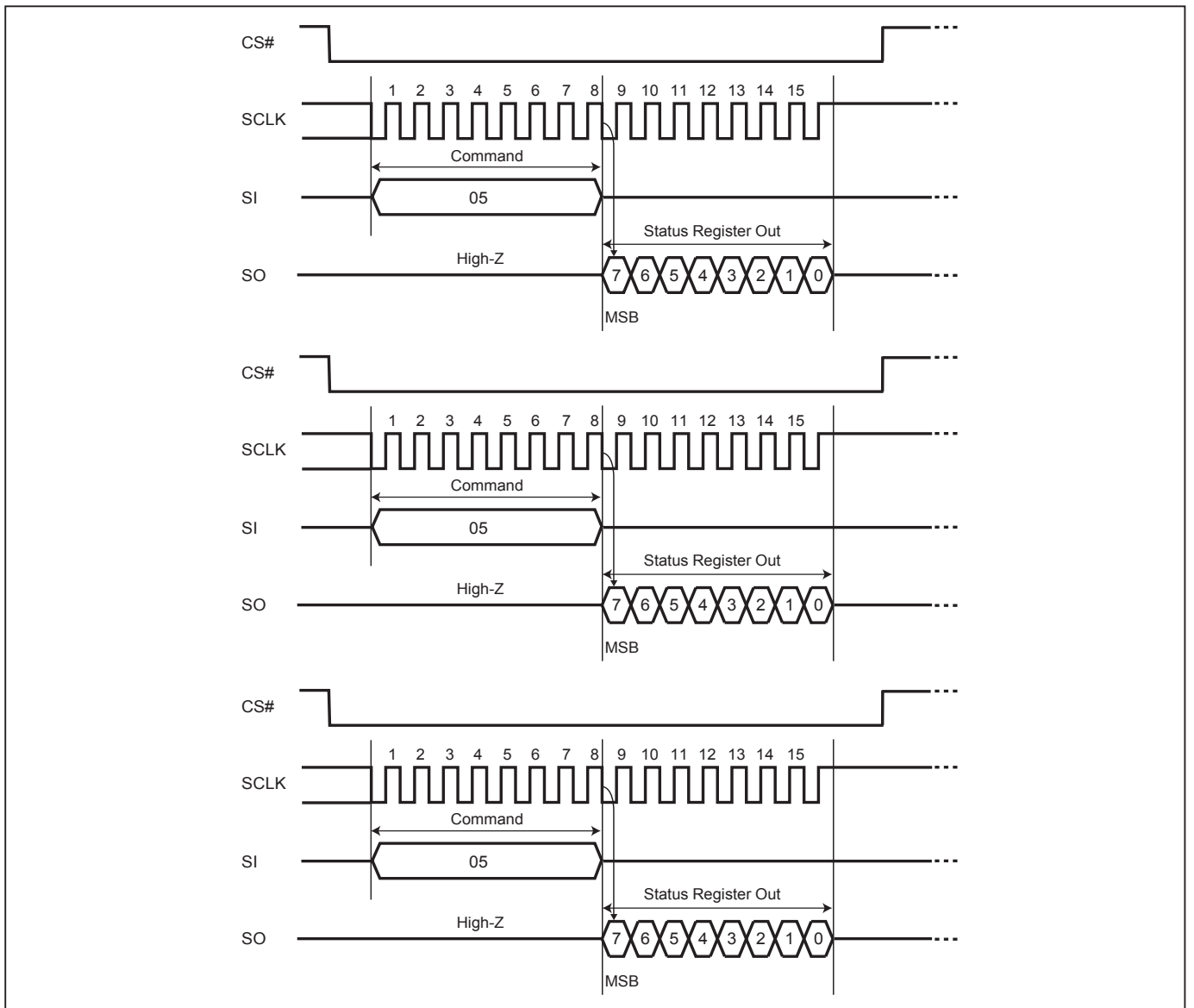

Figure 13. Write Status Register (WRSR) Sequence (Command 01)

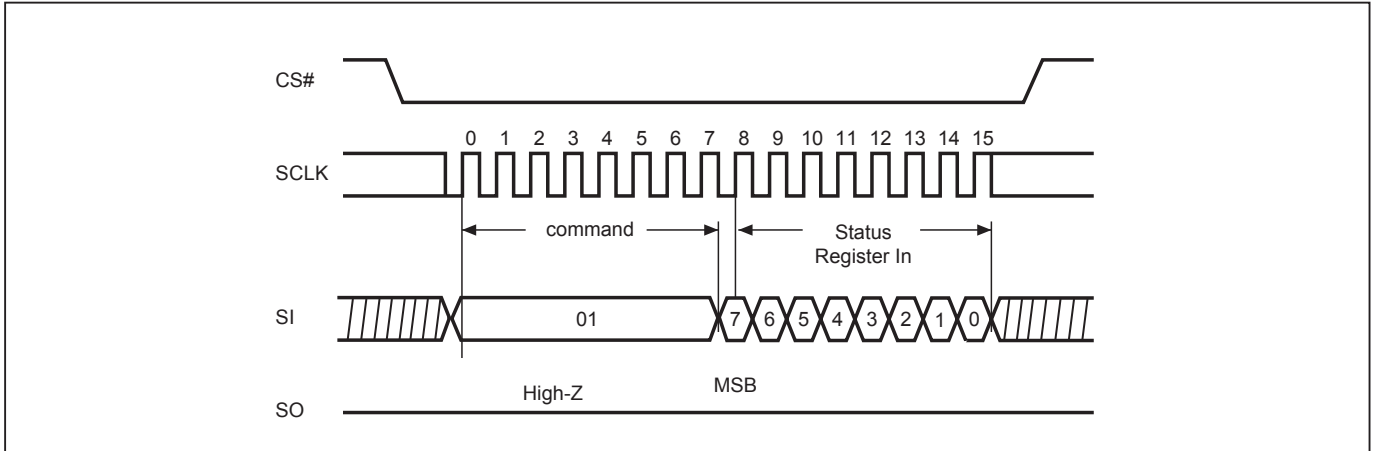

Figure 14. Read Data Bytes (READ) Sequence (Command 03)

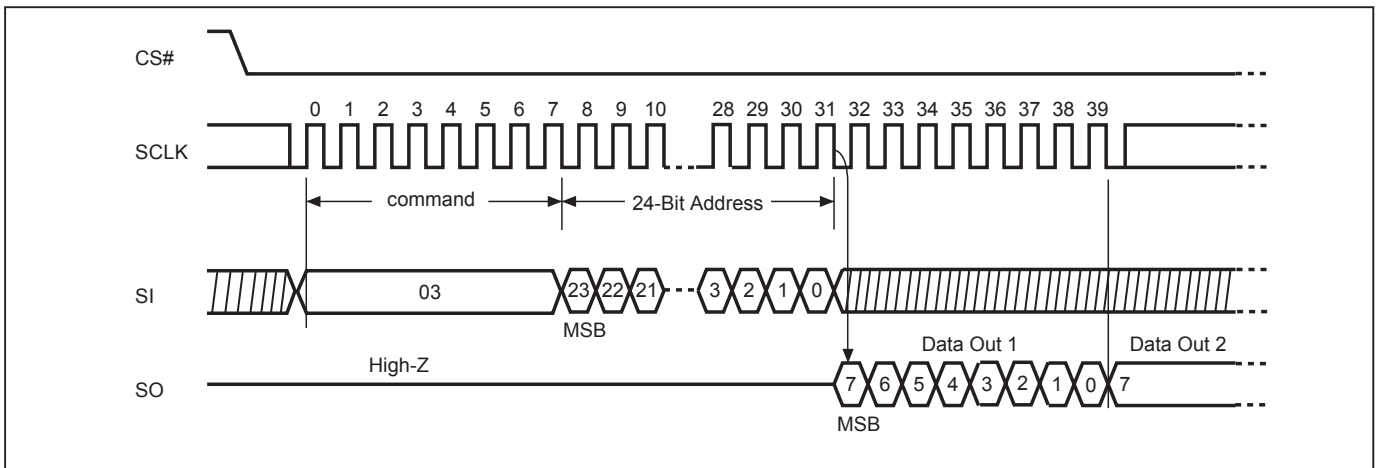

Figure 15. Read at Higher Speed (FAST_READ) Sequence (Command 0B)

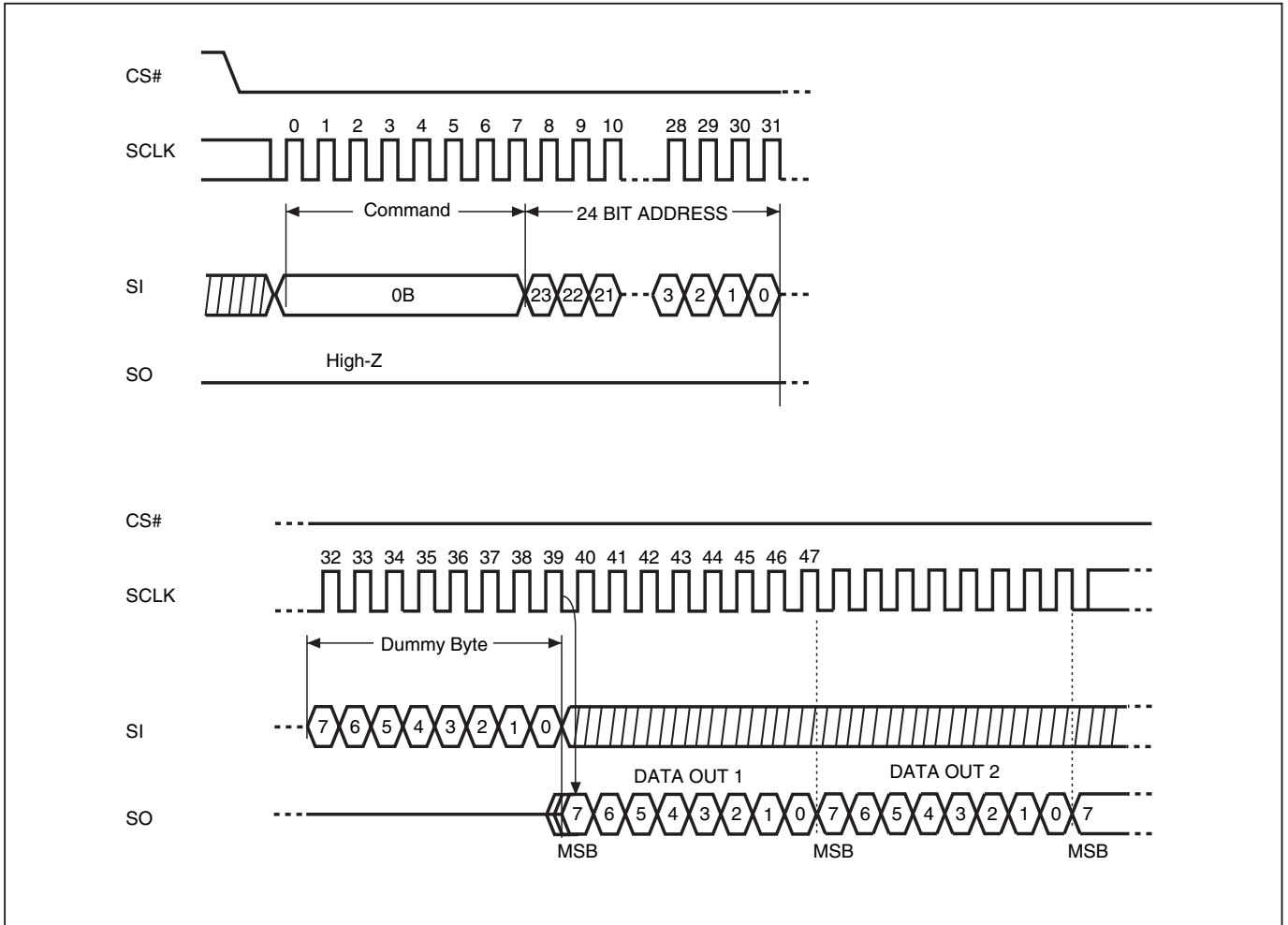

Figure 16. Sector Erase (SE) Sequence (Command 20)

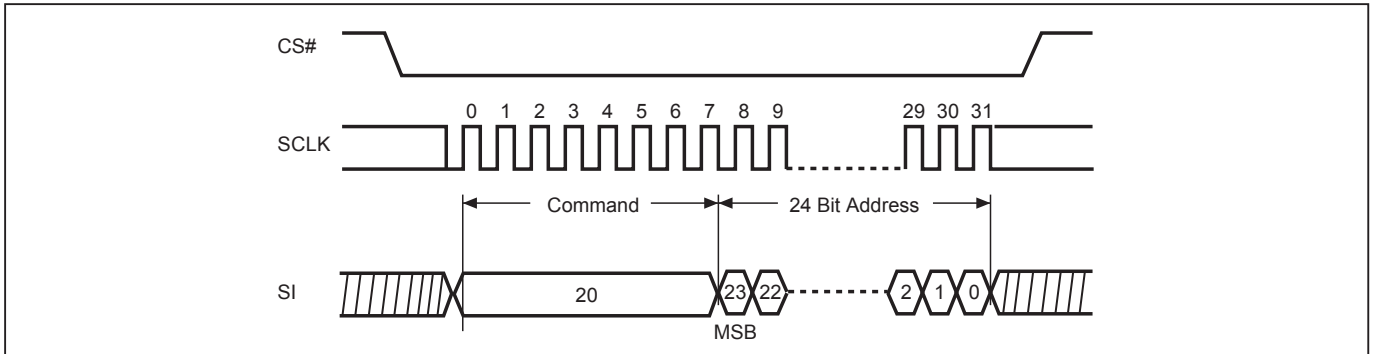
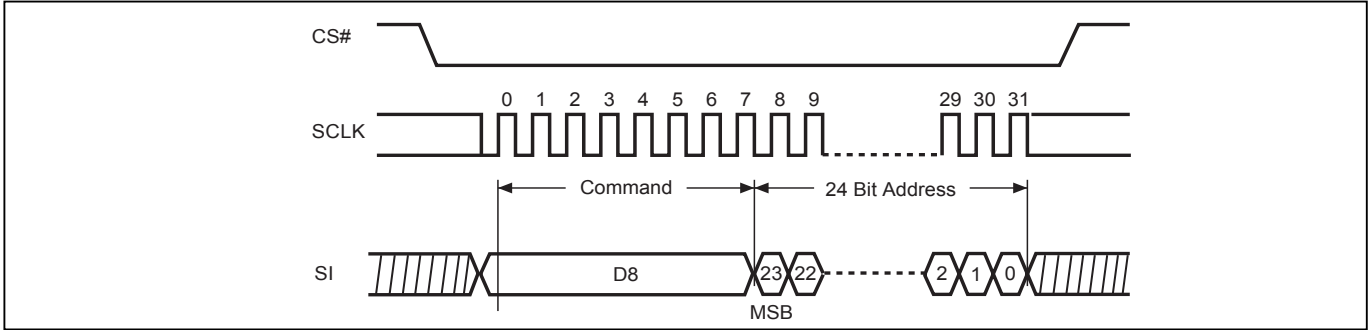
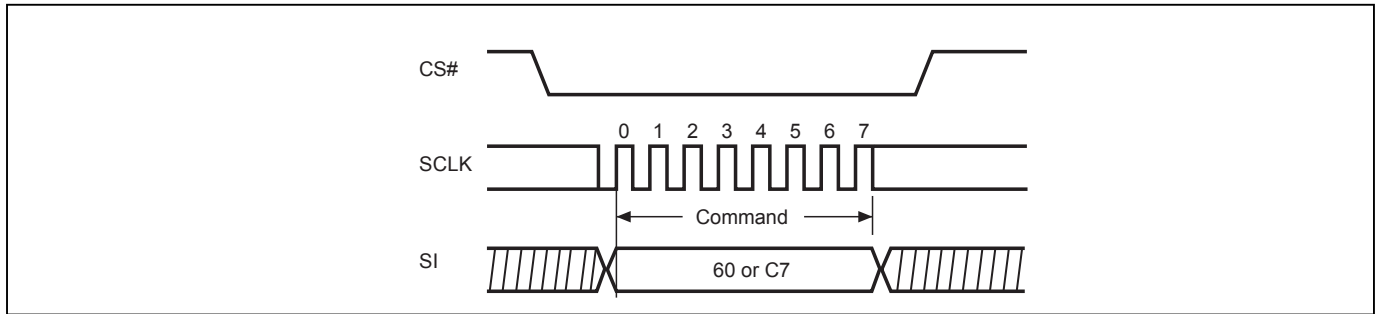

Figure 17. Block Erase (BE) Sequence (Command D8 or 52)



Note: BE command is D8(hex).

Figure 18. Chip Erase (CE) Sequence (Command 60 or C7)



Note: CE command is 60(hex) or C7(hex).

Figure 19. Page Program (PP) Sequence (Command 02)

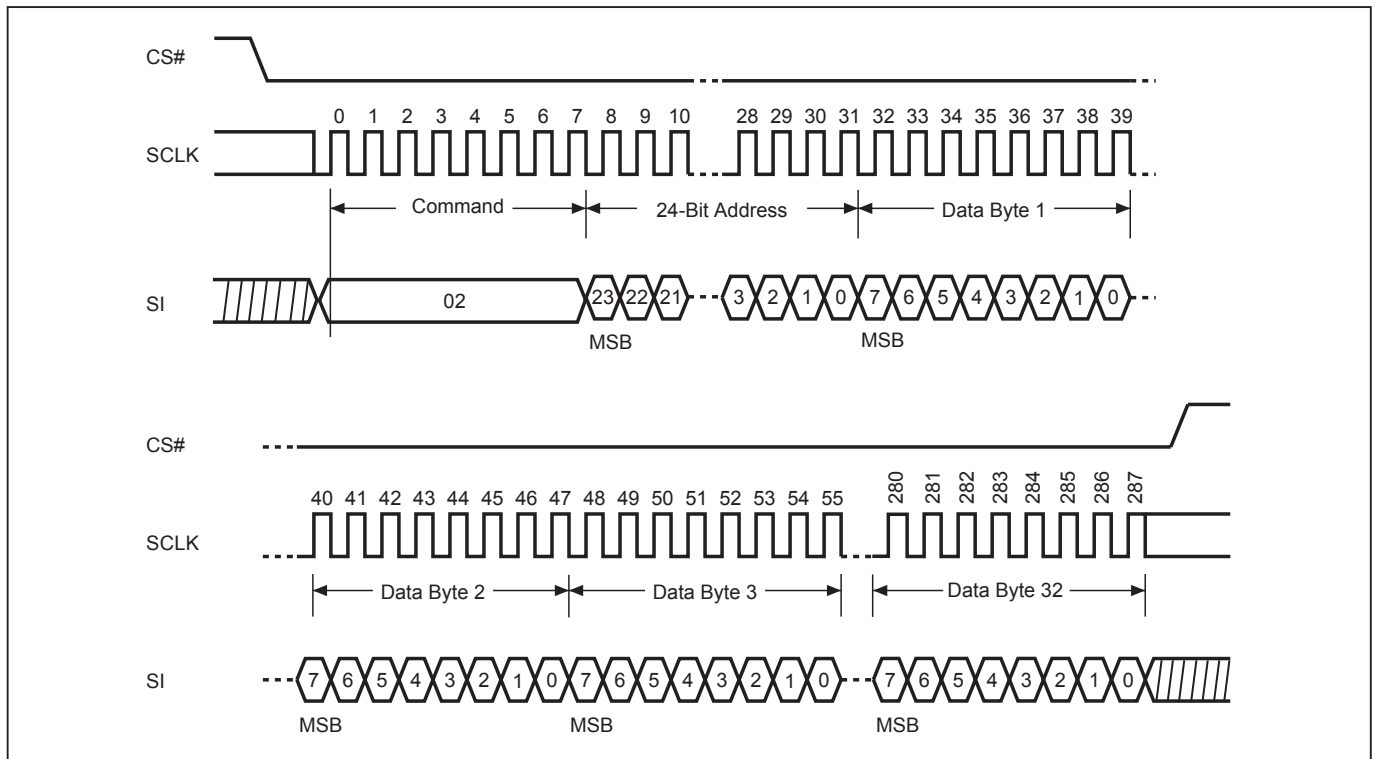

Figure 20. Deep Power Down (DP) Sequence (Command B9)**Figure 21. Release from Deep Power Down (RDP) Sequence (Command AB)**

Figure 23. Power-Up Timing

Note: VCC (max.) is 3.6V and VCC (min.) is 3.0V.

Table 9. Power-Up Timing

Symbol	Parameter	Min.	Max.	Unit
tVSL(1)	VCC(min) to CS# low	300		us

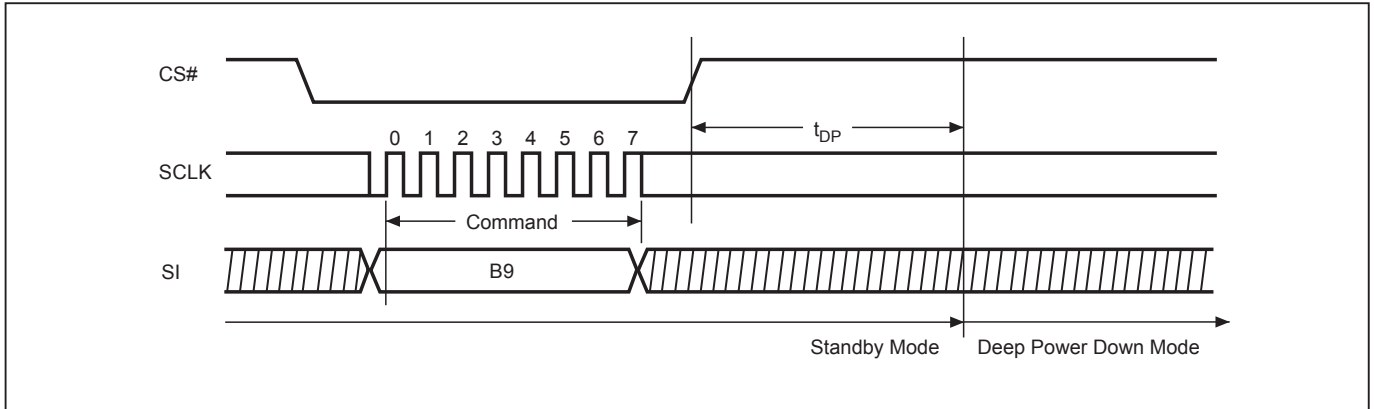
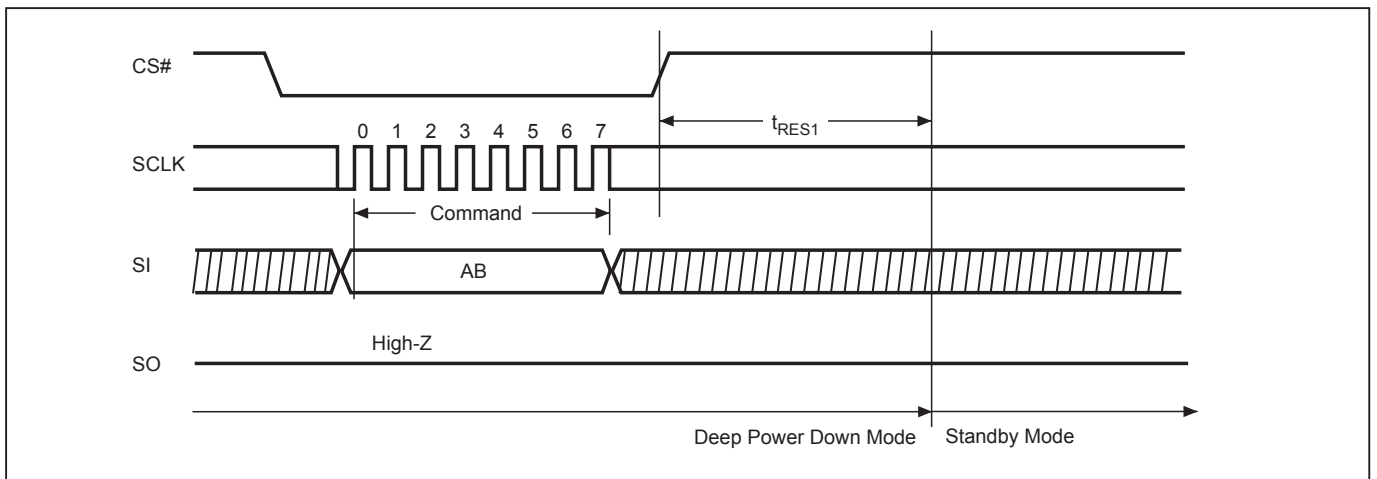
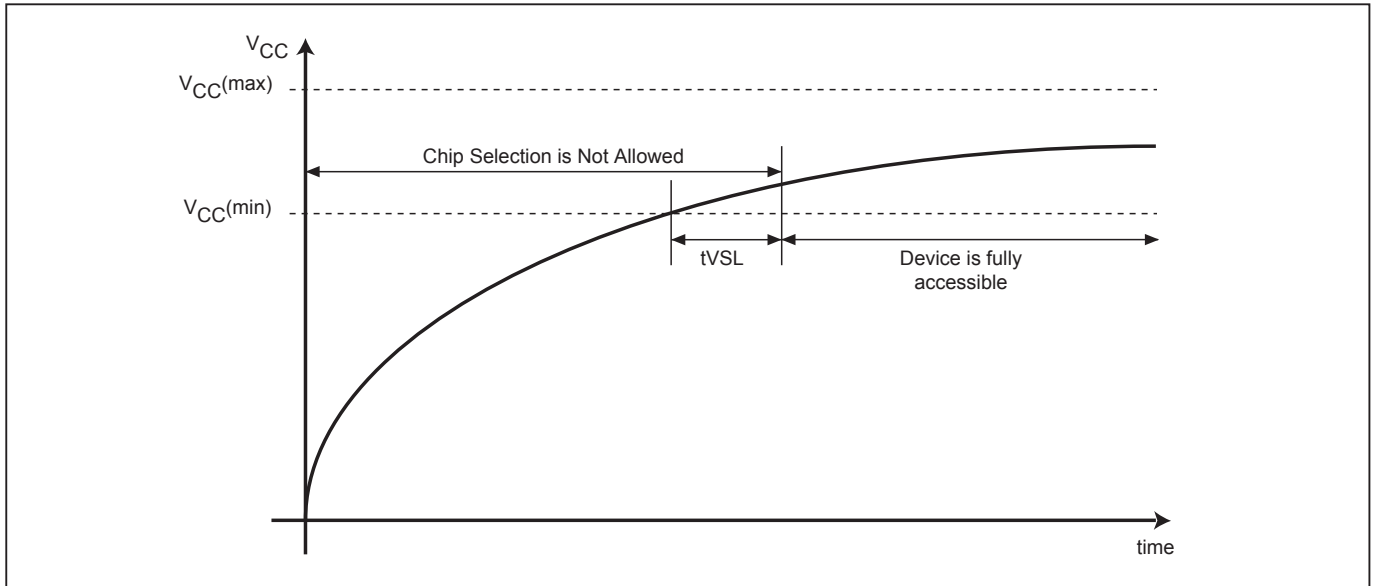
Note: 1. The parameter is characterized only.

INITIAL DELIVERY STATE

The device is delivered with the memory array erased: all bits are set to 1 (each byte contains FFh). The Status Register contains 00h (all Status Register bits are 0).

OPERATING CONDITIONS

At Device Power-Up and Power-Down

AC timing illustrated in Figure 24 and Figure 25 are for the supply voltages and the control signals at device power-up and power-down. If the timing in the figures is ignored, the device will not operate correctly.

During power-up and power-down, CS# needs to follow the voltage applied on VCC to keep the device not to be selected. The CS# can be driven low when VCC reach $V_{CC}(\min.)$ and wait a period of t_{VSL} .

Figure 24. AC Timing at Device Power-Up

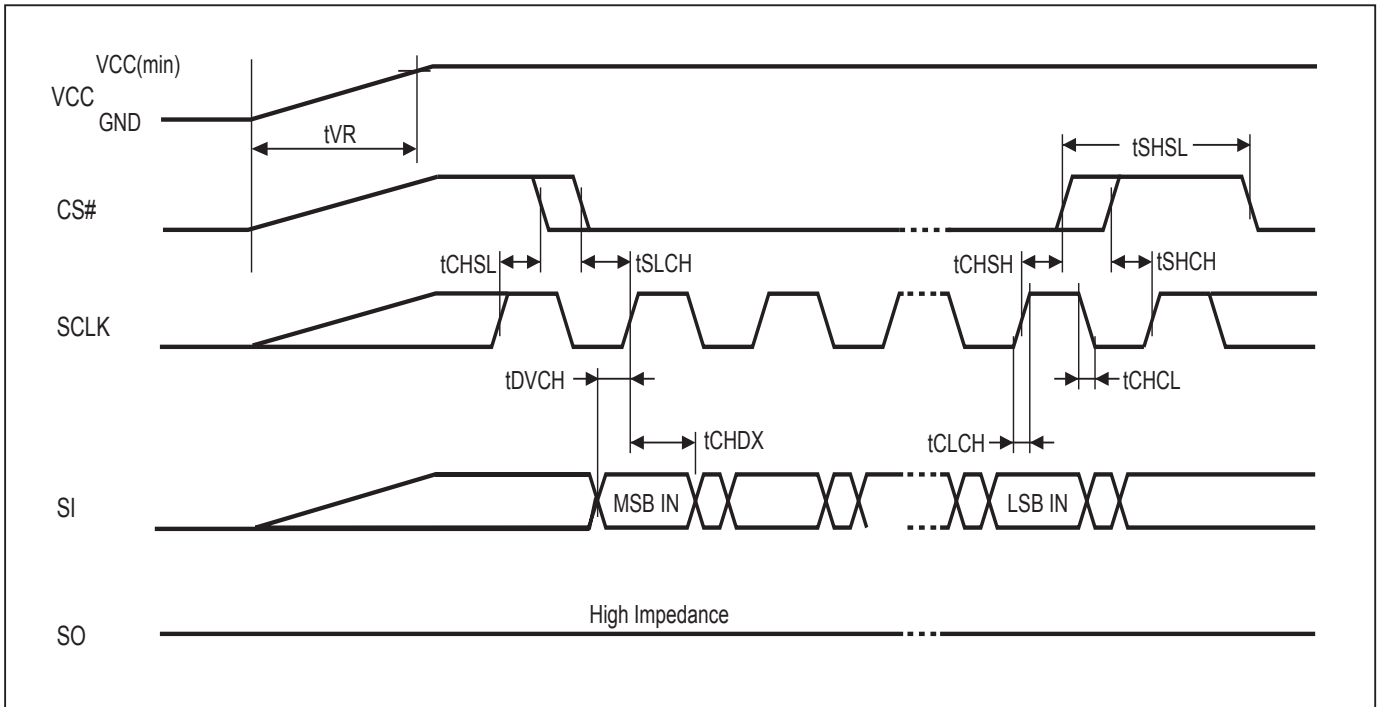

Symbol	Parameter	Notes	Min.	Max.	Unit
t_{VR}	VCC Rise Time	1	10	500000	us/V
t_{RH}	Reset High Time Before Read		5		ms

Notes :

1. Sampled, not 100% tested.
2. For AC spec t_{SLCH} , t_{DVCH} , t_{CHDX} , t_{CHSH} in the figure, please refer to "AC CHARACTERISTICS" table.

ERASE AND PROGRAMMING PERFORMANCE

Parameter		Min.	Typ. (1)	Max. (2)	Unit
Sector Erase Time			90	300	ms
Block Erase Time			1	2	s
Chip Erase Time	512Kb		1	2	s
	1Mb		1.5	3	s
Page Program Time			180	650	us
Erase/Program Cycle			100,000		cycles

Note:

1. Typical program and erase time assumes the following conditions: 25°C, 3.3V, and checker board pattern.
2. Under worst conditions of 70°C and 2.7V.
3. System-level overhead is the time required to execute the first-bus-cycle sequence for the programming command.
4. Erase/Program cycles comply with JEDEC JESD-47E & A117A standard.

DATA RETENTION

Parameter	Condition	Min.	Max.	Unit
Data retention	70°C	20		years

LATCH-UP CHARACTERISTICS

	Min.	Max.
Input Voltage with respect to GND on all power pins, SI, CS#	-1.0V	2 VCCmax
Input Voltage with respect to GND on SO	-1.0V	VCC + 1.0V
Current	-100mA	+100mA
Includes all pins except VCC. Test conditions: VCC = 3.0V, one pin at a time.		

ORDERING INFORMATION**512Kb**

PART NO.	CLOCK (MHz)	TEMPERATURE	PACKAGE	Remark
MX25L5121EMC-20G	45	0°C~70°C	8-SOP (150mil)	
MX25L5121EOC-20G	45	0°C~70°C	8-TSSOP (173mil)	
MX25L5121EZUC-20G	45	0°C~70°C	8-USON (2x3mm)	

1Mb

PART NO.	CLOCK (MHz)	TEMPERATURE	PACKAGE	Remark
MX25L1021EMC-20G	45	0°C~70°C	8-SOP (150mil)	

PART NAME DESCRIPTION

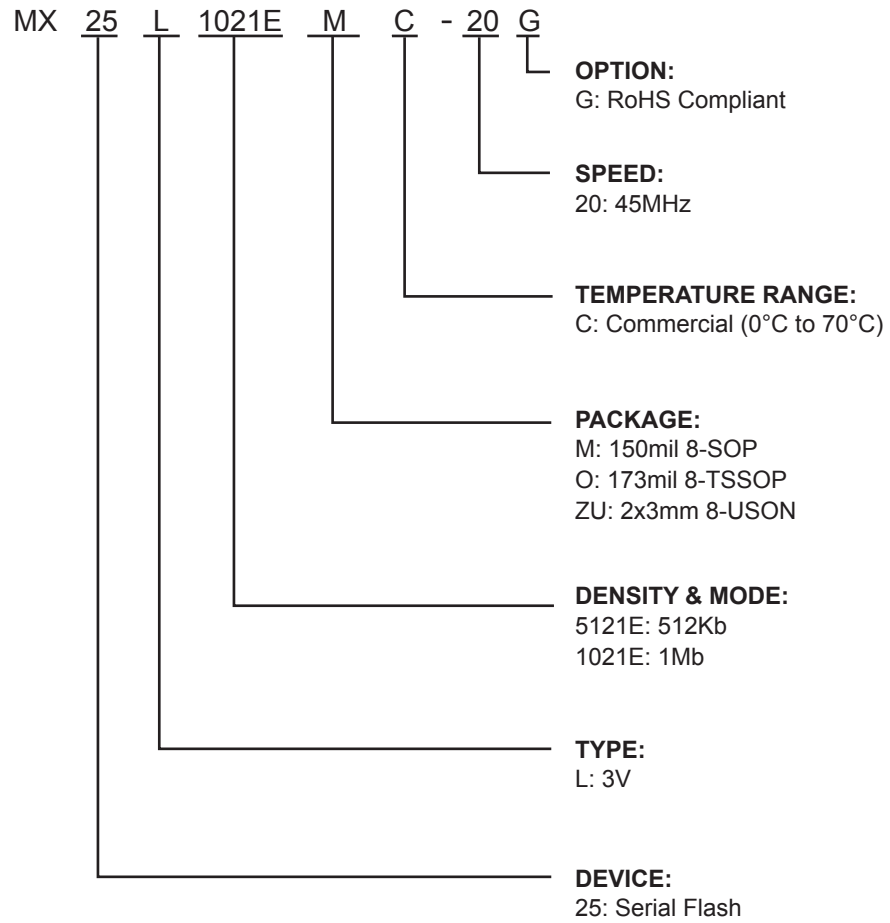

PACKAGE INFORMATION

Doe. Title: Package Outline for SOP 8L (150MIL)

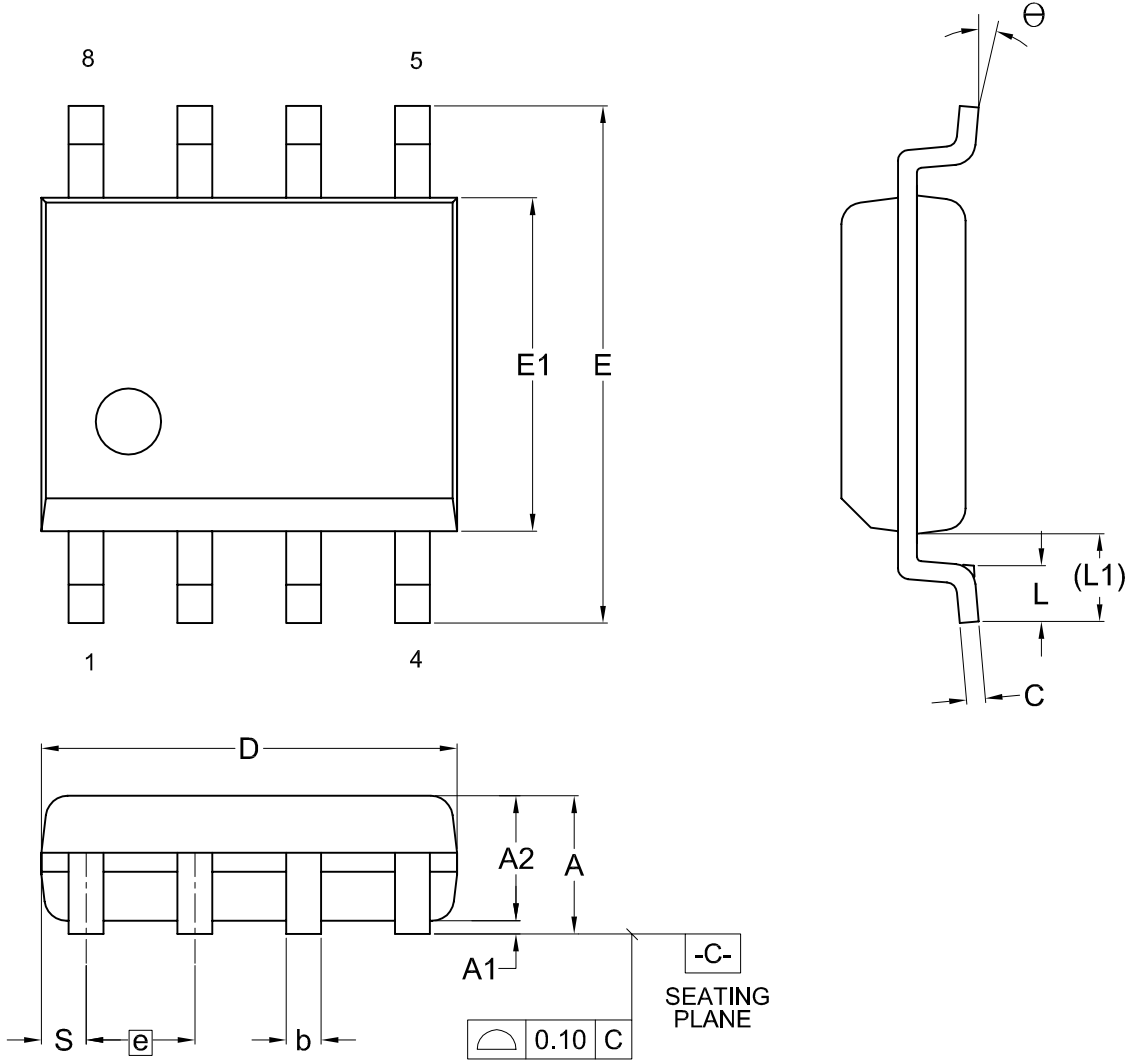

Dimensions (inch dimensions are derived from the original mm dimensions)

SYMBOL		A	A1	A2	b	C	D	E	E1	e	L	L1	S	θ
UNIT														
mm	Min.	---	0.10	1.35	0.36	0.15	4.77	5.80	3.80		0.46	0.85	0.41	0
	Nom.	---	0.15	1.45	0.41	0.20	4.90	5.99	3.90	1.27	0.66	1.05	0.54	5
	Max.	1.75	0.20	1.55	0.51	0.25	5.03	6.20	4.00		0.86	1.25	0.67	8
Inch	Min.	---	0.004	0.053	0.014	0.006	0.188	0.228	0.150		0.018	0.033	0.016	0
	Nom.	---	0.006	0.057	0.016	0.008	0.193	0.236	0.154	0.050	0.026	0.041	0.021	5
	Max.	0.069	0.008	0.061	0.020	0.010	0.198	0.244	0.158		0.034	0.049	0.026	8

Dwg. No.	Revision	Reference		
		JEDEC	EIAJ	
6110-1401	7	MS-012		

Doc. Title: Package Outline for TSSOP 8L (173MIL)

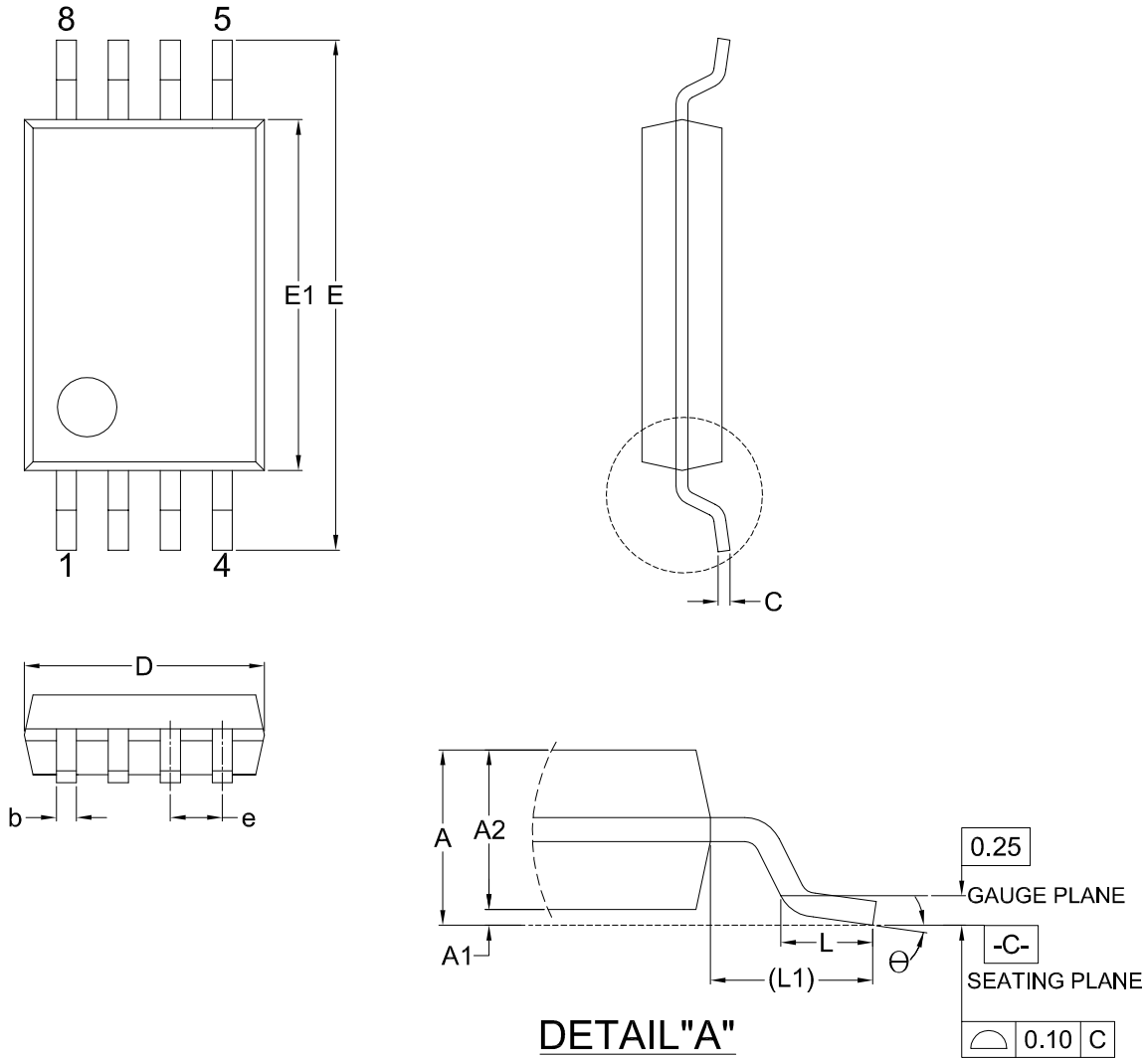

Dimensions (inch dimensions are derived from the original mm dimensions)

SYMBOL		A	A1	A2	b	C	D	E	E1	e	L	L1	θ
mm	Min.	---	0.05	0.80	0.20	0.10	2.90	6.30	4.30	---	0.45	0.85	0
	Nom.	---	0.10	0.90	0.25	0.15	3.00	6.40	4.40	0.65	0.60	1.00	4
	Max.	1.20	0.15	1.00	0.30	0.20	3.10	6.50	4.50	---	0.75	1.15	8
Inch	Min.	---	0.002	0.031	0.008	0.004	0.114	0.248	0.169	---	0.018	0.033	0
	Nom.	---	0.004	0.035	0.010	0.006	0.118	0.252	0.173	0.026	0.024	0.039	4
	Max.	0.047	0.006	0.039	0.012	0.008	0.122	0.256	0.177	---	0.030	0.045	8

Dwg. No.	Revision	Reference		
		JEDEC	EIAJ	
6110-1901.2	1	MO-153		

Doc. Title: Package Outline for USON 8L (2x3x0.6MM, LEAD PITCH 0.5MM)

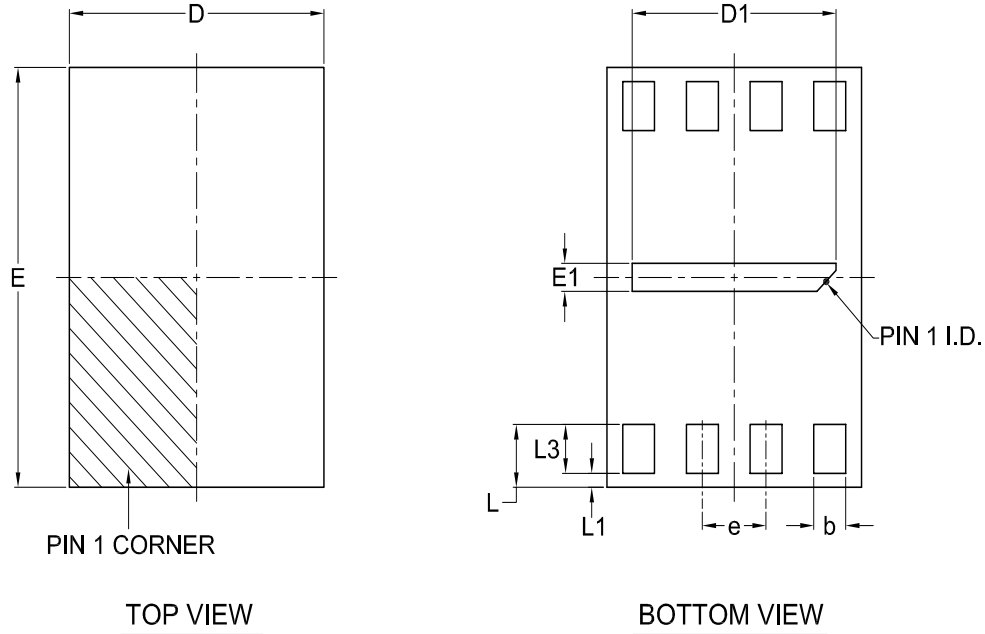

Dimensions (inch dimensions are derived from the original mm dimensions)

*1: This package has exposed metal pad underneath the package , it can't contact to metal trace or pad on board.

*2: The exposed pad size must not violate the min. metal separation requirement, 0.2mm with terminals.

SYMBOL		A	A1	A2	A3	b	D	D1	E	E1	e	L	L1	L3
mm	Min.	0.50	0	--	--	0.20	1.90	1.50	2.90	0.10	--	0.40	--	0.30
	Nom.	0.55	0.035	0.40	0.152	0.25	2.00	1.60	3.00	0.20	0.50	0.45	--	--
	Max.	0.60	0.05	0.425	--	0.30	2.10	1.70	3.10	0.30	--	0.50	0.15	--
Inch	Min.	0.020	0	--	--	0.008	0.075	0.059	0.114	0.004	--	0.016	--	0.012
	Nom.	0.022	0.0014	0.016	0.0060	0.010	0.079	0.063	0.118	0.008	0.020	0.018	--	--
	Max.	0.024	0.002	0.0167	--	0.012	0.083	0.067	0.122	0.012	--	0.020	0.006	--

Dwg. No.	Revision	Reference		
		JEDEC	EIAJ	
6110-3602	3	MO-252		

REVISION HISTORY

Revision No.	Description	Page	Date
0.01	1. Corrected 25L5121 ID code 2. Added VWI into table 7 3. Modified ISB1, ISB2, ICC1, ICC2 & ICC4 4. Modified tDVCH, tCHDX & tCLQV 5. Modified EPN	P12 P22 P4,22,36 P23 P36,37	APR/07/2010
1.0	1. Removed "Advanced Information" 2. Modified Chip Erase time (1Mb) 3. Modified "At Device Power-Up and Power-Down" description 4. Modified ILO test conditions from VIN to VOUT 5. Added 8-USON package information	P4 P23,35 P33 P22 P5,6,36,37,40	NOV/02/2011
1.1	Removed "Advanced Information". Modified Storage Temperature to "-65°C to 150°C"	P5,6,36,37 P20	DEC/29/2011



MACRONIX
INTERNATIONAL Co., LTD.

MX25L5121E
MX25L1021E

Except for customized products which has been expressly identified in the applicable agreement, Macronix's products are designed, developed, and/or manufactured for ordinary business, industrial, personal, and/or household applications only, and not for use in any applications which may, directly or indirectly, cause death, personal injury, or severe property damages. In the event Macronix products are used in contradicted to their target usage above, the buyer shall take any and all actions to ensure said Macronix's product qualified for its actual use in accordance with the applicable laws and regulations; and Macronix as well as it's suppliers and/or distributors shall be released from any and all liability arisen therefrom.

Copyright© Macronix International Co., Ltd. 2010~2011. All rights reserved.

Macronix, MXIC, MXIC Logo, MX Logo, Integrated Solutions Provider, NBit, NBit, Macronix NBit, eLiteFlash, XtraROM, Phines, BE-SONOS, KSMC, Kingtech, MXSMIO, Macronix vEE are trademarks or registered trademarks of Macronix International Co., Ltd. The names and brands of other companies are for identification purposes only and may be claimed as the property of the respective companies.

For the contact and order information, please visit Macronix's Web site at: <http://www.macronix.com>