

**PICDEM™ LCD 2
Demonstration Kit
User's Guide**

Note the following details of the code protection feature on Microchip devices:

- Microchip products meet the specification contained in their particular Microchip Data Sheet.
- Microchip believes that its family of products is one of the most secure families of its kind on the market today, when used in the intended manner and under normal conditions.
- There are dishonest and possibly illegal methods used to breach the code protection feature. All of these methods, to our knowledge, require using the Microchip products in a manner outside the operating specifications contained in Microchip's Data Sheets. Most likely, the person doing so is engaged in theft of intellectual property.
- Microchip is willing to work with the customer who is concerned about the integrity of their code.
- Neither Microchip nor any other semiconductor manufacturer can guarantee the security of their code. Code protection does not mean that we are guaranteeing the product as "unbreakable."

Code protection is constantly evolving. We at Microchip are committed to continuously improving the code protection features of our products. Attempts to break Microchip's code protection feature may be a violation of the Digital Millennium Copyright Act. If such acts allow unauthorized access to your software or other copyrighted work, you may have a right to sue for relief under that Act.

Information contained in this publication regarding device applications and the like is provided only for your convenience and may be superseded by updates. It is your responsibility to ensure that your application meets with your specifications. MICROCHIP MAKES NO REPRESENTATIONS OR WARRANTIES OF ANY KIND WHETHER EXPRESS OR IMPLIED, WRITTEN OR ORAL, STATUTORY OR OTHERWISE, RELATED TO THE INFORMATION, INCLUDING BUT NOT LIMITED TO ITS CONDITION, QUALITY, PERFORMANCE, MERCHANTABILITY OR FITNESS FOR PURPOSE. Microchip disclaims all liability arising from this information and its use. Use of Microchip devices in life support and/or safety applications is entirely at the buyer's risk, and the buyer agrees to defend, indemnify and hold harmless Microchip from any and all damages, claims, suits, or expenses resulting from such use. No licenses are conveyed, implicitly or otherwise, under any Microchip intellectual property rights.

Trademarks

The Microchip name and logo, the Microchip logo, Accuron, dsPIC, KEELOQ, KEELOQ logo, MPLAB, PIC, PICmicro, PICSTART, rPIC, SmartShunt and UNI/O are registered trademarks of Microchip Technology Incorporated in the U.S.A. and other countries.

FilterLab, Linear Active Thermistor, MXDEV, MXLAB, SEEVAL, SmartSensor and The Embedded Control Solutions Company are registered trademarks of Microchip Technology Incorporated in the U.S.A.

Analog-for-the-Digital Age, Application Maestro, CodeGuard, dsPICDEM, dsPICDEM.net, dsPICworks, dsSPEAK, ECAN, ECONOMONITOR, FanSense, In-Circuit Serial Programming, ICSP, ICEPIC, Mindi, MiWi, MPASM, MPLAB Certified logo, MPLIB, MPLINK, mTouch, PICkit, PICDEM, PICDEM.net, PICTail, PIC³² logo, PowerCal, PowerInfo, PowerMate, PowerTool, REAL ICE, rLAB, Select Mode, Total Endurance, WiperLock and ZENA are trademarks of Microchip Technology Incorporated in the U.S.A. and other countries.

SQTP is a service mark of Microchip Technology Incorporated in the U.S.A.

All other trademarks mentioned herein are property of their respective companies.

© 2009, Microchip Technology Incorporated, Printed in the U.S.A., All Rights Reserved.

 Printed on recycled paper.

QUALITY MANAGEMENT SYSTEM
CERTIFIED BY DNV
== ISO/TS 16949:2002 ==

Microchip received ISO/TS-16949:2002 certification for its worldwide headquarters, design and wafer fabrication facilities in Chandler and Tempe, Arizona; Gresham, Oregon and design centers in California and India. The Company's quality system processes and procedures are for its PIC[®] MCUs and dsPIC[®] DSCs, KEELOQ[®] code hopping devices, Serial EEPROMs, microperipherals, nonvolatile memory and analog products. In addition, Microchip's quality system for the design and manufacture of development systems is ISO 9001:2000 certified.



PICDEM™ LCD 2 DEMONSTRATION KIT USER'S GUIDE

Table of Contents

Preface	1
Chapter 1. Introduction	
1.1 Welcome	5
1.2 PICDEM LCD 2 Demonstration Board Hardware Features	6
1.3 Sample Devices	7
1.4 Sample Programs	7
Chapter 2. Getting Started	
2.1 PICDEM LCD 2 as a Stand-Alone Board – Preprogrammed Device	9
2.2 PICDEM LCD 2 Used with an In-Circuit Emulator or In-Circuit Debugger ...	10
Chapter 3. Using the Demo Software	
3.1 Demo Firmware Operation	11
Appendix A. Board Technical Information	
A.1 Processors	19
A.2 LCD Display	20
A.3 LED Display	37
A.4 Charge Pump and VLCAP	37
A.5 RESISTIVE LADDER VERSUS CHARGE PUMP	37
A.6 Oscillator Options	38
A.7 RS-232 Serial Port	38
A.8 Real-Time Clock	38
A.9 Serial EEPROM	38
A.10 Analog Input	38
A.11 Temperature Sensor	39
A.12 Switches	39
A.13 ICD Connector	39
A.14 Power Supply	40
A.15 Board Layout and Schematics	43
A.16 PIM Layout and Schematics	47
Worldwide Sales and Service	56



PICDEM™ LCD 2 DEMONSTRATION KIT USER'S GUIDE

Preface

NOTICE TO CUSTOMERS

All documentation becomes dated, and this manual is no exception. Microchip tools and documentation are constantly evolving to meet customer needs, so some actual dialogs and/or tool descriptions may differ from those in this document. Please refer to our web site (www.microchip.com) to obtain the latest documentation available.

Documents are identified with a "DS" number. This number is located on the bottom of each page, in front of the page number. The numbering convention for the DS number is "DSXXXXA", where "XXXX" is the document number and "A" is the revision level of the document.

For the most up-to-date information on development tools, see the MPLAB® IDE on-line help. Select the Help menu, and then Topics to open a list of available on-line help files.

The VL logo is a registered logo of Varitronix Limited. The illustrations on pages 20, 21, 25, 30, 33 and 36 are copyrighted materials of Varitronix and VL Electronics. Reprinted with permission.

INTRODUCTION

This chapter contains general information that will be useful to know before using the PICDEM™ LCD 2 Demonstration Kit User's Guide. Items discussed in this chapter include:

- About this Guide
- Conventions Used in this Guide
- Recommended Reading
- The Microchip Web Site
- Development Systems Customer Change Notification Service
- Customer Support

ABOUT THIS GUIDE

Document Layout

This document describes how to use the PICDEM LCD 2 as a development tool to emulate and debug firmware on a target board. The manual layout is as follows:

- **Chapter 1. Introduction** – Describes the hardware of the PICDEM LCD 2 Demonstration Board.
- **Chapter 2. Getting Started** – Describes how to use the PICDEM LCD 2 Demonstration Board.
- **Chapter 3. Using the Demo Software** – Describes how to use the application in Demo mode and also how it can be customized.
- **Appendix A. Board Technical Information** – Shows the schematic and layout diagrams for the PICDEM LCD 2 Demonstration Board.

CONVENTIONS USED IN THIS GUIDE

This manual uses the following documentation conventions:

DOCUMENTATION CONVENTIONS

Description	Represents	Examples
Arial font:		
Italic characters	Referenced books	<i>PICDEM LCD 2 User's Guide</i>
	Emphasized text	...is the <i>only</i> compiler...
Initial caps	A window	the Output window
	A dialog	the Settings dialog
	A menu selection	select Enable Programmer
Quotes	A field name in a window or dialog	"Save project before build"
Underlined, italic text with right angle bracket	A menu path	<u><i>File>Save</i></u>
Bold characters	A dialog button	Click OK
	A tab	Click the Power tab
Text in angle brackets < >	A key on the keyboard	Press <Enter>, <F1>
Courier font:		
Plain Courier New	Sample source code	#define START
	Filenames	autoexec.bat
	File paths	c:\mcc18\h
	Keywords	_asm, _endasm, static
	Command-line options	-Opa+, -Opa-
	Bit values	0, 1
	A binary number	'b00100, 'b10
Italic Courier New	A variable argument	<i>file.o</i> , where <i>file</i> can be any valid filename
0xnxxx	A hexadecimal number where n is a hexadecimal digit	0xFFFF, 0x007A
Square brackets []	Optional arguments	mcc18 [options] <i>file</i> [options]
Curly brackets and pipe character: { }	Choice of mutually exclusive arguments; an OR selection	errorlevel {0 1}
Ellipses...	Replaces repeated text	var_name [, var_name...]
	Represents code supplied by user	void main (void) {... }

PICDEM™ LCD 2 Demonstration Kit User's Guide

RECOMMENDED READING

This user's guide describes how to use the PICDEM LCD 2 Demonstration Kit. Other useful documents are listed below. The following Microchip documents are available and recommended as supplemental reference resources.

Readme Files

For the latest information on using other tools, read the tool-specific Readme files in the Readmes subdirectory of the MPLAB® IDE installation directory. The Readme files contain update information and known issues that may not be included in this user's guide.

The following documents are comprehensive references for Microchip's enhanced microcontrollers with LCD driver:

- "PIC18F85J90 Family Data Sheet" (DS39770)*
- "PIC18F87J90 Family Data Sheet" (DS39933)*
- "PIC18F6390/6490/8390/8490 Data Sheet" (DS39629)*
- "PIC16C9XX Data Sheet" (DS30444)*
- "PIC16C925/926 Data Sheet" (DS39544)*
- "PIC16F917/916/914/913 Data Sheet" (DS41250)*

THE MICROCHIP WEB SITE

Microchip provides online support via our web site at www.microchip.com. This web site is used as a means to make files and information easily available to customers. Accessible by using your favorite Internet browser, the web site contains the following information:

- **Product Support** – Data sheets and errata, application notes and sample programs, design resources, user's guides and hardware support documents, latest software releases and archived software
- **General Technical Support** – Frequently Asked Questions (FAQs), technical support requests, online discussion groups, Microchip consultant program member listing
- **Business of Microchip** – Product selector and ordering guides, latest Microchip press releases, listing of seminars and events, listings of Microchip sales offices, distributors and factory representatives

DEVELOPMENT SYSTEMS CUSTOMER CHANGE NOTIFICATION SERVICE

Microchip's customer notification service helps keep customers current on Microchip products. Subscribers will receive e-mail notification whenever there are changes, updates, revisions or errata related to a specified product family or development tool of interest.

To register, access the Microchip web site at www.microchip.com, click on Customer Change Notification and follow the registration instructions.

The Development Systems product group categories are:

- **Compilers** – The latest information on Microchip C compilers and other language tools. These include the MPLAB C17, MPLAB C18 and MPLAB C30 C compilers; MPASM™ and MPLAB ASM30 assemblers; MPLINK™ and MPLAB LINK30 object linkers; and MPLIB™ and MPLAB LIB30 object librarians.
- **Emulators** – The latest information on Microchip in-circuit emulators. This includes the MPLAB ICE 2000 and MPLAB ICE 4000.
- **In-Circuit Debuggers** – The latest information on the Microchip in-circuit debugger, MPLAB ICD 2.
- **MPLAB IDE** – The latest information on Microchip MPLAB IDE, the Windows® operating system Integrated Development Environment for development systems tools. This list is focused on the MPLAB IDE, MPLAB SIM and MPLAB SIM30 simulators, MPLAB IDE Project Manager and general editing and debugging features.
- **Programmers** – The latest information on Microchip programmers. These include the MPLAB PM3 and PRO MATE® II device programmers and the PICSTART® Plus development programmer.

CUSTOMER SUPPORT

Users of Microchip products can receive assistance through several channels:

- Distributor or Representative
- Local Sales Office
- Field Application Engineer (FAE)
- Technical Support
- Development Systems Information Line

Customers should contact their distributor, representative or field application engineer (FAE) for support. Local sales offices are also available to help customers. A listing of sales offices and locations is included in the back of this document.

Technical support is available through the web site at:

<http://support.microchip.com>

In addition, there is a Development Systems Information Line which lists the latest versions of Microchip's development systems software products. This line also provides information on how customers can receive currently available upgrade kits.

The Development Systems Information Line numbers are:

1-800-755-2345 – United States and most of Canada

1-480-792-7302 – Other International Locations



PICDEM™ LCD 2 DEMONSTRATION KIT USER'S GUIDE

Chapter 1. Introduction

1.1 WELCOME

Thank you for purchasing the PICDEM LCD 2 Demonstration Kit from Microchip Technology Incorporated. The PICDEM LCD 2 demonstrates the capabilities of the PIC18FXXJ90, PIC18FXX90 and PIC16X9XX families of devices.

The PICDEM LCD 2 can be used stand-alone with a preprogrammed part, with an in-circuit emulator (e.g., MPLAB® ICE) or with an in-circuit debugger (e.g., MPLAB ICD 2). Sample programs are provided to demonstrate the unique features of the supported devices.

The PICDEM LCD 2 Demonstration Kit comes with the following:

1. PICDEM LCD 2 Demonstration Board (Figure 1-1)
2. Sample Plug-in Module (PIM)
3. CD-ROM which contains:
 - Sample Programs
 - *"PICDEM™ LCD 2 Demonstration Kit User's Guide"*

If you are missing any part of the kit, please contact your nearest Microchip sales office listed in the back of this publication for help.

1.2 PICDEM LCD 2 DEMONSTRATION BOARD HARDWARE FEATURES

The PICDEM LCD 2 Demonstration Board has the following hardware features; each feature's number corresponding to the number in Figure 1-1:

1. The demonstration board provides a daughter board option for the PIC18F85J90, PIC18F87J90, PIC18F8490, PIC16F914/917 and PIC16F946 families of devices and MPLAB ICE. The board is also supplied with a PIM populated with a PIC18F85J90 device.

Note: Optional PIMs populated with PIC18FXX90 and PIC16F9XX devices are available for purchase from Microchip Direct (www.microchipdirect.com).

The MPLAB ICE can be plugged onto the board without any transition socket for PIC18FXX90 devices. For other devices, a transition socket may be needed.

2. On-board adjustable voltage regulator for direct input from 9V, 100 mA AC/DC wall adapter or 3V button cell battery.
3. Jumper J15 to select different power options.
4. Green power-on indicator LED for direct input from 9V.
5. Varitronix custom segmented LCD display.
6. Jumpers, COM0, COM1, COM2 and COM3, to disconnect COM pins from on-board LCD and allow the usage of any customized LCD glass.
7. RS-232 connection and associated hardware for direct connection to RS-232 interface.
8. Jumpers, JP13 and JP14, to disconnect TX and RX.
9. In-Circuit Debugger (ICD) connector.
10. R44, 10 k Ω , potentiometer for devices with analog inputs.
11. Five push button switches (S1 through S5) for external stimulus and Reset.
12. Jumpers, JP19, JP18, JP1 and JP2, to disconnect switches from RB6, RB7, RA6 and RA7 input pins.
13. Jumper, J11, to select either 10 k Ω (POT R44) or the S1-S4 switches to AN0 (RA0).
14. Two green LEDs connected to RC3 and RC4 (device dependent).
15. Jumpers in J14 to disconnect LEDs from RC3 and RC4.
16. A slide switch (S6) to select either the resistor ladder or the charge pump option for generating the bias values for the LCD pins.
17. Jumper, JP21, to physically tie the resistor ladder to ground.
18. Unpopulated holes provided for crystal connection.
19. Jumpers, JP11 and JP12, to disconnect crystal from OSC1 and OSC2.
20. 32.768 kHz crystal with Timer1 for Real-Time Clock (RTC) operation.
21. A Microwire EEPROM 93AA46C provided on a socket.
22. Jumpers, JP15 and JP16, to disconnect EEPROM from CK and DT. Jumper, J6, to connect CS to GND or to RC4 (device dependent). Jumper, J13, to select either 128 x 8 or 64 x 16 memory organization.
23. Thermistor for sensing temperature.
24. Jumper, JP5, to connect thermistor to AN1 (RA1) (device dependent).
25. Jumper, JP17, to select either Vcc or I/O to power the peripherals.
26. Unpopulated option for TC77 temperature sensor.
27. Prototype area for user hardware.
28. PICtail™ daughter board connection. (The pin names on the board are valid only for the PIC18F8490 device. For other devices, the PICtail daughter board pin connections may be different or not connected.)

PICDEM™ LCD 2 Demonstration Kit User's Guide

FIGURE 1-1: PICDEM™ LCD 2 HARDWARE

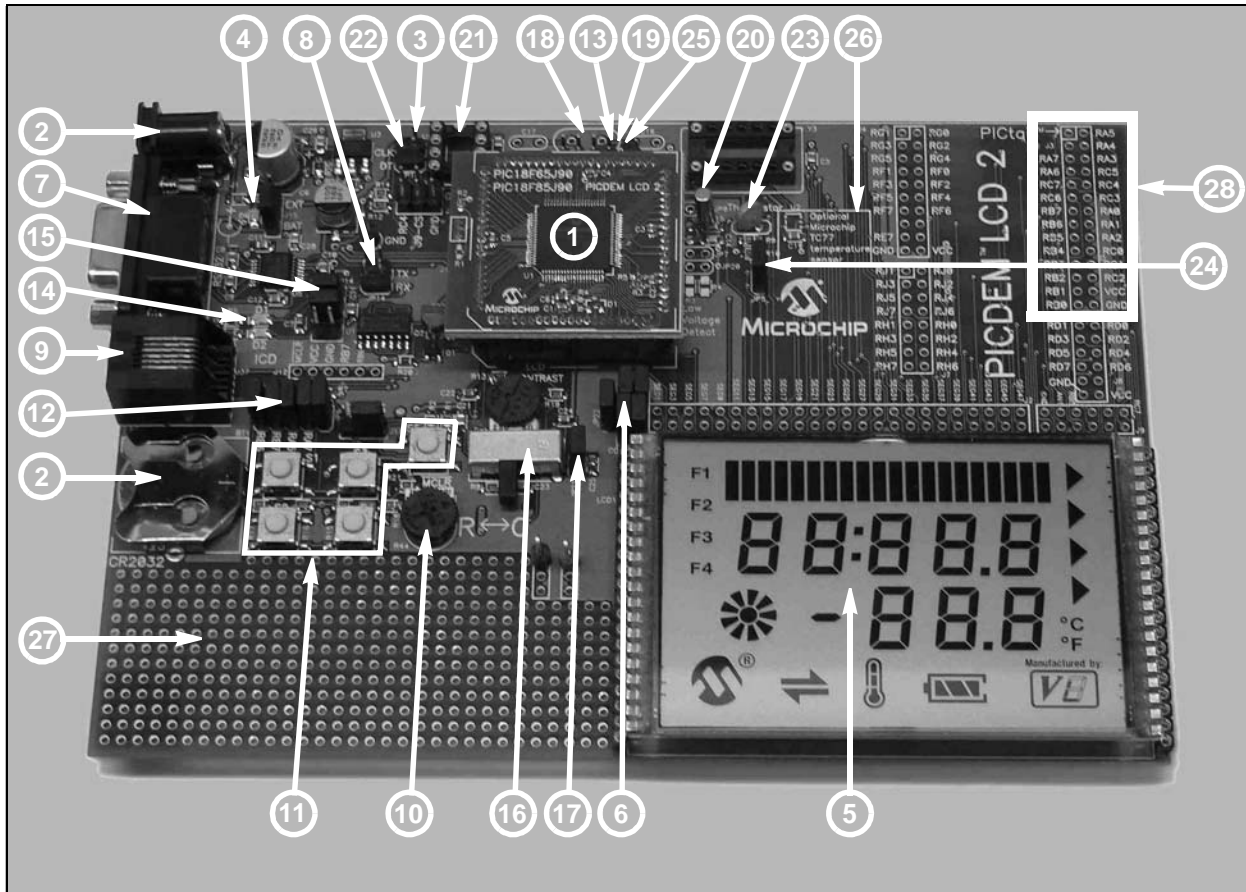

1.3 SAMPLE DEVICES

A PIM, populated with the PIC18F85J90, is included.

1.4 SAMPLE PROGRAMS

The PICDEM LCD 2 Demonstration Kit includes a CD-ROM with sample demonstration programs. Depending on the device, these programs may be used with some of the included sample devices with an In-Circuit Emulator (ICE) or with an In-Circuit Debugger (ICD). For each type of device (PIC16F946, PIC16F917, PIC18F8490, PIC18F85J90 and PIC18F87J90), demo source code, several C and/or .asm files and compiled code (one HEX file) are provided.

NOTES:

Chapter 2. Getting Started

The PICDEM LCD 2 may be used as a stand-alone board with a preprogrammed device, with an In-Circuit Emulator (ICE) or with an In-Circuit Debugger (ICD). For a list of PIC® microcontroller compatible ICEs or ICDs, please refer to the *“Microchip Development Systems Ordering Guide”* (DS30177).

2.1 PICDEM LCD 2 AS A STAND-ALONE BOARD – PREPROGRAMMED DEVICE

The PICDEM LCD 2 may be demonstrated immediately by following the steps listed below:

- Apply power to the PICDEM LCD 2. For information on acceptable power sources, see **Appendix A. “Board Technical Information”**.

Note: In the event that the preprogrammed PICDEM LCD 2 Demonstration Board with the PIC18F85J90 PIM does not operate, check the following conditions:

- The jumper, J15, is configured as per the power supply used. The slide switch, S6, is switched to C.
- JP1, JP2, JP6, JP18 and JP19 are connected.
- The middle two jumpers of J14 are connected.
- JP9 and JP10 are connected.
- J11 connecting POT to AN0 and JP17 connecting Vcc to I/O.

The status of all other jumpers will not affect the preprogrammed demonstration.

Refer to Figure A-1 in **Appendix A. “Board Technical Information”**.

To reprogram the sample device, the following will be necessary:

1. User source code may be programmed to the device or the sample program may be restored from the file on the included CD-ROM.
2. An assembler, such as the MPASM™ Assembler (available with MPLAB IDE), or a compiler, such as MPLAB C18 C Compiler (PIC18XXXX/18XXJXX devices only) must be used.

Source code must be assembled or compiled into a HEX file before it can be programmed into the device. Microchip Technology's MPASM Assembler or MPLAB C18 C Compiler may be used. Both are compatible with MPLAB IDE; however, other assemblers/compilers may be used.

3. Once the sample program is in the HEX file format, it can be programmed to a Flash device using an MPLAB ICD 2 or PM3 with an ICSP™ module. Microchip Technology's MPLAB ICD 2 is compatible with MPLAB IDE.

If the code protection bit(s) have not been programmed, the on-chip program memory can be read out for verification purposes.

2.2 PICDEM LCD 2 USED WITH AN IN-CIRCUIT EMULATOR OR IN-CIRCUIT DEBUGGER

To use the PICDEM LCD 2 with an In-Circuit Emulator (ICE) or In-Circuit Debugger (ICD), refer to the tool's user's guide for instructions on how to power-up and configure the ICE/ICD, as well as how to connect to target boards.

Configure the PICDEM LCD 2 for the desired oscillator as described in Table 2-1. Refer to the ICE/ICD user's guide for any oscillator configuration requirements.

TABLE 2-1: OSCILLATOR SELECTION

Oscillator Selection on PICDEM™ LCD 2	Modification on PICDEM™ LCD 2
Crystal	JP9 and JP10 not connected. No canned oscillator on board, crystal in Y2, JP11 and JP12 connected, caps in C16 and C17.
Canned Oscillator	Put canned oscillator on socket Y3. Y2 empty, JP9, JP11 and JP12 not connected.
Device Internal Oscillator	JP11 and JP12 not connected. No canned oscillator on board.
Ceramic Resonator – no internal caps	JP9 and JP10 not connected. No canned oscillator on board, resonator in Y2, JP11 and JP12 connected, caps in C16 and C17.
Ceramic Resonator – with internal caps	JP9 and JP10 not connected. No canned oscillator on board, resonator in Y2, JP11 and JP12 connected, C16 and C17 empty.

Note: The MPLAB ICE can be plugged onto the board without any transition socket for PIC18FXX90 devices. For other devices, a transition socket may be needed.

Chapter 3. Using the Demo Software

The demo programs are preprogrammed into the sample devices. Also, this program is included on the CD-ROM program disk for user reference. This demo program uses the functions or macros provided by the firmware LCD driver module to display the required characters, strings or icons on the LCD.

3.1 DEMO FIRMWARE OPERATION

The demo firmware is made up of four components, which are individually displayed on the LCD. The PIC microcontroller's internal RC oscillator is used as the system clock source.

1. **Voltmeter (F1)**

This mode uses the A/D module to measure the voltage of the R44 pot through analog channel AN0, and displays a voltage between 0.00V and 3.30V on the LCD using the LCD module. Voltage is continually updated until the mode is exited by pressing either the S1 or S2 switch.

2. **Thermometer (F2)**

This mode uses the A/D module to measure the voltage of the thermistor R11 through analog channel AN1, and converts to temperature both in Celsius and Fahrenheit and displays the temperature on the LCD using the LCD module. Temperature is continually updated until the mode is exited by pressing either the S1 or S2 switch.

3. **Clock (F3)⁽¹⁾**

This mode uses the Timer1 module and a 32 kHz clock crystal. Once this mode is entered from the main menu, the Real-Time Clock will start counting from 00:00:00. The S3 switch is used to increment minutes and the S4 switch is used to increment hours. To perform the increment operations, press and hold the switches. The clock keeps running continuously until the mode is exited by pressing either the S1 or S2 switch.

4. **Charge Pump and Software Contrast (F4)⁽¹⁾**

This mode is available only for the PIC18F85J90 and PIC18F87J90 families of devices and uses the on-board charge pump and LCD voltage regulator. The LCD module is configured in Charge Pump mode and software contrast is achieved by either pressing S3 to increase the contrast or S4 to decrease the contrast until the mode is exited by pressing either the S1 or S2 switch. By exiting this mode, the Voltmeter mode is entered and retains the contrast level.

Note 1: For low-power battery operation in JP17, remove jumper on Vcc and I/O and connect I/O and RB0.

FIGURE 3-2: DEMO PROGRAM FLOWCHART

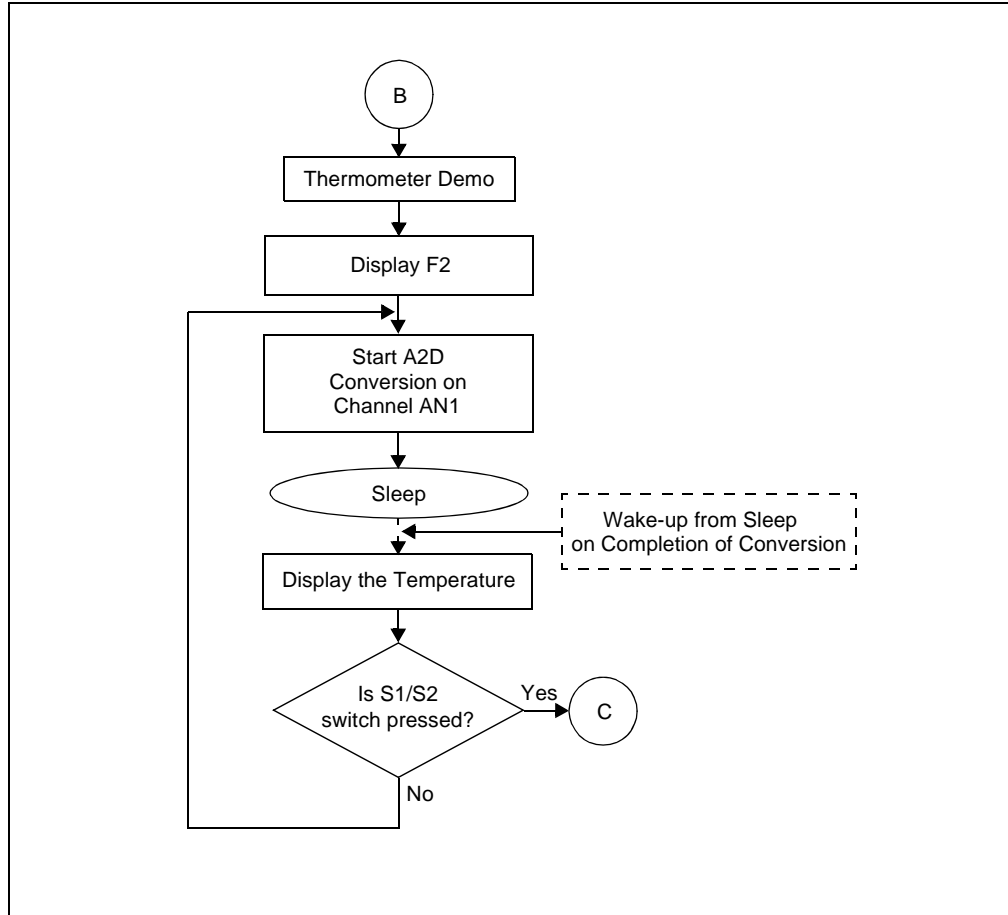
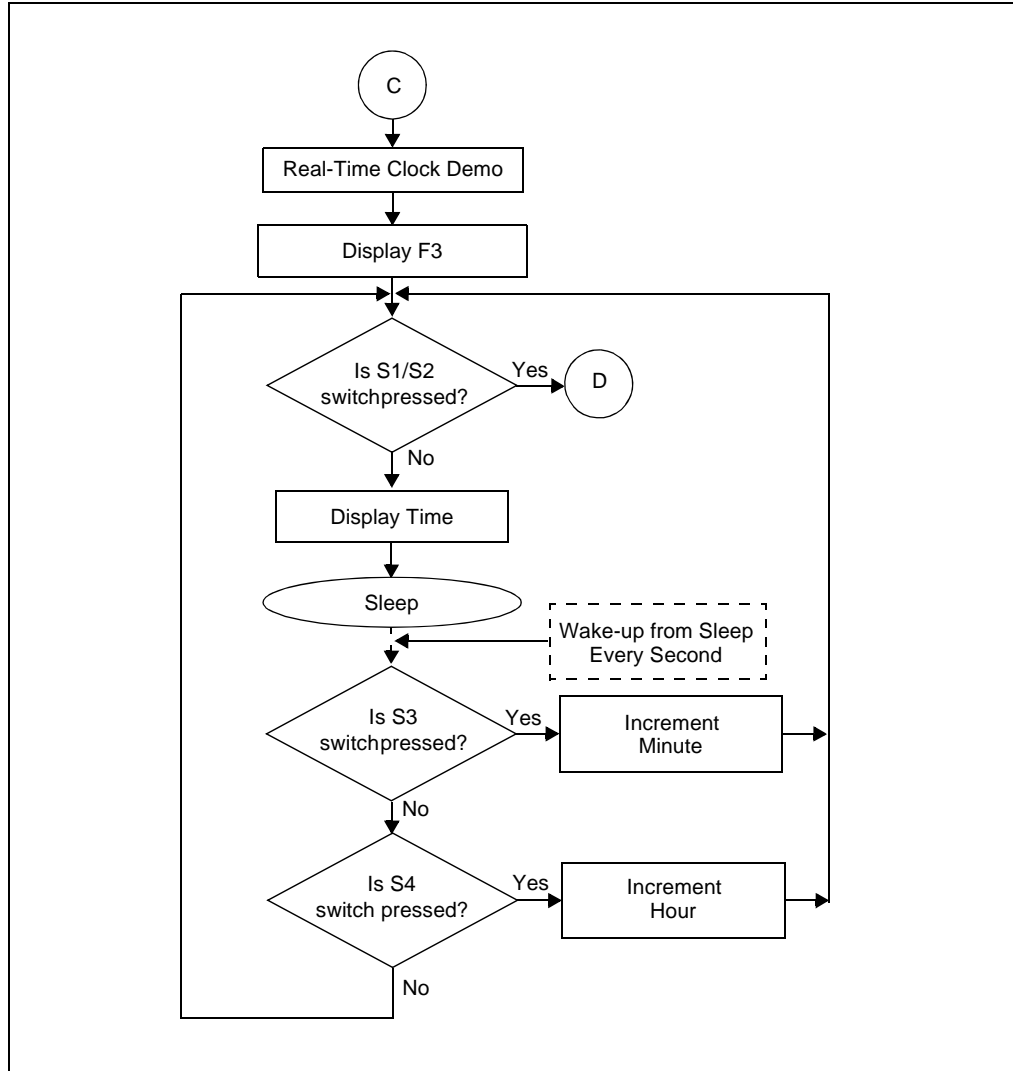

FIGURE 3-3: DEMO PROGRAM FLOWCHART



PICDEM™ LCD 2 Demonstration Kit User's Guide

FIGURE 3-4: DEMO PROGRAM FLOWCHART

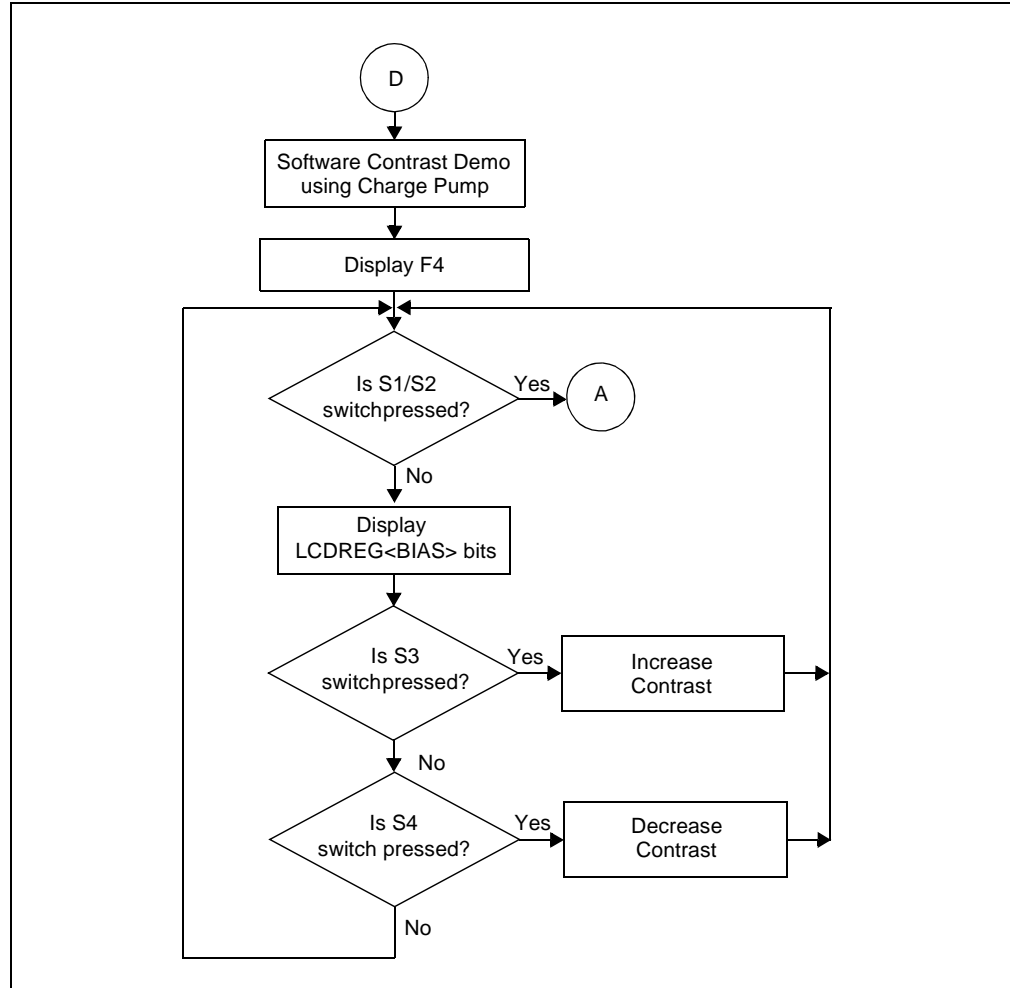
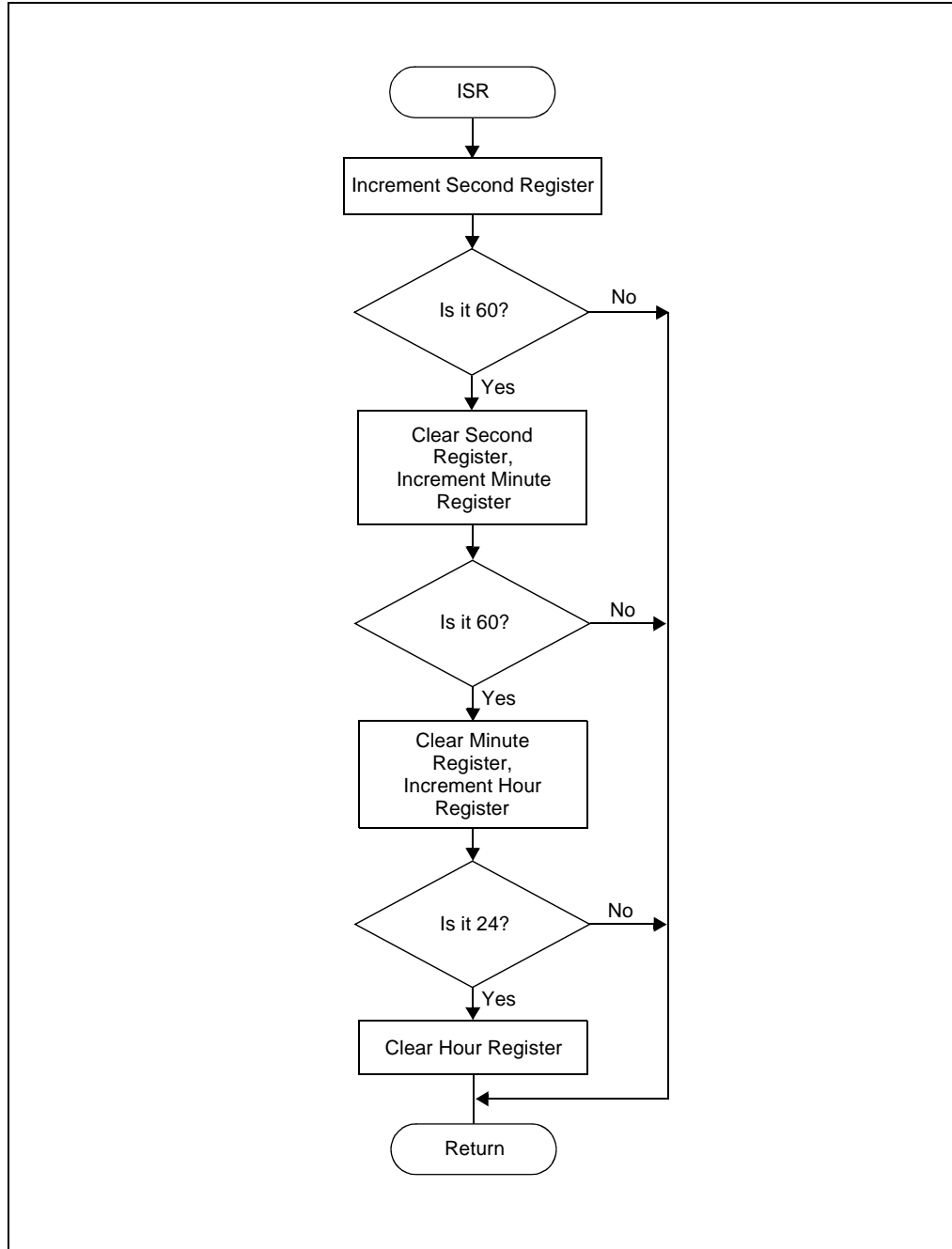

FIGURE 3-5: DEMO PROGRAM FLOWCHART





PICDEM™ LCD 2 DEMONSTRATION KIT USER'S GUIDE

Appendix A. Board Technical Information

The PICDEM LCD 2 hardware is not complicated and is intended to illustrate the ease of use of various PIC® microcontrollers. The PICDEM LCD 2 features the following hardware elements.

Note: Many of the following hardware sections will require specific demo board jumper configurations. If a jumper is not listed in a particular section, then that jumper has no effect on the circuitry within the hardware section you are working. Figure A-1 shows a diagram of the PICDEM LCD 2 silkscreen with all necessary jumpers highlighted in gray. Also, refer to the schematic for circuit connections.

FIGURE A-1: PICDEM™ LCD 2 DEFAULT JUMPER LOCATION

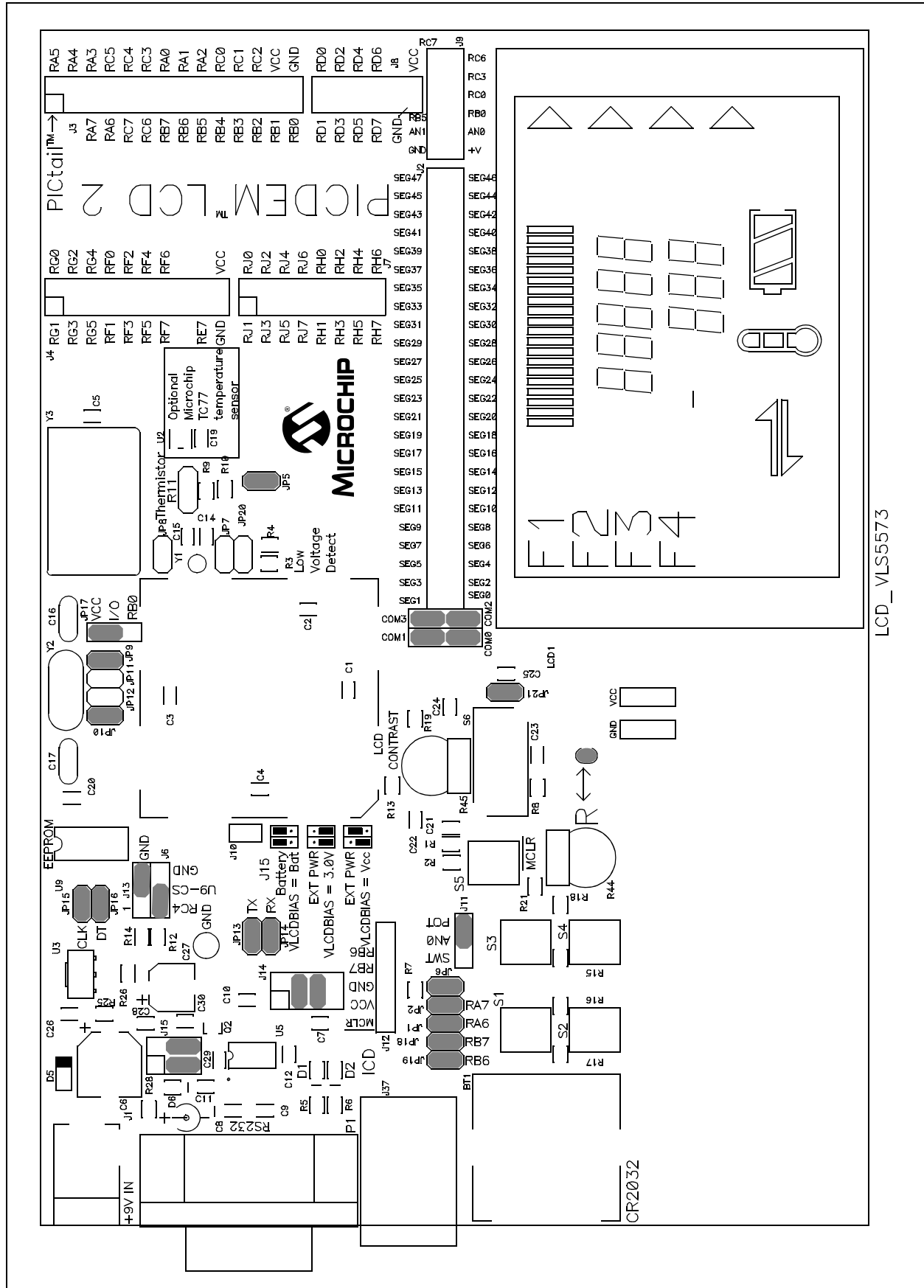

LCD_VLS5573

PICDEM™ LCD 2 Demonstration Kit User's Guide

A.1 PROCESSORS

While there is no actual processor populated on the board, a processor is provided with the plug-in module (PIM) that is shipped with the demonstration board. The default processor on the PIM is the PIC18F85J90.

The board also supports the PIC18F87J90, PIC18F8490, PIC16F946 and PIC16F917 processors, which have been designed for use with the PICDEM LCD 2. These three processors are in the PICDEM LCD 2 PIM Pack which is available for separate purchase.

The part numbers for a replacement PIC18F85J90 and the PIM pack are given in Table A-1.

TABLE A-1: PART NUMBERS(†)

Item	Part number
PICDEM LCD 2 PIM Pack <ul style="list-style-type: none">• PIC18F8490 PIM• PIC16F946 PIM• PIC16F917 PIM	MA180019
PIC18F85J90 PIM	MA180022

† For the availability and pricing of parts, go to www.microchipdirect.com.

A.2 LCD DISPLAY

A custom made segmented LCD glass, manufactured by the Varitronix Corporation, is provided as shown in Figure A-2. This LCD has 4 commons and 32 segments. Table A-2 provides a few of the specifics for the display. Refer to the Varitronix specification sheet (VL_5573_V00) for additional details.

FIGURE A-2: PICDEM™ LCD 2 DISPLAY

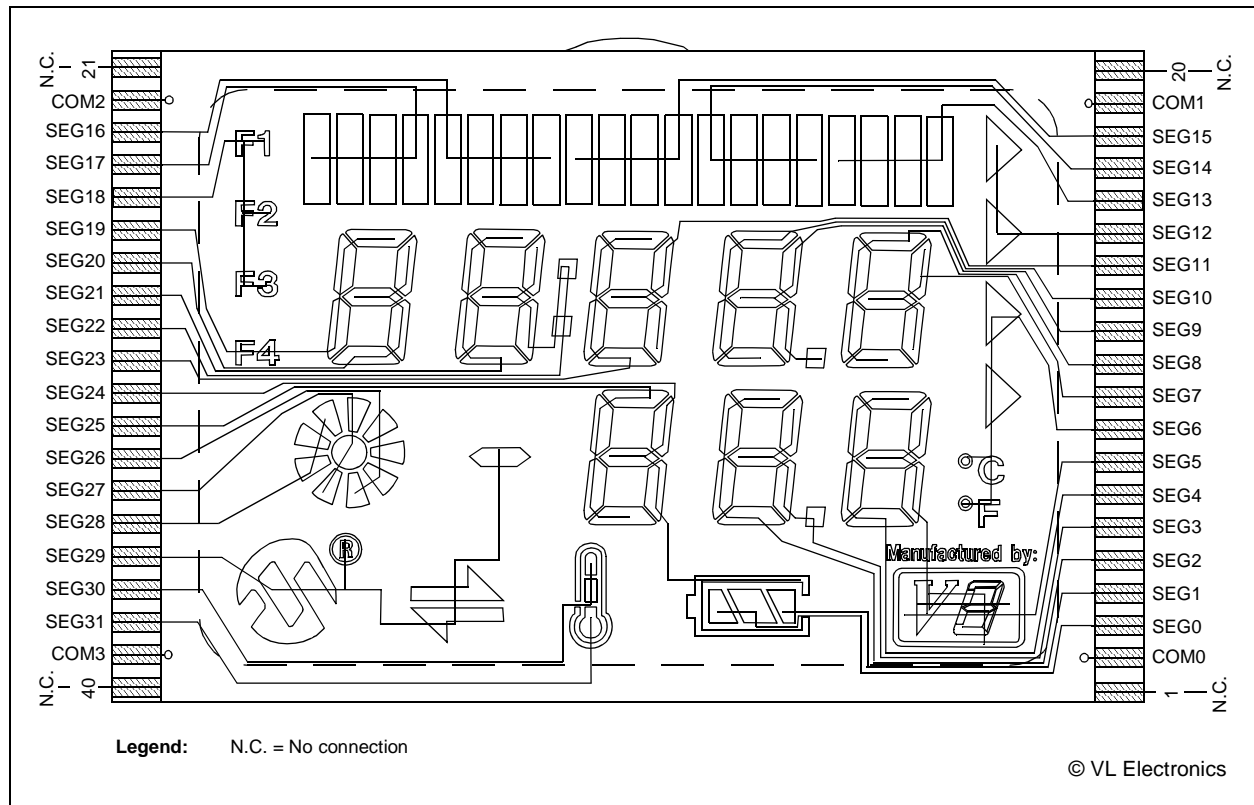

TABLE A-2: LCD GLASS SPECIFICATIONS

Type	Specification
P.I.D.	VL_5573_V00
Mode/Color/Type	Positive / -- / TN
Viewing Direction	6:00 O'Clock
Driving Scheme	1/4 Duty, 1/3 Bias
Drive Voltage (VLCD)	~3.0 Volt (p-p), +20°C
Operating Temperature	0°C - +50°C
Storage Temperature	-10°C - +60°C
Polarizer – Front	STD.Transmissive
Polarizer – Back	STD.Reflective

Since the glass used on the PICDEM LCD 2 operates at 3V, there is a voltage protection circuit on the LCDBIAS3 pin, which is enabled in the default configuration. When enabled, even if the VDD is greater than 3V, it regulates the LCDBIAS3 voltage such that it always maintains the value to 3V. This is not necessary for operation of the LCD module, but it is a protection circuit to prevent accidentally applying voltages higher than 3V to the LCD glass present on the board.

PICDEM™ LCD 2 Demonstration Kit User's Guide

FIGURE A-3: DISPLAY DEFINITIONS

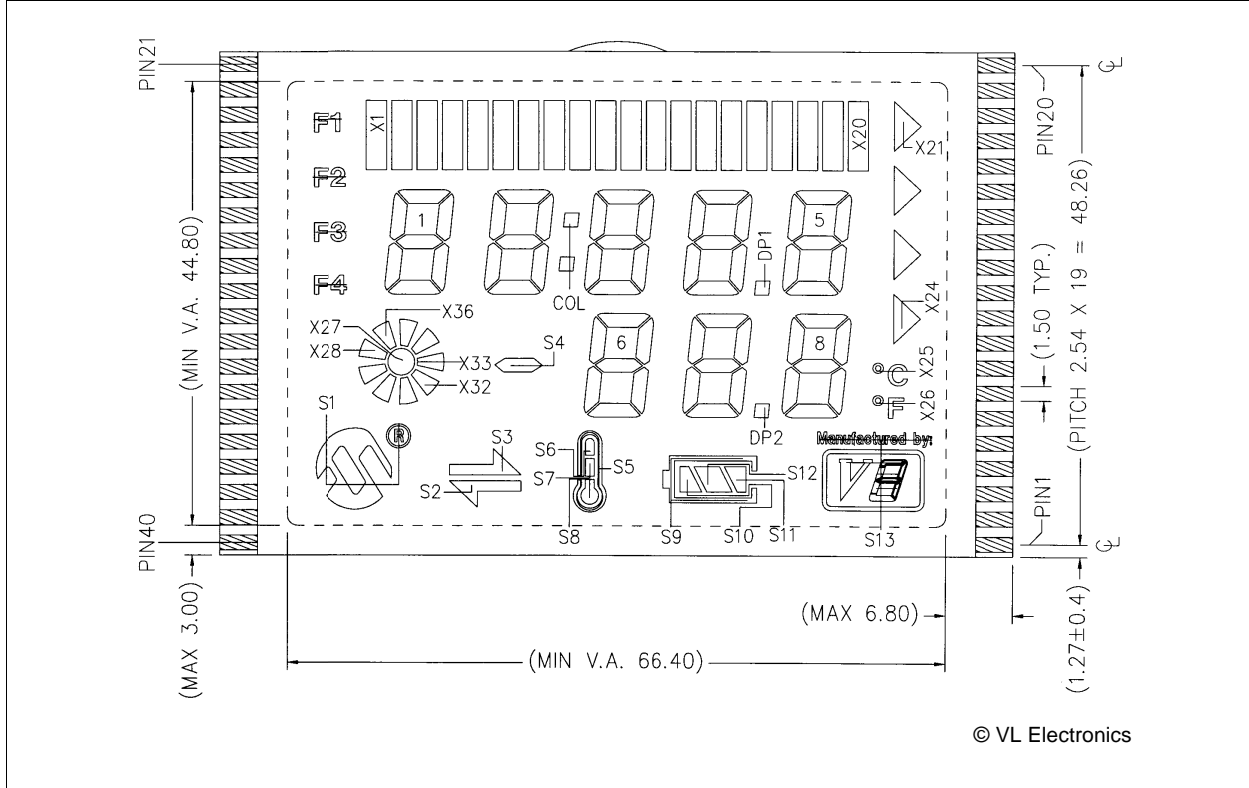

FIGURE A-4: DIGIT DESCRIPTION

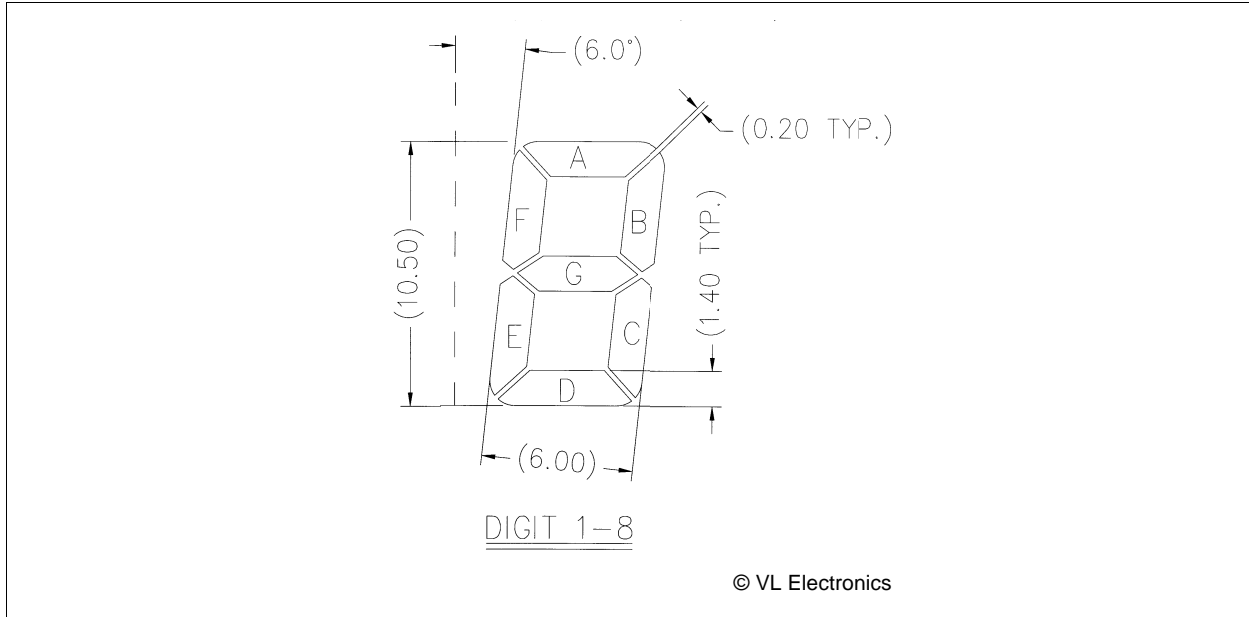

TABLE A-3: LCD SEGx AND COMx

Pin	ICE Pin	COM0	COM1	COM2	COM3
1		N.C.	N.C.	N.C.	N.C.
2		COM0	—	—	—
3	SEG0	S12	—	—	S10
4	SEG1	S11	—	—	—
5	SEG2	7D	7F	7A	7E
6	SEG3	DP2	7G	7B	7C
7	SEG4	8D	8F	8A	8E
8	SEG5	S13	8G	8B	8C
9	SEG6	X23	X25	X26	X24
10	SEG7	5B	5C	—	5G
11	SEG8	5A	5E	5D	5F
12	SEG9	4B	4C	DP1	4G
13	SEG10	4A	4E	4D	4F
14	SEG11	3B	3C	—	3G
15	SEG12	—	X22	X21	—
16	SEG13	X17	X19	X20	X18
17	SEG14	X16	X14	X13	X15
18	SEG15	X9	X11	X12	X10
19		—	COM1	—	—
20		N.C.	N.C.	N.C.	N.C.
21		N.C.	N.C.	N.C.	N.C.
22		—	—	COM2	—
23	SEG16	X8	X6	X5	X7
24	SEG17	X1	X3	X4	X2
25	SEG18	—	F2	F1	F3
26	SEG19	1A	1E	F4	1F
27	SEG20	1B	1C	1D	1G
28	SEG21	2A	2E	2D	2F
29	SEG22	2B	2C	COL	2G
30	SEG23	3A	3E	3D	3F
31	SEG24	S9	6G	6B	6C
32	SEG25	6D	6F	6A	6E
33	SEG26	X31	X33	X34	X32
34	SEG27	—	X27	X35	X30
35	SEG28	—	X28	X36	X29
36	SEG29	S1	S3	S4	S2
37	SEG30	S6	—	—	S7
38	SEG31	S5	—	—	S8
39		—	—	—	COM3
40		N.C.	N.C.	N.C.	N.C.

Legend: N.C. = No connection

PICDEM™ LCD 2 Demonstration Kit User's Guide

A.2.1 Device-Specific LCD Segment Configuration

The following figures and tables detail which segments are available for specific PIC® devices.

TABLE A-4: PIC18F85J90 PIM AND ICE PIN/PORT COMPARISON

PIC18F85J90 PIM Pin No.	PIC18F85J90 Port	PIC18F85J90 Pin	ICE Pin	ICE Port	ICE Pin No.	PIC18F85J90 PIM Pin No.	PIC18F85J90 Port	PIC18F85J90 Pin	ICE Pin	ICE Port	ICE Pin No.
1	RH2	SEG45	SEG30	RG0	16	41	RJ6	SEG37	SEG37	RJ6	54
2	RH3	SEG44	SEG29	RG1	17	42	RJ7	SEG36	SEG36	RJ7	55
3	RE1	BIAS2	BIAS2	RE1	14	43	RC2	SEG13	SEG13	RC2	56
4	RE0	BIAS1	BIAS1	RE0	15	44	RC3	SEG17	SEG17	RA3	39
5	RG0	BIAS0	BIAS0	RB5	67	45	RC4	SEG16	SEG16	RA2	40
6	RG1	NC	NC			46	RC5	SEG12	SEG12	RC5	59
7	RG2	VLCAP1	VLCAP1	RC3	57	47	RB7	RB7	RB7	RB7	60
8	RG3	VLCAP2	VLCAP2	RC4	58	48	VDD	ICEVDD	ICEVDD	VDD	61
9	RG5	$\overline{\text{MCLR}}$	ICEMCLR	RG5	20	49	RA7	OSC1	OSC1	RA7	62
10	RG4	SEG26	SEG26	RG4	21	50	RA6	OSC2	OSC2	RA6	63
11	VSS	VSS	VSS	VSS	23	51	VSS	VSS	VSS	VSS	65
12	VDDCORE	VDDCORE	VDD	VDD	24	52	RB6	RB6	RB6	RB6	66
13	RF7	SEG25	SEG25	RF7	25	53	RB5	SEG29	SEG27	RG3	19
14	RF6	SEG24	SEG24	RF6	26	54	RB4	SEG11	SEG11	RB4	68
15	RF5	SEG23	SEG23	RF5	27	55	RB3	SEG10	SEG10	RB3	69
16	RF4	SEG22	SEG22	RF4	28	56	RB2	SEG9	SEG9	RB2	70
17	RF3	SEG21	SEG21	RF3	29	57	RB1	SEG8	SEG8	RB1	71
18	RF2	SEG20	SEG20	RF2	30	58	RB0	RB0	RB0	RB0	72
19	RH7	SEG43	SEG43	RH7	31	59	RJ3	SEG35	SEG35	RJ3	73
20	RH6	SEG42	SEG42	RH6	32	60	RJ2	SEG34	SEG34	RJ2	74
21	RH5	SEG41	SEG41	RH5	33	61	RJ1	SEG33	SEG33	RJ1	75
22	RH4	SEG40	SEG40	RH4	34	62	RJ0	NC	NC		
23	RF1	SEG19	SEG19	RF1	35	63	RD7	SEG7	SEG7	RD7	77
24	ENVREG	ENVREG				64	RD6	SEG6	SEG6	RD6	78
25	AVDD	AVDD	ICEVDD	AVDD	37	65	RD5	SEG5	SEG5	RD5	79
26	AVSS	AVSS	AVSS	AVSS	38	66	RD4	SEG4	SEG4	RD4	80
27	RA3	NC	NC			67	RD3	SEG3	SEG3	RD3	81
28	RA2	AN2	AN1	RA1	41	68	RD2	SEG2	SEG2	RD2	82
29	RA1	SEG18	SEG18	RF0	36	69	RD1	SEG1	SEG1	RD1	83
30	RA0	AN0	AN0	RA0	42	70	VSS	VSS	VSS	VSS	84
31	VSS	VSS	VSS	VSS	44	71	VDD	VDD	VDD	VDD	2
32	VDD	ICEVDD	ICEVDD	VDD	45	72	RD0	SEG0	SEG0	RD0	3
33	RA5	SEG15	SEG15	RA5	46	73	RE7	SEG31	SEG28	RG2	18
34	RA4	SEG14	SEG14	RA4	47	74	RE6	COM3	COM3	RE6	5
35	RC1	T1OSCI	T1OSCI	RC1	48	75	RE5	COM2	COM2	RE5	6
36	RC0	T1OSCO	T1OSCO	RC0	49	76	RE4	COM1	COM1	RE4	7
37	RC6	TX/CK	TX/CK	RC6	50	77	RE3	COM0	COM0	COM0	8
38	RC7	RX/DT	RX/DT	RC7	51	78	RE2	BIAS3	BIAS3	RE2	9
39	RJ4	SEG39	SEG39	RJ4	52	79	RH0	SEG47	SEG32	RJ0	76
40	RJ5	SEG38	SEG38	RJ5	53	80	RH1	SEG46	SEG31	RE7	4

Legend: Unshaded cells indicate where a perfect match between PIM and ICE pins and ports exists.

Shaded cells indicate where differences between PIM and ICE ports and pins exist.

Bold text indicates the PIM pins that are not connected to any ICE pins or ports.

TABLE A-5: PIC18F85J90 LCD CONNECTIONS COMPARISON

PIC18F85J90	ICE	Pin #			Pin #	ICE	PIC18F85J90
	NC	21	NC		20	NC	
COM2	COM2	22	COM3		19	COM1	COM1
SEG16	SEG16	23	X8,X6,X5,X7		18	SEG15	SEG15
SEG17	SEG17	24	X1,X3,X4,X2		17	SEG14	SEG14
SEG18	SEG18	25	-,F2,F1,F3		16	SEG13	SEG13
SEG19	SEG19	26	1A,1E,F4,1F		15	SEG12	SEG12
SEG20	SEG20	27	1B,1C,1D,1G		14	SEG11	SEG11
SEG21	SEG21	28	2A,2E,2D,2F		13	SEG10	SEG10
SEG22	SEG22	29	2B,2C,COL,2G		12	SEG9	SEG9
SEG23	SEG23	30	3A,3E,3D,3F		11	SEG8	SEG8
SEG24	SEG24	31	S9,6G,6B,6C		10	SEG7	SEG7
SEG25	SEG25	32	6D,6F,6A,6E		9	SEG6	SEG6
SEG26	SEG26	33	X31,X33,X34,X32		8	SEG5	SEG5
SEG29	SEG27	34	-,X27,X35,X30		7	SEG4	SEG4
SEG31	SEG28	35	-,X28,X36,X29		6	SEG3	SEG3
SEG44	SEG29	36	S1,S3,S4,S2		5	SEG2	SEG2
SEG45	SEG30	37	S6,-,-,S7		4	SEG1	SEG1
SEG46	SEG31	38	S5,-,-S8		3	SEG0	SEG0
COM3	COM3	39	COM4		2	COM0	COM0
	NC	40	NC		1	NC	

Legend: Unshaded cells indicate a perfect match between the PIM and the glass.
 Shaded cells indicate the pins that are remapped to the corresponding pin on the PIM.

PICDEM™ LCD 2 Demonstration Kit User's Guide

FIGURE A-5: SEGMENT CONFIGURATION FOR PIC18F85J90 DEVICES

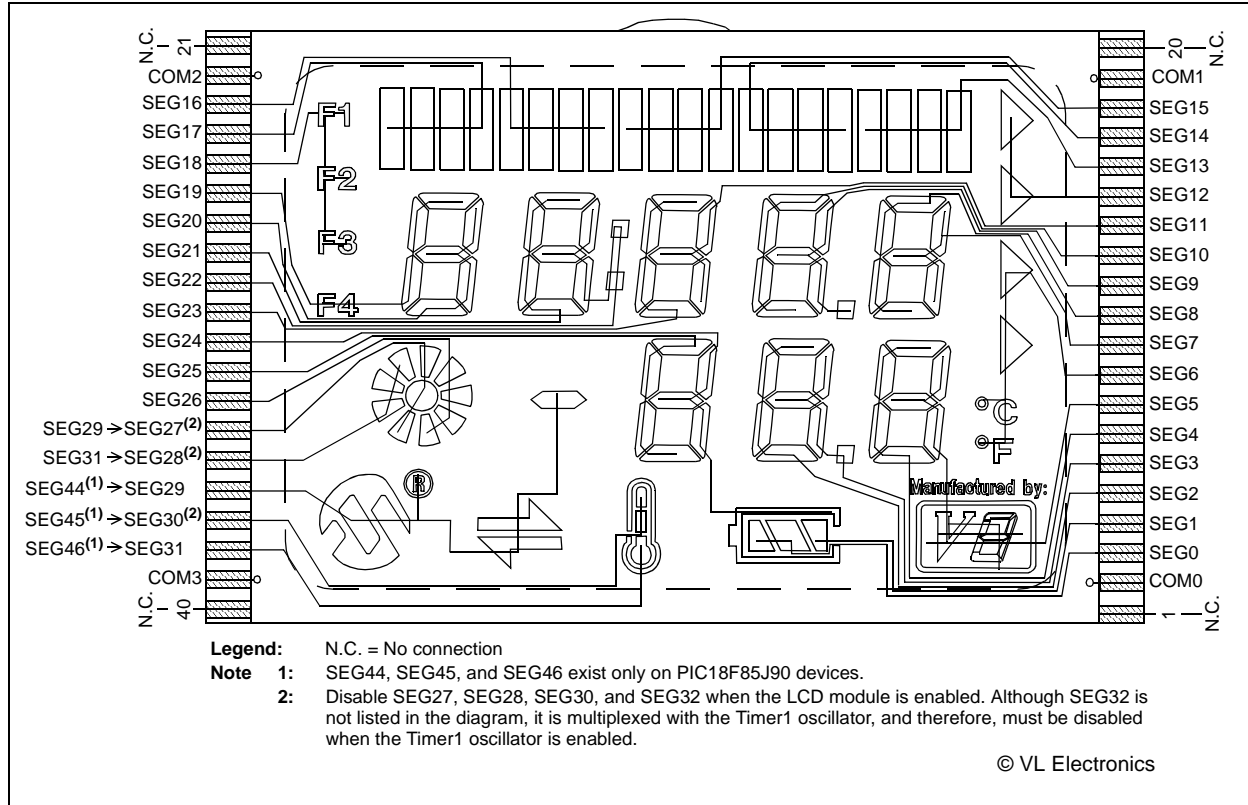

TABLE A-6: PIC18F85J90 PORT AND PIN COMPARISON

PIC18F85J90 Port	PIC18F85J90 PIN	ICE Pin	ICE Port
RA0	AN0	AN0	RA0
RA1	SEG18	SEG18	RF0
RA6	OSC2	OSC2	RA6
RA7	OSC1	OSC1	RA7
RB0	RB0	RB0	RB0
RB5	SEG29	SEG27	RG3
RB6	RB6	RB6	RB6
RB7	RB7	RB7	RB7
RC0	T1OSC1	T1OSC0	RC0
RC1	T1OSC0	T1OSC1	RC1
RC3	SEG17	SEG17	RA3
RC4	SEG16	SEG16	RA2
RC6	TX/CK	TX/CK	RC6
RC7	RX/DT	RX/DT	RC7

Legend: Unshaded cells indicate a perfect match between the PIM and the glass.
 Shaded cells indicate the pins that are remapped to the corresponding pin on the PIM.

TABLE A-7: PIC18F87J90 PIM AND ICE PIN/PORT COMPARISON

PIC18F87J90 PIM Pin No.	PIC18F87J90 Port	PIC18F87J90 Pin	ICE Pin	ICE Port	ICE Pin No.	PIC18F87J90 PIM Pin No.	PIC18F87J90 Port	PIC18F87J90 Pin	ICE Pin	ICE Port	ICE Pin No.
1	RH2	SEG45	SEG30	RG0	16	41	RJ6	SEG37	SEG37	RJ6	54
2	RH3	SEG44	SEG29	RG1	17	42	RJ7	SEG36	SEG36	RJ7	55
3	RE1	BIAS2	BIAS2	RE1	14	43	RC2	SEG13	SEG13	RC2	56
4	RE0	BIAS1	BIAS1	RE0	15	44	RC3	SEG17	SEG17	RA3	39
5	RG0	BIAS0	BIAS0	RB5	67	45	RC4	SEG16	SEG16	RA2	40
6	RG1	NC	NC			46	RC5	SEG12	SEG12	RC5	59
7	RG2	VLCAP1	VLCAP1	RC3	57	47	RB7	RB7	RB7	RB7	60
8	RG3	VLCAP2	VLCAP2	RC4	58	48	VDD	ICEVDD	ICEVDD	VDD	61
9	RG5	MCLR	ICEMCLR	RG5	20	49	RA7	OSC1	OSC1	RA7	62
10	RG4	SEG26	SEG26	RG4	21	50	RA6	OSC2	OSC2	RA6	63
11	VSS	VSS	VSS	VSS	23	51	VSS	VSS	VSS	VSS	65
12	VDDCORE	VDDCORE	VDD	VDD	24	52	RB6	RB6	RB6	RB6	66
13	RF7	SEG25	SEG25	RF7	25	53	RB5	SEG29	SEG27	RG3	19
14	RF6	SEG24	SEG24	RF6	26	54	RB4	SEG11	SEG11	RB4	68
15	RF5	SEG23	SEG23	RF5	27	55	RB3	SEG10	SEG10	RB3	69
16	RF4	SEG22	SEG22	RF4	28	56	RB2	SEG9	SEG9	RB2	70
17	RF3	SEG21	SEG21	RF3	29	57	RB1	SEG8	SEG8	RB1	71
18	RF2	SEG20	SEG20	RF2	30	58	RB0	RB0	RB0	RB0	72
19	RH7	SEG43	SEG43	RH7	31	59	RJ3	SEG35	SEG35	RJ3	73
20	RH6	SEG42	SEG42	RH6	32	60	RJ2	SEG34	SEG34	RJ2	74
21	RH5	SEG41	SEG41	RH5	33	61	RJ1	SEG33	SEG33	RJ1	75
22	RH4	SEG40	SEG18	RF0	34	62	RJ0	NC	NC		
23	RF1	SEG19	SEG19	RF1	35	63	RD7	SEG7	SEG7	RD7	77
24	ENVREG	ENVREG				64	RD6	SEG6	SEG6	RD6	78
25	AVDD	AVDD	ICEVDD	AVDD	37	65	RD5	SEG5	SEG5	RD5	79
26	AVSS	AVSS	AVSS	AVSS	38	66	RD4	SEG4	SEG4	RD4	80
27	RA3	CTMU	NC			67	RD3	SEG3	SEG3	RD3	81
28	RA2	AN2	AN1	RA1	41	68	RD2	SEG2	SEG2	RD2	82
29	RA1	CTMU	NC		36	69	RD1	SEG1	SEG1	RD1	83
30	RA0	AN0	AN0	RA0	42	70	VSS	VSS	VSS	VSS	84
31	VSS	VSS	VSS	VSS	44	71	VDD	VDD	VDD	VDD	2
32	VDD	ICEVDD	ICEVDD	VDD	45	72	RD0	SEG0	SEG0	RD0	3
33	RA5	SEG15	SEG15	RA5	46	73	RE7	SEG31	SEG28	RG2	18
34	RA4	SEG14	SEG14	RA4	47	74	RE6	COM3	COM3	RE6	5
35	RC1	T1OSCI	T1OSCI	RC1	48	75	RE5	COM2	COM2	RE5	6
36	RC0	T1OSCO	T1OSCO	RC0	49	76	RE4	COM1	COM1	RE4	7
37	RC6	TX/CK	TX/CK	RC6	50	77	RE3	COM0	COM0	COM0	8
38	RC7	RX/DT	RX/DT	RC7	51	78	RE2	BIAS3	BIAS3	RE2	9
39	RJ4	SEG39	SEG39	RJ4	52	79	RH0	SEG47	SEG32	RJ0	76
40	RJ5	SEG38	SEG38	RJ5	53	80	RH1	SEG46	SEG31	RE7	4

Legend: Unshaded cells indicate where a perfect match between PIM and ICE pins and ports exists.
 Shaded cells indicate where differences between PIM and ICE ports and pins exist.
Bold text indicates the PIM pins that are not connected to any ICE pins or ports.

PICDEM™ LCD 2 Demonstration Kit User's Guide

TABLE A-8: PIC18F87J90 LCD CONNECTIONS COMPARISON

PIC18F87J90	ICE	Pin #			Pin #	ICE	PIC18F87J90
	NC	21	NC		20	NC	
COM2	COM2	22	COM3		19	COM1	COM1
SEG16	SEG16	23	X8,X6,X5,X7		18	SEG15	SEG15
SEG17	SEG17	24	X1,X3,X4,X2		17	SEG14	SEG14
SEG40	SEG18	25	-,F2,F1,F3		16	SEG13	SEG13
SEG19	SEG19	26	1A,1E,F4,1F		15	SEG12	SEG12
SEG20	SEG20	27	1B,1C,1D,1G		14	SEG11	SEG11
SEG21	SEG21	28	2A,2E,2D,2F		13	SEG10	SEG10
SEG22	SEG22	29	2B,2C,COL,2G		12	SEG9	SEG9
SEG23	SEG23	30	3A,3E,3D,3F		11	SEG8	SEG8
SEG24	SEG24	31	S9,6G,6B,6C		10	SEG7	SEG7
SEG25	SEG25	32	6D,6F,6A,6E		9	SEG6	SEG6
SEG26	SEG26	33	X31,X33,X34,X32		8	SEG5	SEG5
SEG29	SEG27	34	-,X27,X35,X30		7	SEG4	SEG4
SEG31	SEG28	35	-,X28,X36,X29		6	SEG3	SEG3
SEG44	SEG29	36	S1,S3,S4,S2		5	SEG2	SEG2
SEG45	SEG30	37	S6,-,-,S7		4	SEG1	SEG1
SEG46	SEG31	38	S5,-,-S8		3	SEG0	SEG0
COM3	COM3	39	COM4		2	COM0	COM0
	NC	40	NC		1	NC	

Legend: Unshaded cells indicate a perfect match between the PIM and the glass.
 Shaded cells indicate the pins that are remapped to the corresponding pin on the PIM.

FIGURE A-6: SEGMENT CONFIGURATION FOR PIC18F87J90 DEVICES

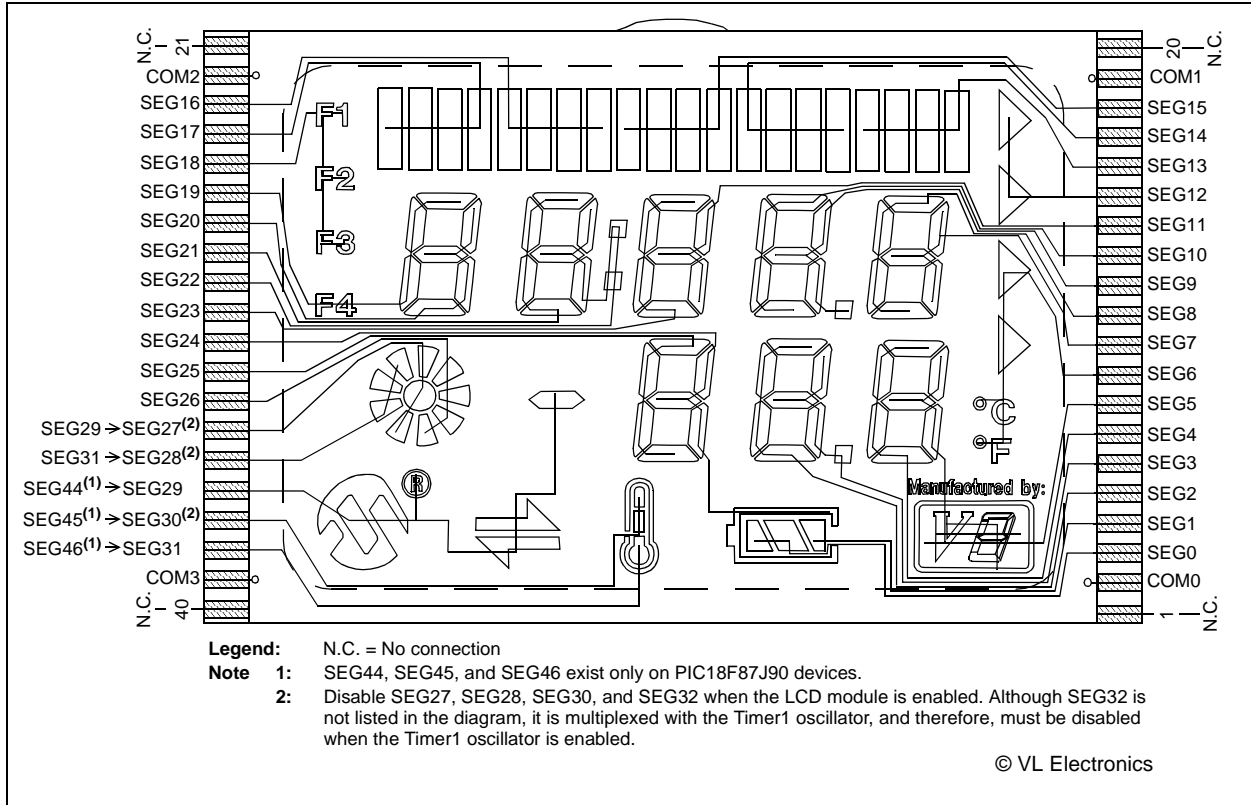

TABLE A-9: PIC18F87J90 PORT AND PIN COMPARISON

PIC18F87J90 Port	PIC18F87J90 PIN	ICE Pin	ICE Port
RA0	AN0	AN0	RA0
RA6	OSC2	OSC2	RA6
RA7	OSC1	OSC1	RA7
RB0	RB0	RB0	RB0
RB5	SEG29	SEG27	RG3
RB6	RB6	RB6	RB6
RB7	RB7	RB7	RB7
RC0	T1OSC1	T1OSC0	RC0
RC1	T1OSC0	T1OSC1	RC1
RC3	SEG17	SEG17	RA3
RC4	SEG16	SEG16	RA2
RC6	TX/CK	TX/CK	RC6
RC7	RX/DT	RX/DT	RC7

Legend: Unshaded cells indicate a perfect match between the PIM and the glass.
Shaded cells indicate the pins that are remapped to the corresponding pin on the PIM.

PICDEM™ LCD 2 Demonstration Kit User's Guide

TABLE A-10: PIC18F8490 PIM AND ICE PORT/PIN COMPARISON

PIC18F8490 PIM Pin No.	PIC18F8490 Port	PIC18F8490 Pin	ICE Pin	ICE Port	ICE Pin No.	PIC18F8490 PIM Pin No.	PIC18F8490 Port	PIC18F8490 Pin	ICE Pin	ICE Port	ICE Pin No.
1	RH2	SEG45	SEG45	RH2	12	41	RJ6	SEG37	SEG37	RJ6	54
2	RH3	SEG44	SEG44	RH3	13	42	RJ7	SEG36	SEG36	RJ7	55
3	LCDBIAS2	LCDBIAS2	BIAS2	RE1	14	43	RC2	SEG13	SEG13	RC2	56
4	LCDBIAS1	LCDBIAS1	BIAS1	RE0	15	44	RC3	RC3	RC3	RC3	57
5	RG0	SEG30	SEG30	RG0	16	45	RC4	RC4	RC4	RC4	58
6	RG1	SEG29	SEG29	RG1	17	46	RC5	SEG12	SEG12	RC5	59
7	RG2	SEG28	SEG28	RG2	18	47	RB7	RB7	RB7	RB7	60
8	RG3	SEG27	SEG27	RG3	19	48	VDD	VDD	ICEVDD	VDD	61
9	RG5	MCLR	ICEMCLR	RG5	20	49	RA7	OSC1	OSC1	RA7	62
10	RG4	SEG26	SEG26	RG4	21	50	RA6	OSC2	OSC2	RA6	63
11	Vss	Vss	Vss	Vss	23	51	Vss	Vss	Vss	Vss	65
12	VDD	VDD	ICEVDD	VDD	24	52	RB6	RB6	RB6	RB6	66
13	RF7	SEG25	SEG25	RF7	25	53	RB5	RB5	RB5	RB5	67
14	RF6	SEG24	SEG24	RF6	26	54	RB4	SEG11	SEG11	RB4	68
15	RF5	SEG23	SEG23	RF5	27	55	RB3	SEG10	SEG10	RB3	69
16	RF4	SEG22	SEG22	RF4	28	56	RB2	SEG9	SEG9	RB2	70
17	RF3	SEG21	SEG21	RF3	29	57	RB1	SEG8	SEG8	RB1	71
18	RF2	SEG20	SEG20	RF2	30	58	RB0	RB0	RB0	RB0	72
19	RH7	SEG43	SEG43	RH7	31	59	RJ3	SEG35	SEG35	RJ3	73
20	RH6	SEG42	SEG42	RH6	32	60	RJ2	SEG34	SEG34	RJ2	74
21	RH5	SEG41	SEG41	RH5	33	61	RJ1	SEG33	SEG33	RJ1	75
22	RH4	SEG40	SEG40	RH4	34	62	RJ0	SEG32	SEG32	RJ0	76
23	RF1	SEG19	SEG19	RF1	35	63	RD7	SEG7	SEG7	RD7	77
24	RF0	SEG18	SEG18	RF0	36	64	RD6	SEG6	SEG6	RD6	78
25	AVDD	AVDD	ICEVDD	AVDD	37	65	RD5	SEG5	SEG5	RD5	79
26	AVss	AVss	AVss	AVss	38	66	RD4	SEG4	SEG4	RD4	80
27	RA3	SEG17	SEG17	RA3	39	67	RD3	SEG3	SEG3	RD3	81
28	RA2	SEG16	SEG16	RA2	40	68	RD2	SEG2	SEG2	RD2	82
29	RA1	AN1	AN1	RA1	41	69	RD1	SEG1	SEG1	RD1	83
30	RA0	AN0	AN0	RA0	42	70	Vss	Vss	Vss	Vss	84
31	Vss	Vss	Vss	Vss	44	71	VDD	VDD	VDD	VDD	2
32	VDD	VDD	ICEVDD	VDD	45	72	RD0	SEG0	SEG0	RD0	3
33	RA5	SEG15	SEG15	RA5	46	73	RE7	SEG31	SEG31	RE7	4
34	RA4	SEG14	SEG14	RA4	47	74	RE6	COM3	COM3	RE6	5
35	RC1	TIOSC0	TIOSC1	RC1	48	75	RE5	COM2	COM2	RE5	6
36	RC0	T1OSC1	T1OSC0	RC0	49	76	RE4	COM1	COM1	RE4	7
37	RC6	TX/CK	TX/CK	RC6	50	77	COM0	COM0	COM0	RE3	8
38	RC7	RX/DT	RX/DT	RC7	51	78	LCDBIAS3	LCDBIAS3	BIAS3	RE2	9
39	RJ4	SEG39	SEG39	RJ4	52	79	RH0	SEG47	SEG47	RH0	10
40	RJ5	SEG38	SEG38	RJ5	53	80	RH1	SEG46	SEG46	RH1	11

TABLE A-11: PIC18F8490 LCD CONNECTIONS COMPARISON

PIC18F8490	ICE	Pin #			Pin #	ICE	PIC18F8490
	NC	21	NC		20	NC	
COM2	COM2	22	COM3		19	COM1	COM1
SEG16	SEG16	23	X8,X6,X5,X7		18	SEG15	SEG15
SEG17	SEG17	24	X1,X3,X4,X2		17	SEG14	SEG14
SEG18	SEG18	25	-,F2,F1,F3		16	SEG13	SEG13
SEG19	SEG19	26	1A,1E,F4,1F		15	SEG12	SEG12
SEG20	SEG20	27	1B,1C,1D,1G		14	SEG11	SEG11
SEG21	SEG21	28	2A,2E,2D,2F		13	SEG10	SEG10
SEG22	SEG22	29	2B,2C,COL,2G		12	SEG9	SEG9
SEG23	SEG23	30	3A,3E,3D,3F		11	SEG8	SEG8
SEG24	SEG24	31	S9,6G,6B,6C		10	SEG7	SEG7
SEG25	SEG25	32	6D,6F,6A,6E		9	SEG6	SEG6
SEG26	SEG26	33	X31,X33,X34,X32		8	SEG5	SEG5
SEG27	SEG27	34	-,X27,X35,X30		7	SEG4	SEG4
SEG28	SEG28	35	-,X28,X36,X29		6	SEG3	SEG3
SEG29	SEG29	36	S1,S3,S4,S2		5	SEG2	SEG2
SEG30	SEG30	37	S6,-,-,S7		4	SEG1	SEG1
SEG31	SEG31	38	S5,-,-,S8		3	SEG0	SEG0
COM3	COM3	39	COM4		2	COM0	COM0
	NC	40	NC		1	NC	

FIGURE A-7: SEGMENT CONFIGURATION FOR PIC18F8490 DEVICES

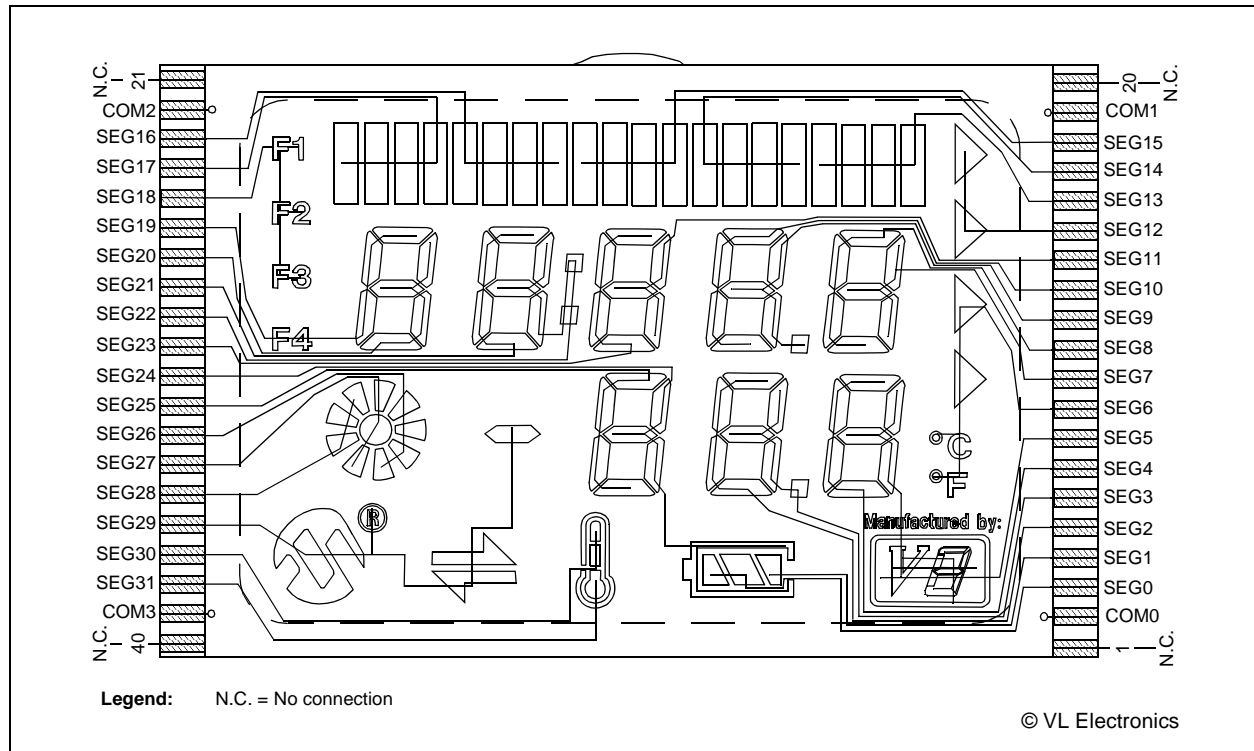

PICDEM™ LCD 2 Demonstration Kit User's Guide

TABLE A-12: PIC18F8490 PIN AND PORT COMPARISON

PIC18F8490 Port	PIC18F8490 Pin	ICE Pin	ICE Port
RA0	AN0	AN0	RA0
RA1	AN1	AN1	RA1
RA6	OSC2	OSC2	RA6
RA7	OSC1	OSC1	RA7
RB0	RB0	RB0	RB0
RB5	RB5	RB5	RB5
RB6	RB6	RB6	RB6
RB7	RB7	RB7	RB7
RC0	T1OSC1	T1OSC0	RC0
RC1	T1OSC0	T1OSC1	RC1
RC3	RC3	RC3	RC3
RC4	RC4	RC4	RC4
RC6	TX/CK	TX/CK	RC6
RC7	RX/DT	RX/DT	RC7

TABLE A-13: PIC16F946 PIM AND ICE PIN/PORT COMPARISON

PIC16F946 PIM Pin No.	PIC16F946 Port	PIC16F946 Pin	ICE Pin	ICE Port	ICE Pin No.	PIC16F946 PIM Pin No.	PIC16F946 Port	PIC16F946 Pin	ICE Pin	ICE Port	ICE Pin No.
1	RD6	SEG19	SEG19	RF1	35	33	RE0	SEG21	SEG21	RF3	29
2	RD7	SEG20	SEG20	RF2	30	34	RE1	SEG22	SEG22	RF4	28
3	RG0	SEG36	SEG36	RB1	71	35	RE2	SEG23	SEG23	RF5	27
4	RG1	SEG37	SEG37	RB2	70	36	ICEMCLR	ICEMCLR	ICEMCLR	ICEMCLR	20
5	RG2	SEG38	SEG38	RJ5	53	37	RE4	SEG24	SEG24	RF6	26
6	RG3	SEG39	SEG39	RJ4	52	38	ICEVDD	ICEVDD	ICEVDD	ICEVDD	61
7	RG4	SEG40	SEG40	RH4	34	39	RA7	T1OSCI	T1OSCI	RC1	48
8	RG5	SEG41	SEG41	RH5	33	40	RA6	T1OSCO	T1OSCO	RC0	49
9	Vss	Vss	Vss	Vss	23	41	Vss	Vss	Vss	Vss	65
10	VDD	VDD	ICEVDD	ICEVDD	24	42	RE5	SEG25	SEG25	RF7	25
11	RF0	SEG32	SEG32	RJ0	76	43	RE6	SEG26	SEG26	RG4	21
12	RF1	SEG33	SEG33	RD0	3	44	RE7	SEG27	SEG27	RG3	19
13	RF2	SEG34	SEG34	RD6	78	45	RE4	SEG28	SEG28	RG2	18
14	RF3	SEG35	SEG35	RD7	77	46	RF5	SEG29	SEG29	RG1	17
15	RB0	RB0	RB0	RB0	72	47	RF6	SEG30	SEG30	RG0	16
16	RB1	SEG1	SEG1	RD1	83	48	RF7	SEG31	SEG31	RE7	4
17	RB2	SEG2	SEG2	RD2	82	49	RC0	VLCD1	BIAS1	RE0	15
18	RB3	SEG3	SEG3	RD3	81	50	RC1	VLCD2	BIAS2	RE1	14
19	VDD	VDD	ICEVDD	ICEVDD	37	51	RC2	VLCD3	BIAS3	RE2	9
20	Vss	Vss	Vss	AVss	38	52	RC3	RC3	VLCAP1	RC3	57
21	RB4	COM0	COM0	RE3	8	53	RD0	COM3	COM3	RE6	5
22	RB5	COM1	COM1	RE4	7	54	RD1	NC	NC		
23	RB6	RB6	RB6	RB6	66	55	RD2	NC	NC		
24	RB7	RB7	RB7	RB7	60	56	Vss	Vss	Vss	Vss	1
25	AVDD	AVDD	ICEVDD	ICEVDD	45	57	VDD	VDD	VDD	VDD	2
26	AVss	AVss	AVss	AVss	44	58	RD3	SEG16	SEG16	RA2	40
27	RA0	AN0	AN0	RA0	42	59	RC4	RC4	RC4	VLCAP1\ RC4	58
28	RA1	AN1	AN1	RA1	41	60	RC5	SEG10	SEG10	RB3	69
29	RA2	COM2	COM2	RE5	6	61	RC6	TX/CK	TX/CK	TX/CK	50
30	RA3	SEG15	SEG15	RA5	46	62	RC7	RX/DT	RX/DT	RX/DT	51
31	RA4	SEG4	SEG4	RD4	80	63	RD4	SEG17	SEG17	RA3	39
32	RA5	SEG5	SEG5	RD5	79	64	RD5	SEG18	SEG18	RF0	36

Legend: Unshaded cells indicate where a perfect match between PIM and ICE pins and ports exists.
 Shaded cells indicate where differences between PIM and ICE ports and pins exist.
Bold text indicates the PIM pins that are not connected to any ICE pins or ports.

PICDEM™ LCD 2 Demonstration Kit User's Guide

TABLE A-14: PIC16F946 LCD CONNECTIONS COMPARISON

PIC16F946	ICE	Pin #			Pin #	ICE	PIC16F946
	NC	21	NC		20	NC	
COM2	COM2	22	COM3		19	COM1	COM1
SEG16	SEG16	23	X8,X6,X5,X7		18	SEG15	SEG15
SEG17	SEG17	24	X1,X3,X4,X2		17	SEG14	SEG41
SEG18	SEG18	25	-,F2,F1,F3		16	SEG13	SEG40
SEG19	SEG19	26	1A,1E,F4,1F		15	SEG12	SEG39
SEG20	SEG20	27	1B,1C,1D,1G		14	SEG11	SEG38
SEG21	SEG21	28	2A,2E,2D,2F		13	SEG10	SEG10
SEG22	SEG22	29	2B,2C,COL,2G		12	SEG9	SEG37
SEG23	SEG23	30	3A,3E,3D,3F		11	SEG8	SEG36
SEG24	SEG24	31	S9,6G,6B,6C		10	SEG7	SEG35
SEG25	SEG25	32	6D,6F,6A,6E		9	SEG6	SEG34
SEG26	SEG26	33	X31,X33,X34,X32		8	SEG5	SEG5
SEG27	SEG27	34	-,X27,X35,X30		7	SEG4	SEG4
SEG28	SEG28	35	-,X28,X36,X29		6	SEG3	SEG3
SEG29	SEG29	36	S1,S3,S4,S2		5	SEG2	SEG2
SEG30	SEG30	37	S6,-,-,S7		4	SEG1	SEG1
SEG31	SEG31	38	S5,-,-S8		3	SEG0	SEG33
COM3	COM3	39	COM4		2	COM0	COM0
	NC	40	NC		1	NC	

Legend: Unshaded cells indicate a perfect match between the PIM and the glass.
 Shaded cells indicate the pins that are remapped to the corresponding pin on the PIM.

FIGURE A-8: SEGMENT CONFIGURATION FOR PIC16F946 DEVICES

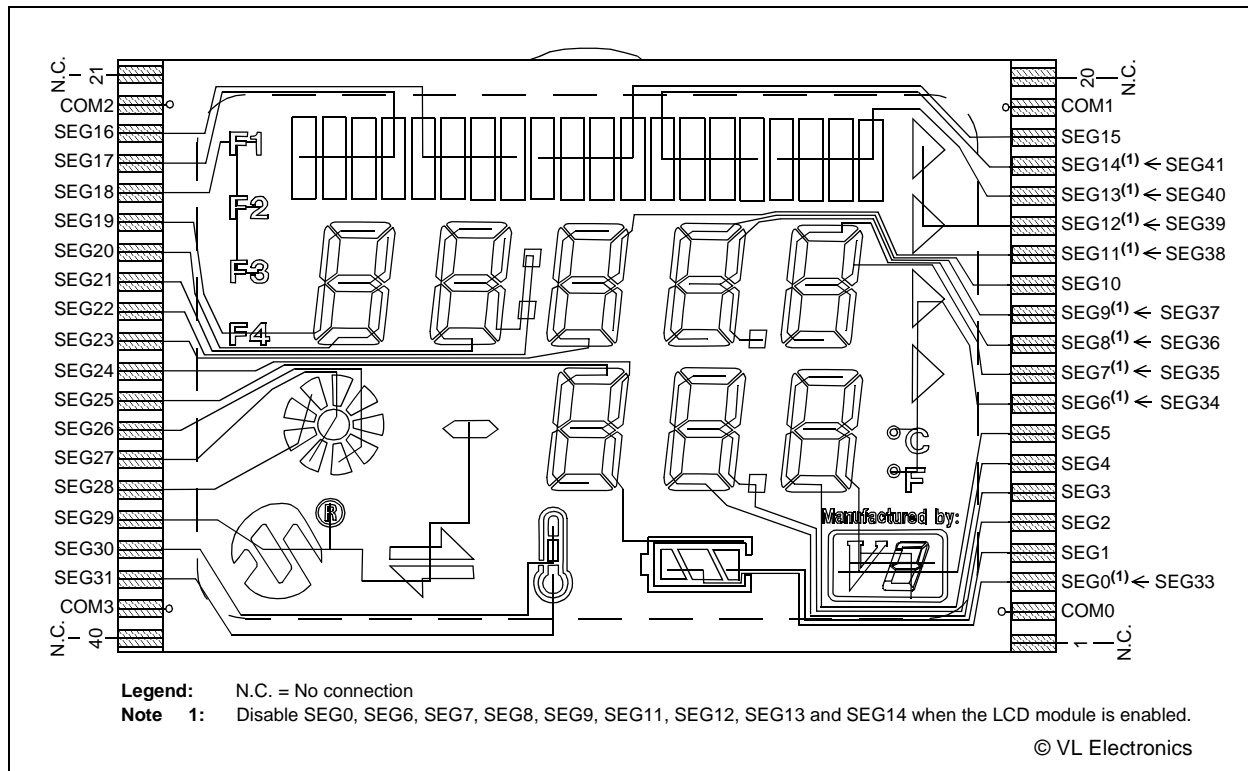

TABLE A-15: PIC16F946 PORT AND PIN COMPARISON

PIC16F946 Port	PIC16F946 Pin	ICE Pin	ICE Port
RA0	AN0	AN0	RA0
RA1	AN1	AN1	RA1
RA6	T1OSCO	T1OSCO	RC0
RA7	T1OSCI	T1OSCI	RC1
RB0	RB0	RB0	RB0
RB5	COM1	COM1	RE4
RB6	RB6	RB6	RB6
RB7	RB7	RB7	RB7
RC0	VLCD1	BIAS1	RE0
RC1	VLCD2	BIAS2	RE1
RC3	RC3	RC3	RC3
RC4	RC4	RC4	RC4
RC6	TX/CK	TX/CK	RC6
RC7	RX/DT	RX/DT	RC7

Legend: Unshaded cells indicate a perfect match between the PIM and the glass.
Shaded cells indicate the pins that are remapped to the corresponding pin/port on the PIM.

PICDEM™ LCD 2 Demonstration Kit User's Guide

TABLE A-16: PIC16F917 PIM AND ICE PIN/PORT COMPARISON

PIC16F917 PIM Pin No.	PIC16F917 Port	PIC16F917 Pin	ICE Pin	ICE Port	ICE Pin No.
1	RC7	RX/DT	RX/DT	RC7	51
2	RD4	SEG17	SEG17	RA3	17
3	RD5	SEG18	SEG18	RF0	18
4	RD6	SEG19	SEG19	RF1	19
5	RD7	SEG20	SEG20	RF2	20
6	Vss	Vss	Vss	Vss	Vss
7	VDD	ICEVDD	ICEVDD	VDD	45
8	RB0	RB0	RB0	RB0	72
9	RB1	SEG1	SEG6	RD6	78
10	RB2	SEG2	SEG7	RD7	77
11	RB3	SEG3	SEG8	RB1	71
14	RB4	COM0	COM0	RE3	8
15	RB5	COM1	COM1	RE4	7
16	RB6	RB6	RB6	RB6	66
17	RB7	RB7	RB7	RB7	60
18	ICEMCLR	ICEMCLR	ICEMCLR	ICEMCLR	20
19	RA0	AN0	AN0	RA0	42
20	RA1	AN1	AN1	RA1	41
21	RA2	COM2	COM2	RE5	6
22	RA3	SEG15	SEG15	RA5	15
23	RA4	SEG4	SEG9	RB2	4
24	RA5	SEG5	SEG10	RB3	5
25	RE0	SEG21	SEG21	RF3	21
26	RE1	SEG22	SEG22	RF4	22
27	RE2	SEG23	SEG23	RF5	23
28	VDD	ICEVDD2	ICEVDD	VDD	2
29	Vss	Vss	Vss	Vss	Vss
30	RA7	T1OSCI	T1OSCI	RC1	48
31	RA6	T1OSCO	T1OSCO	RC0	49
32	RC0	VLCD1	BIAS1	RE0	15
35	RC1	VLCD2	BIAS2	RE1	14
36	RC2	VLCD3	BIAS3	RE2	9
37	RC3	SEG6	SEG11	RB4	68
38	RD0	COM3	COM3	RE6	5
39	RD1	RD1	RC3	RC3	57
40	RD2	RD2	RC4	RC4	58
41	RD3	SEG16	SEG16	RA2	16
42	RC4	SEG11	SEG14	RA4	47
43	RC5	SEG10	SEG13	RC2	56
44	RC6	TX/CK	TX/CK	RC6	50

Legend: Unshaded cells indicate where a perfect match between PIM and ICE pins and ports exists.
 Shaded cells indicate where differences between PIM and ICE ports and pins exist.
Bold text indicates the PIM pins that are not connected to any ICE pins or ports.

TABLE A-17: PIC16F917 LCD CONNECTIONS COMPARISON

PIC16F917	ICE	Pin #			Pin #	ICE	PIC16F917
	NC	21	NC		NC	20	NC
COM2	COM2	22	COM3		COM2	19	COM1
SEG16	SEG16	23	X8,X6,X5,X7		X9,X11,X12,X10	18	SEG15
SEG17	SEG17	24	X1,X3,X4,X2		X16,X14,X13,X15	17	SEG14
SEG18	SEG18	25	-,F2,F1,F3		X17,X19,X20,X18	16	SEG13
SEG19	SEG19	26	1A,1E,F4,1F		-,X22,X21,-	15	SEG12
SEG20	SEG20	27	1B,1C,1D,1G		3B,3C,-,3G	14	SEG11
SEG21	SEG21	28	2A,2E,2D,2F		4A,4E,4D,4F	13	SEG10
SEG22	SEG22	29	2B,2C,COL,2G		4B,4C,DP1,4G	12	SEG9
SEG23	SEG23	30	3A,3E,3D,3F		5A,5E,5D,5F	11	SEG8
NC	SEG24	31	S9,6G,6B,6C		5B,5C,-,5G	10	SEG7
NC	SEG25	32	6D,6F,6A,6E		X23,X25,X26,X24	9	SEG6
NC	SEG26	33	X31,X33,X34,X32		S13,8G,8B,8C	8	SEG5
NC	SEG27	34	-,X27,X35,X30		8D,8F,8A,8E	7	SEG4
NC	SEG28	35	-,X28,X36,X29		DP2,7G,7B,7C	6	SEG3
NC	SEG29	36	S1,S3,S4,S2		7D,7F,7A,7E	5	SEG2
NC	SEG30	37	S6,-,-,S7		S11,-,-,-	4	SEG1
NC	SEG31	38	S5,-,-S8		S12,-,-,S10	3	SEG0
COM3	COM3	39	COM4		COM1	2	COM0
	NC	40	NC		NC	1	NC

Legend: Unshaded cells indicate a perfect match between the PIM and the glass.
 Shaded cells indicate the pins that are remapped to the corresponding pin on the PIM.
Bold text indicates the PIM pins that are not connected.

FIGURE A-9: SEGMENT CONFIGURATION FOR PIC16F914/917 DEVICES

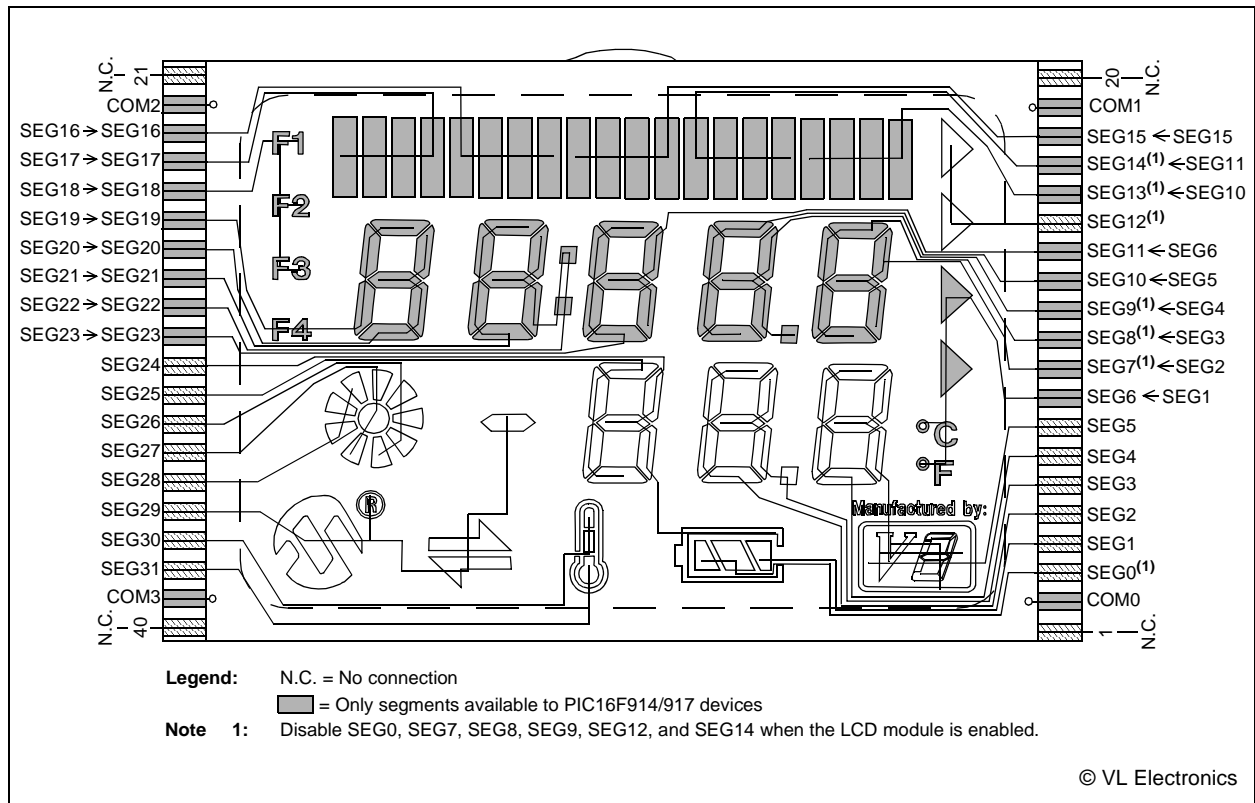

PICDEM™ LCD 2 Demonstration Kit User's Guide

TABLE A-18: PIC16F917 PIN AND PORT COMPARISON

PIC16F917 Port	PIC16F917 Pin	ICE Pin	ICE Port
RA0	AN0	AN0	RA0
RA1	AN1	AN1	RA1
RA6	T1OSCO	T1OSCO	RC0
RA7	T1OSCI	T1OSCI	RC1
RB0	RB0	RB0	RB0
RB5	COM1	COM1	RE4
RB6	RB6	RB6	RB6
RB7	RB7	RB7	RB7
RC0	VLCD1	BIAS1	RE0
RC1	VLCD2	BIAS2	RE1
RC3	SEG6	SEG11	RB4
RC4	SEG11	SEG14	RA4
RC6	TX/CK	TX/CK	RC6
RC7	RX/DT	RX/DT	RC7

Legend: Unshaded cells indicate a perfect match between the PIM and the glass.
Shaded cells indicate the pins that are remapped to the corresponding pin on the PIM.

A.3 LED DISPLAY

Two green LEDs are connected to RC3 and RC4 of U1A through the J14 pins, 1, 2 and 7, 8 (outer ends), respectively.

One green LED is provided to determine whether there is power to the LCD 2 Demonstration Board (LED on) or not (LED off).

- Note 1:** For the PIC18F85J90 and PIC18F87J90 PIM, the RG2 and RG3 pins are connected to RC3 and RC4 of U1A, respectively.
- 2:** For the PIC16F17 PIM, the RD1 and RD2 pins are connected to RC3 and RC4 of U1A, respectively.
- 3:** For the PIC18F8490 PIM, the RC3 and RD4 pins are connected to RC3 and RC4 of U1A, respectively

A.4 CHARGE PUMP AND VLCAP

For charge pump mode operation in PIC18F85J90 and PIC18F87J90 devices, it is required that RC3 and RC4 of U1A connect to charge pump capacitor C7 through the J14 pins, 3, 4 and 5, 6 (inner pins), respectively.

A.5 RESISTIVE LADDER VERSUS CHARGE PUMP

The switch, S6, allows the connection of either the resistor ladder or the capacitors to the BIAS pins to generate the BIAS voltages for the LCD operation. For the charge pump mode operation in PIC18F85J90 and PIC18F87J90 devices, it is required that the S6 switch is flipped towards C and the VLCAP is connected through the inner jumpers of J14. For the resistor ladder, S6 must be flipped towards R. The R45 potentiometer controls the contrast to the LCD in the Resistive Ladder mode.

A.5.1 Jumper JP21

When jumper JP21 is on, the LCDBIAS0 is physically tied to ground. The jumper needs to be on for PIC18F85J90 and PIC18F87J90 devices when the bias voltages are generated through the resistor ladder.

A.6 OSCILLATOR OPTIONS

The on-board firmware uses the internal RC oscillator running at 8 MHz.

- Internal RC oscillator running at 8 MHz can be used.
- Pads provided for user-furnished crystal/resonator (Y2) and two capacitors (C16 and C17).
- Socket provided for a canned oscillator (Y3). This oscillator can be disabled by removing jumpers, JP9, JP11 and JP12.
- 32.768 kHz (watch-type) crystal for Timer1 (Y1) is always connected to RC0 and RC1.

A.7 RS-232 SERIAL PORT

An RS-232 level shifting IC has been provided with all necessary hardware to support connection of an RS-232 host through the DB9 connector (PI). The port is configured as DCE and can be connected to a PC using a serial cable.

A.8 REAL-TIME CLOCK

This circuit allows the user to configure a PIC microcontroller for timekeeping using a 32.768 kHz clock crystal connected to Timer1 module's T1OSO and T1OSI pins.

A.9 SERIAL EEPROM

A socket for a Microwire EEPROM is provided on the board to illustrate usage of the Synchronous mode of operation of the USART module. For its operation:

- Jumpers, JP15 and JP16, should be connected.
- In the jumper, J6, U9-CS should be connected with RB5.
- In the jumper, J13, U9-ORG (pin 6) should be connected to GND.

- | |
|--|
| <p>Note 1: For the PIC18F85J90 and PIC18F87J90 PIM, the RG2 and RG3 pins are connected to RC3 and RC4 of U1A, respectively.</p> <p>2: For the PIC16F917 PIM, the RD1 and RD2 pins are connected to RC3 and RC4 of U1A, respectively.</p> <p>3: For the PIC18F8490 and the PIC16F946 PIMs, the RC3 and RC4 pins are connected to RC3 and RC4 of U1A, respectively.</p> |
|--|

A.10 ANALOG INPUT

A 10 k Ω potentiometer is connected through a series of 100 Ω resistors to AN0. The potentiometer can be adjusted from VCC to GND. The jumper, J11, should be connecting the potentiometer to AN0.

PICDEM™ LCD 2 Demonstration Kit User's Guide

A.11 TEMPERATURE SENSOR

A 10 k Ω TC thermistor (R11) is provided to sense the temperature. It is connected to AN1 (RA1) through the jumper, JP5. An optional unpopulated TC77-based circuit is provided to read the temperature serially using the USART module. The jumpers, JP15 and JP16, are to be connected and RA1 of U1A should be made digital to be used to enable TC77.

- Note 1:** For the PIC18F85J90 and PIC18F87J90 PIM, the RA2 pin is connected to RA1 of U1A and AN2 is used instead of AN1.
- 2:** For the PIC18F8490, PIC16F946, and PIC16F917 PIMs, the RA1 pin is connected to RA1 of U1A.

A.12 SWITCHES

Four switches provide the following functions for digital I/Os:

- S1 – Active-low switch connected to RB6.
- S2 – Active-low switch connected to RB6 and RB7.
- S3 – Active-low switch connected to RB6, RB7 and RA6.
- S4 – Active-low switch connected to RB6, RB7, RA6 and RA7.

For this type of sensing, the jumpers, JP1, JP2, JP6, JP18, JP19, JP9 and JP10, should be connected and the potentiometer should be connected to AN0 through J11. Sensing should be done in the sequence, S1, S2, S3 and S4, only. Individual switch sensing is not allowed.

Additionally, the four switches provide the following functions for analog input (AN0):

- S1 – AN0 will be approximately at $V_{CC}/2$.
- S2 – AN0 will be approximately at $V_{CC}/3$.
- S3 – AN0 will be approximately at $V_{CC}/5.2$.
- S4 – AN0 will be approximately at $V_{CC}/7.7$.

For this type of sensing, the jumpers, JP1, JP2, JP6, JP18 and JP19, should not be connected and the SWT should be connected to AN0 through J11.

A.13 ICD CONNECTOR

By way of the modular connector (J37), the MPLAB ICD 2 can be connected for low-cost debugging. The ICD connector utilizes RB6/PGC and RB7/PGD of the microcontrollers for in-circuit debugging.

A.14 POWER SUPPLY

There are four ways to supply power to the PICDEM LCD 2:

- A 3V button cell (CR2032) can be plugged into BT1.
- A 9V, 100 mA unregulated AC to DC supply can be plugged into J5. A power supply can be purchased through Microchip Technology (Part Number AC162039).
- A 100 mA regulated DC supply of maximum +5V can be connected to the hooks provided.

Note: There is one J15 jumper associated with the power supply circuit. This jumper must be correctly connected to select the required power supply. Refer to Figure A-10 for jumper setting examples.

MPLAB ICD 2 users may use the ICD to power the target board to 5V, up to 200 mA, for the following devices *only*: PIC18F8490, PIC16F946 and PIC16F916. The PIC18F85J90 and PIC18F87J90 families of devices do not support this capability.

The default power on the board is 5V. The board voltage can be varied based on resistors populated on the PIM in conjunction with the processor being used.

FIGURE A-10: J15 POWER SUPPLY CIRCUIT SETTING EXAMPLES

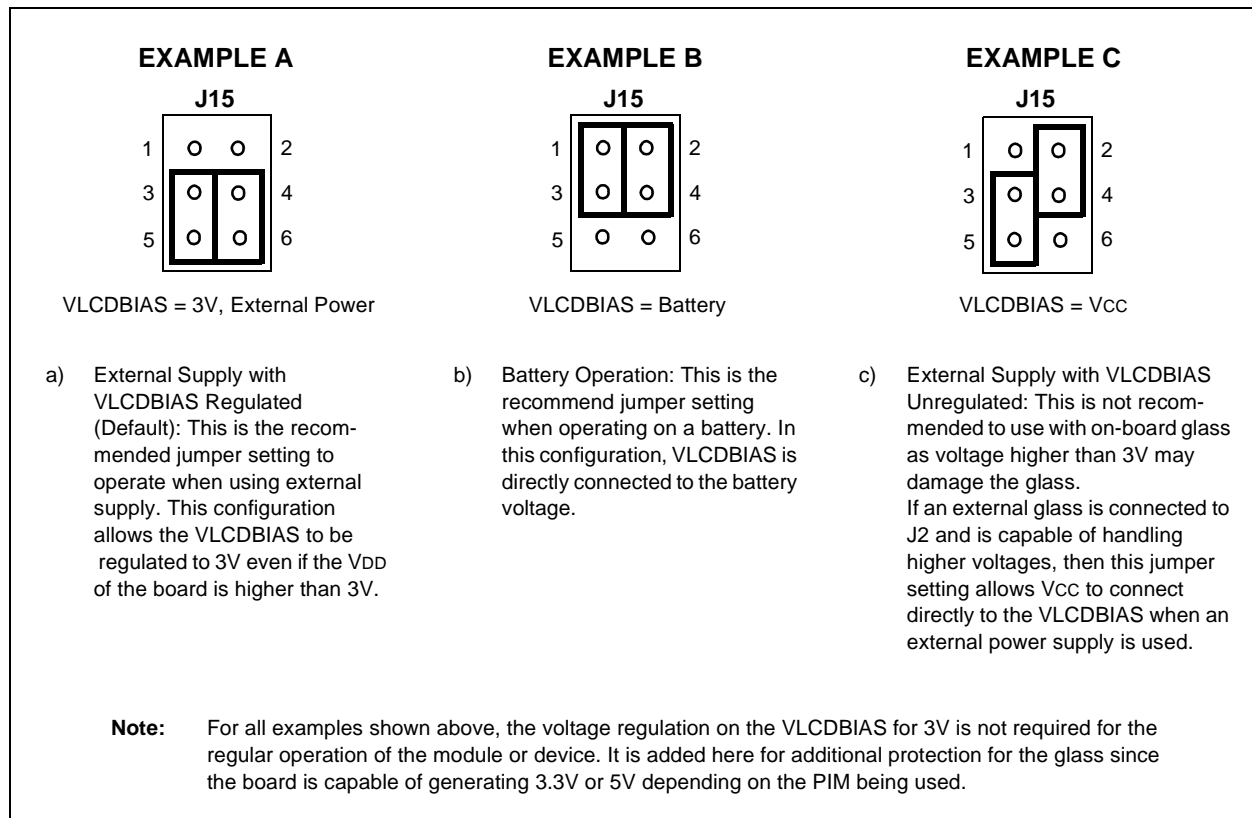

A.14.1 Using the Adjustable Voltage Regulator

The PICDEM LCD 2 board features an adjustable voltage regulator, the venerable LM317. It is U3 on the board, and can be recognized by the SO-223 package on the upper left side. Nearby, there is a header, J10, and two resistors, R25 and R26. R25 and R26 are used to set the output voltage of the LM317. By default, R25 = 1K and R26 = 330R, which results in an output voltage of 5.0V.

The reason an adjustable voltage regulator is provided is so that the PICDEM LCD 2 Demonstration Board can be used with a wide range of LCD PIC microcontrollers. The PIC18FXXJ90 family of devices tolerates a maximum V_{DD} of 3.6V, whereas the PIC18FXX90, PIC16F91X and PIC16F946 tolerate a maximum V_{DD} of 5.5V. The adjustable voltage regulator allows a different V_{DD} to be provided for PIC18FJ devices and PIC18F and PIC16F LCD devices.

The switching between 3.6V and 5.5V parts is very convenient. The plug-in module boards are populated with the R101 and R102, appropriately, according to the processor module requirement which mates with the daughterboard/emulator header that surrounds the ICE module (U1A). J10 on the PICDEM LCD 2 board is intended to connect with the 3-pin header on the plug-in module. This allows the resistors, R101 and R102, on the plug-in module to be connected in parallel to the resistors, R25 and R26. This way V_{DD} can automatically be adjusted to the voltage appropriate to the part soldered onto the plug-in module.

The plug-in module is prepopulated with the values shown in Table A-19:

TABLE A-19: PIM PREPOPULATED VALUES

Module	R101	R102	V _{DD}
PIC18F87J90	Open	1.18K	3.3V
PIC18F85J90	Open	1.18K	3.3V
PIC18F8490	Open	Open	5.0V
PIC16F914/917	Open	Open	5.0V
PIC16F946	Open	Open	5.0V

For V_{DD} = 3.3 volts, R101 can be left unpopulated and R102 can be 1.18K. (1% resistors are recommended for precise adjustment of V_{DD}.)

Now, let's look at how to determine R101 and R102 if a different V_{DD} is desired. First, it is a good idea to look at the data sheet for the LM317 to understand how the voltage is adjusted. We won't duplicate all the details here. The following equation is taken from an LM317 data sheet:

EQUATION A-1:

$$V_{OUT} = V_{REF} (1 + R2/R1) + I_{ADJ} * R2$$

I_{ADJ} is minimized by the LM317, so it can be assumed to be zero or at least very small. V_{REF} = 1.25V; it is the reference voltage developed by the LM317 between the output and adjustment terminal.

That gives us the following equation:

EQUATION A-2:

$$V_{OUT} = 1.25V(1 + R2/R1)$$

$$R2 = R25 \parallel R102 = (R25 * R102) / (R25 + R102)$$

$$R1 = R26 \parallel R101 = (R26 * R101) / (R26 + R101)$$

As stated previously, R25 = 1K and R26 = 330. You can see that without R102 and R101, V_{OUT} = 1.25V(1 + 1K/330R) = 5.04V.

For a desired V_{OUT} , first solve for R_2 , given $R_1 = R_{26} = 330R$. Then, knowing R_2 and R_{25} , solve for R_{102} . Determine the nearest available resistor value for R_{102} and recalculate the resulting V_{DD} to make sure it doesn't exceed the maximum V_{DD} for the part you will be using.

Table A-20 shows values for R_{101} and R_{102} for different V_{DD} values, assuming that R_{25} and R_{26} on the PICDEM LCD 2 Board are left as their default values of 1K and 330R.

TABLE A-20: R101 AND R102 V_{DD} VALUES

V_{DD}	R101	R102
5V	Open	Open
3.6V	Open	1.62K
3.3V	Open	1.18K
3.0V	Open	866R

Recommended operating voltages for the various PIMs are:

- PIC18F85J90 and PIC18F87J90 families of devices – 3.3V
- PIC18F8490 family of devices – 5V
- PIC16F917/914 devices – 5V
- PIC16F946 – 5V (when operating on an external 9V DC supply)

A.14.2 Slide Switch (S6)

The slide switch allows choosing the BIAS values, either generated by the resistor ladder, or by the capacitive charge pump. When S6 is switched to the left, the LCDBIAS pins of the microcontroller are connected to the resistor ladder. When S6 is switched to the right, the LCDBIAS pins of the microcontroller are connected to the capacitor network.

PICDEM™ LCD 2 Demonstration Kit User's Guide

A.15 BOARD LAYOUT AND SCHEMATICS

The following figures show the parts layout (silkscreen) and schematics for the PICDEM LCD 2 board.

FIGURE A-11: PICDEM™ LCD 2 DEMONSTRATION BOARD PARTS LAYOUT (SILKSCREEN)

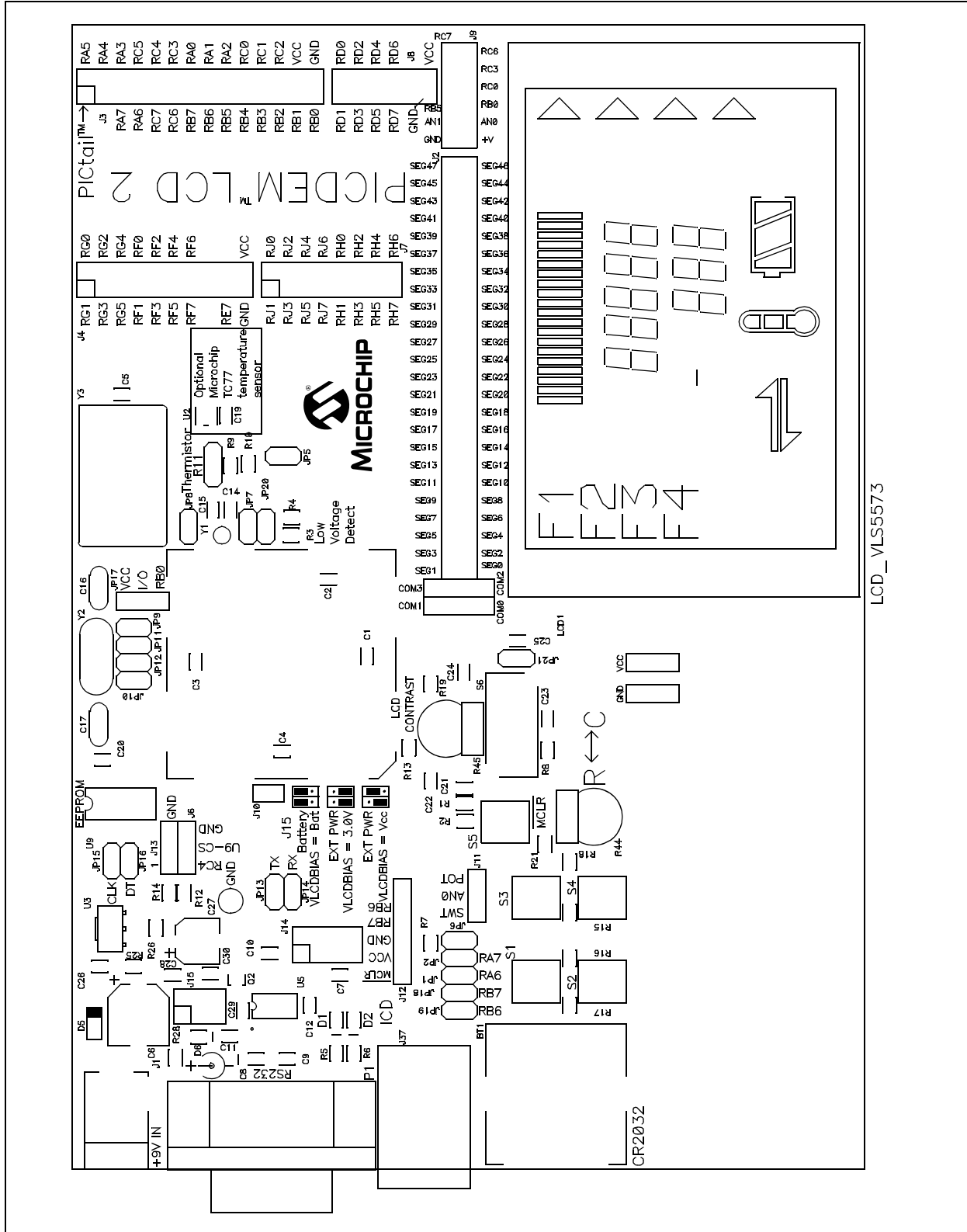
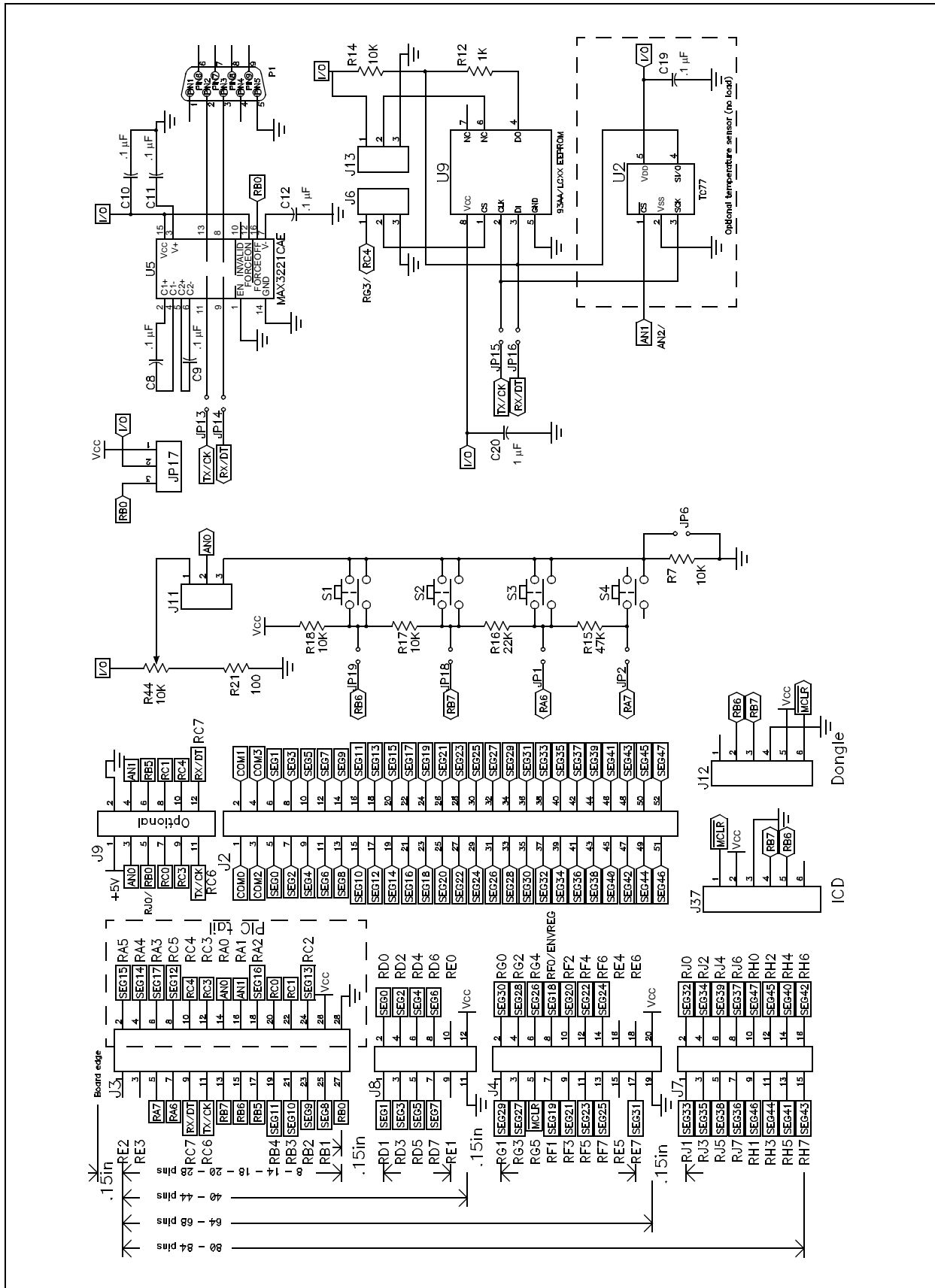

FIGURE A-12: PICDEM™ LCD 2 SCHEMATIC SHEET 1 OF 3



PICDEM™ LCD 2 Demonstration Kit User's Guide

FIGURE A-13: PICDEM™ LCD 2 SCHEMATIC SHEET 2 OF 3

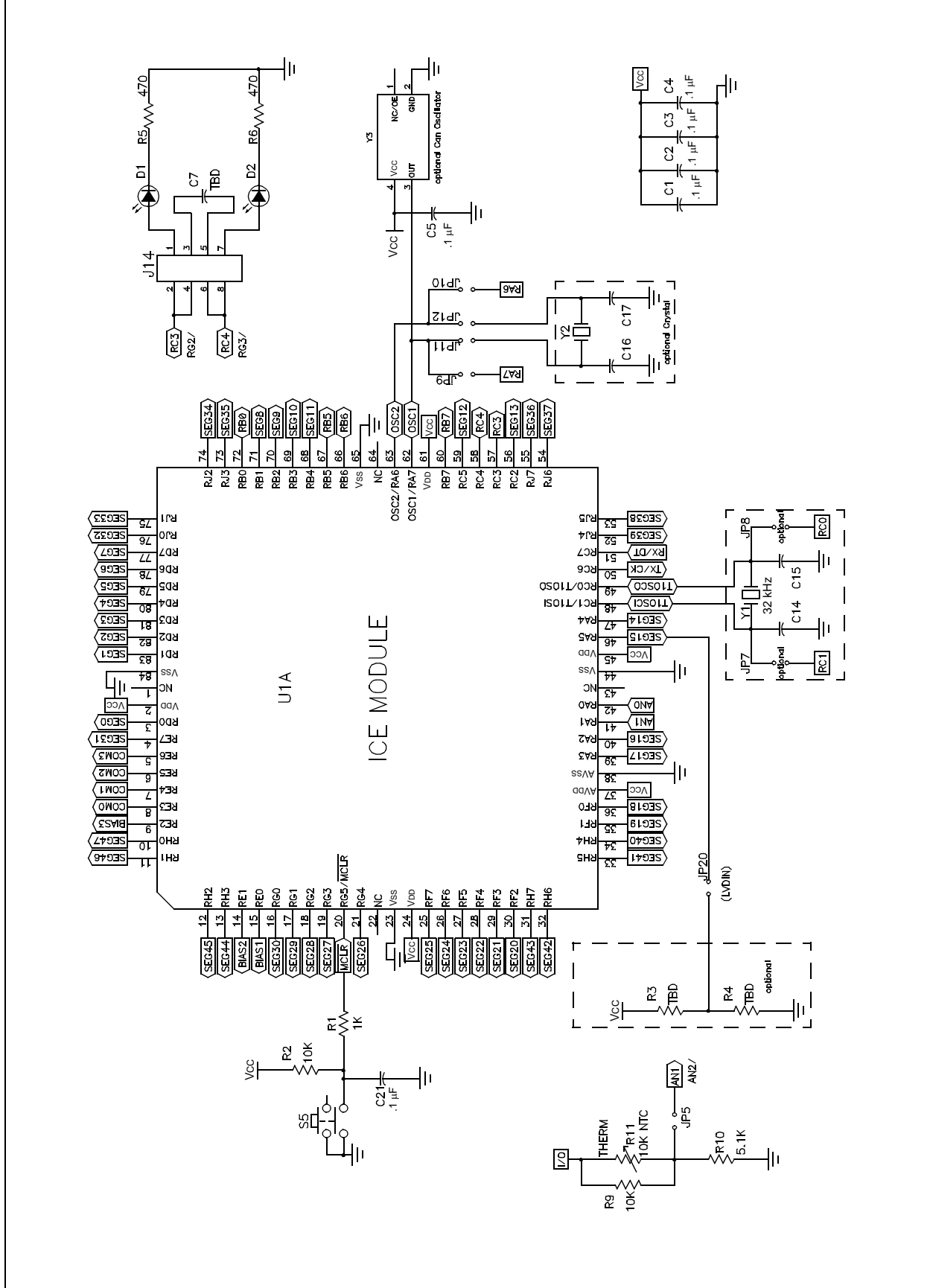
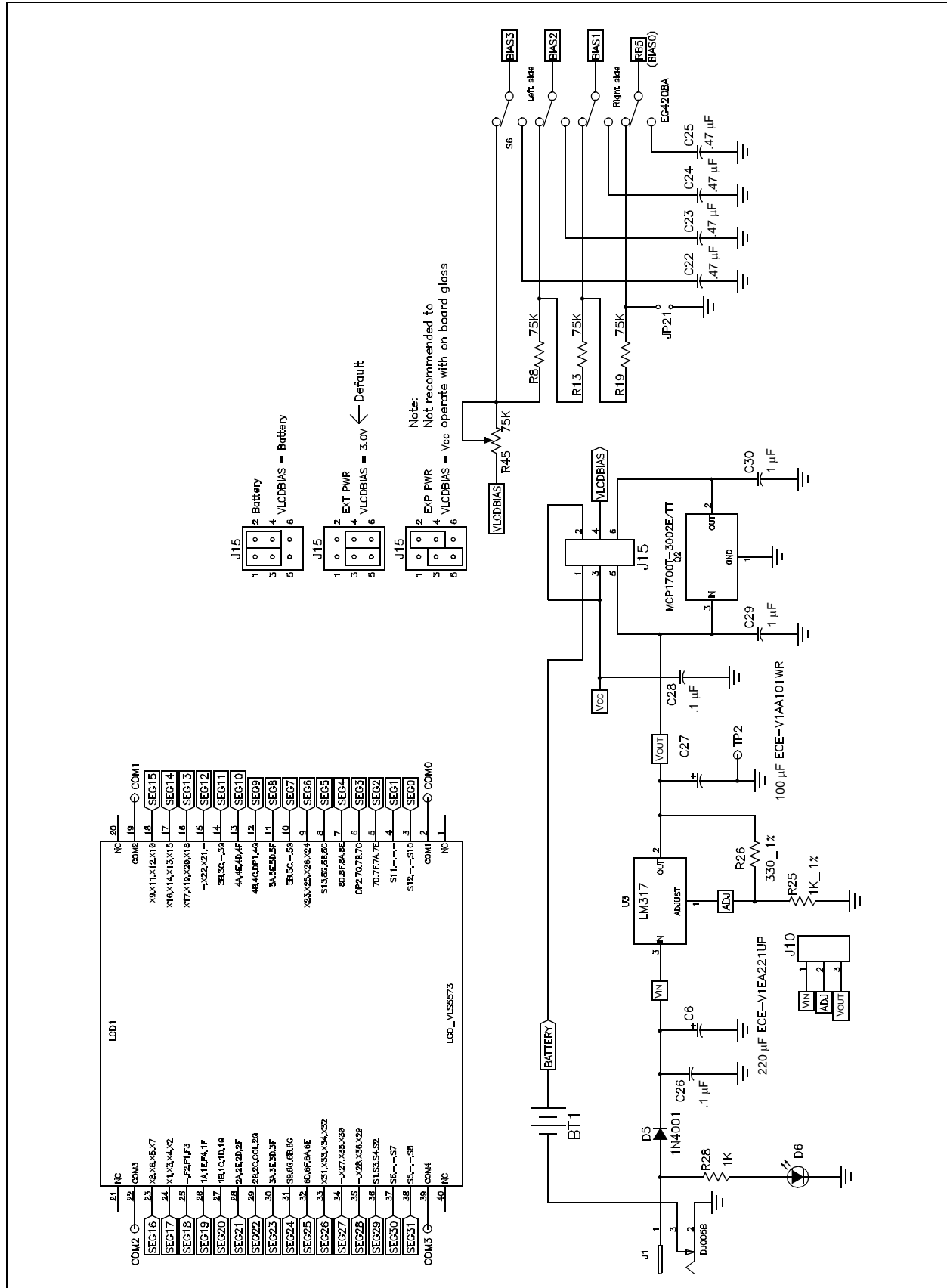

FIGURE A-14: PICDEM™ LCD 2 SCHEMATIC SHEET 3 OF 3



PICDEM™ LCD 2 Demonstration Kit User's Guide

A.16 PIM LAYOUT AND SCHEMATICS

The following figures show the layout (silkscreen) for the individual PIMs.

FIGURE A-15: PIC18F65J90 AND PIC18F85J90 PIM LAYOUT

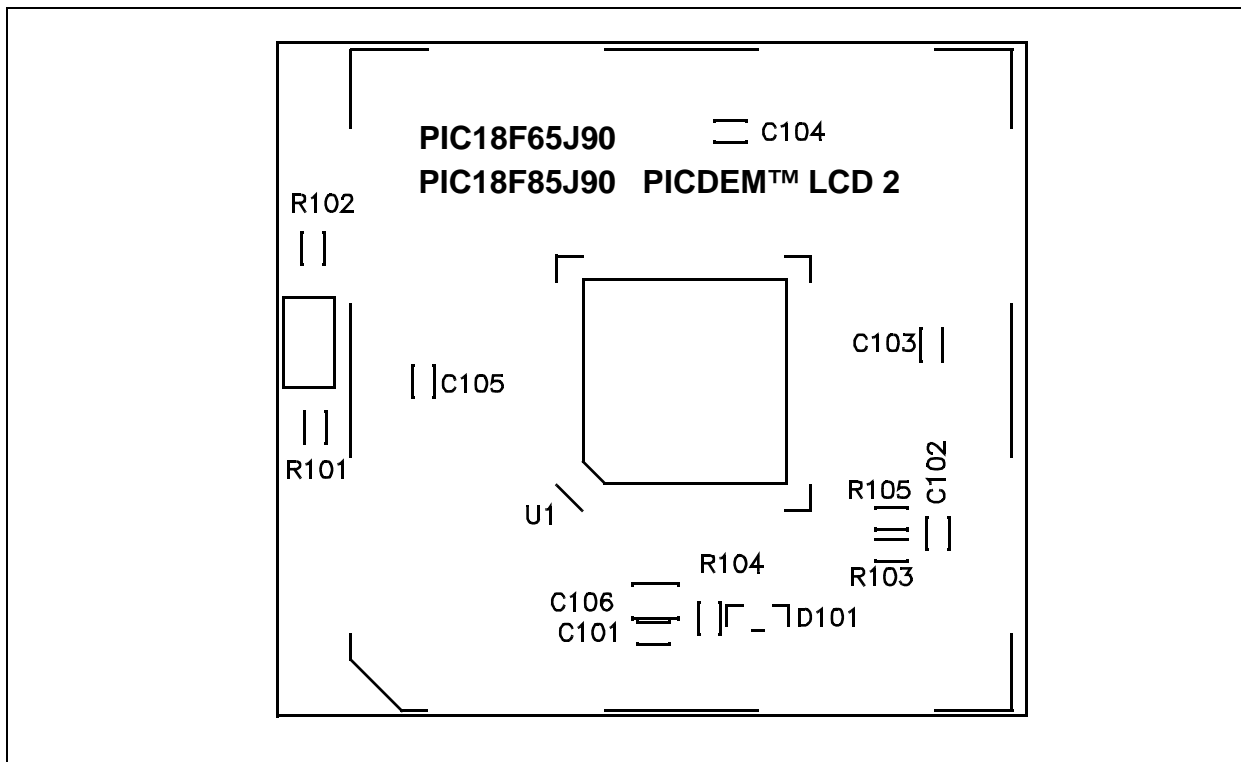

FIGURE A-16: PIC16F914/917 PIM LAYOUT

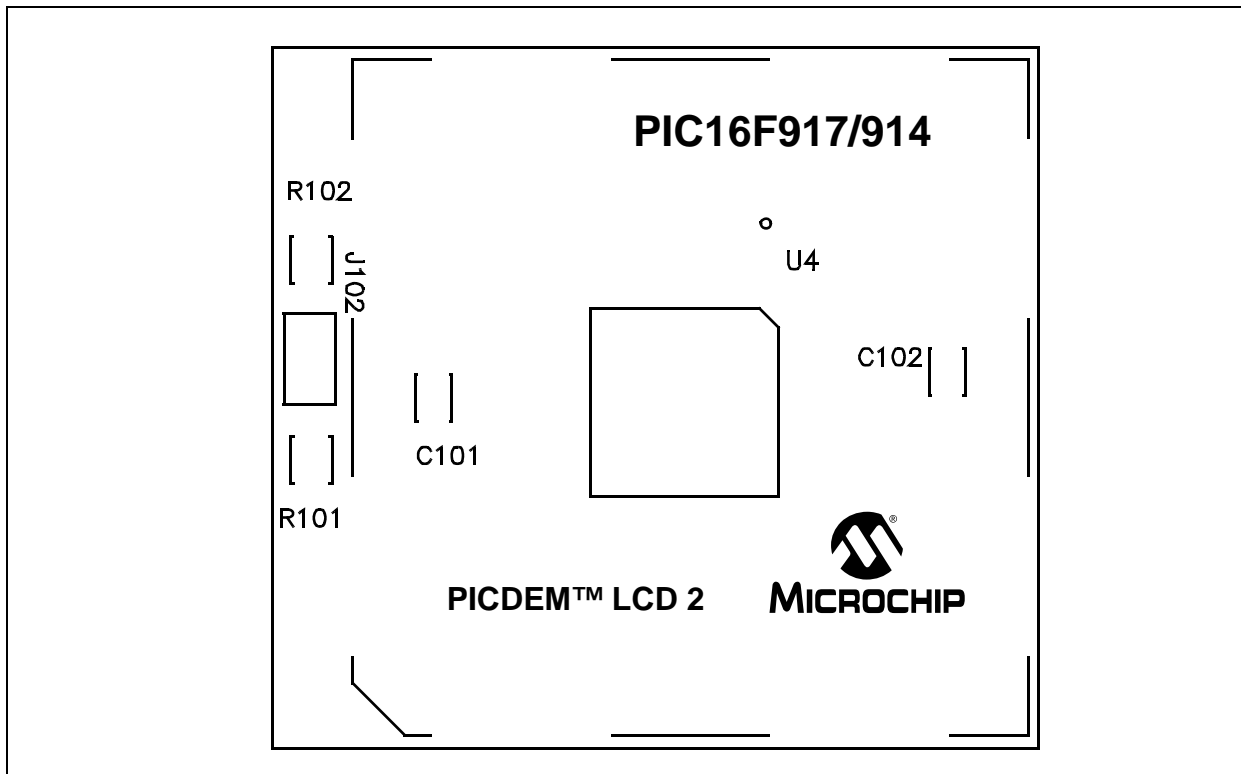

FIGURE A-17: PIC16F946 PIM LAYOUT

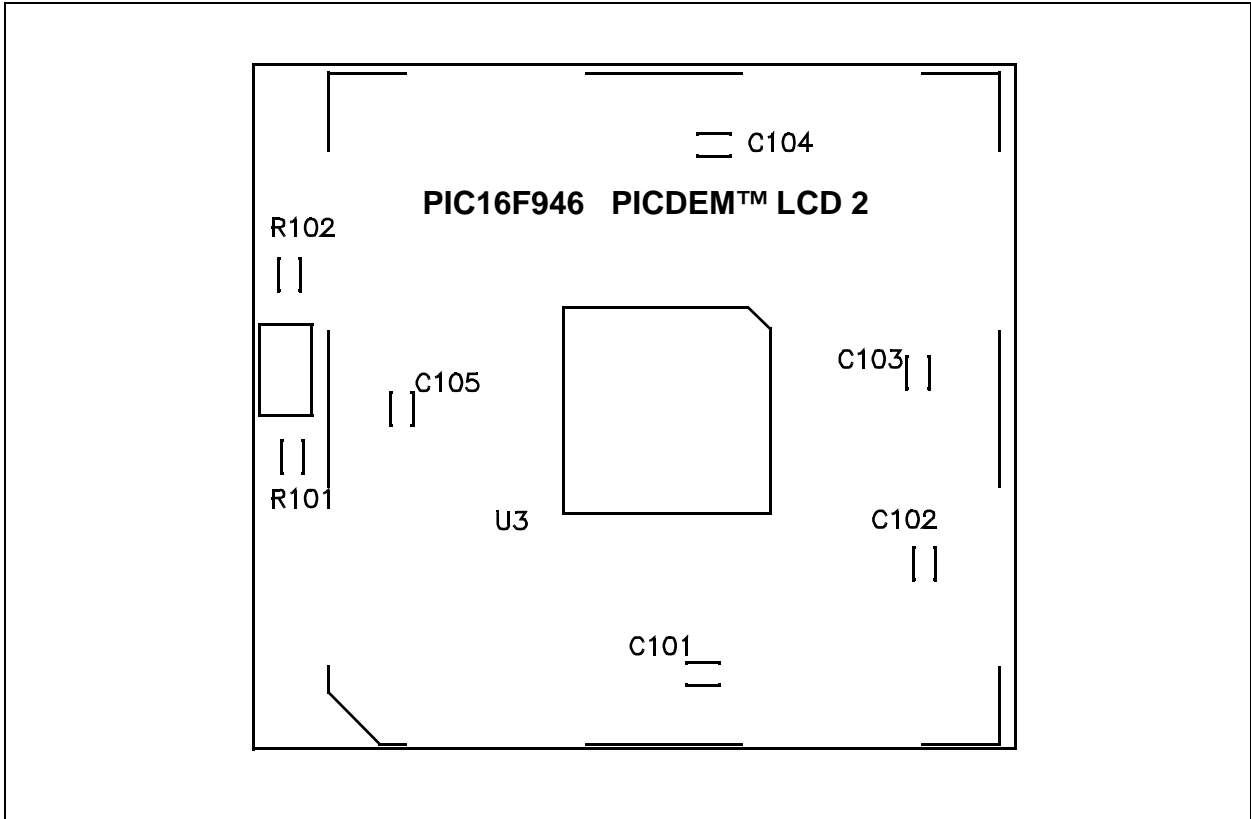
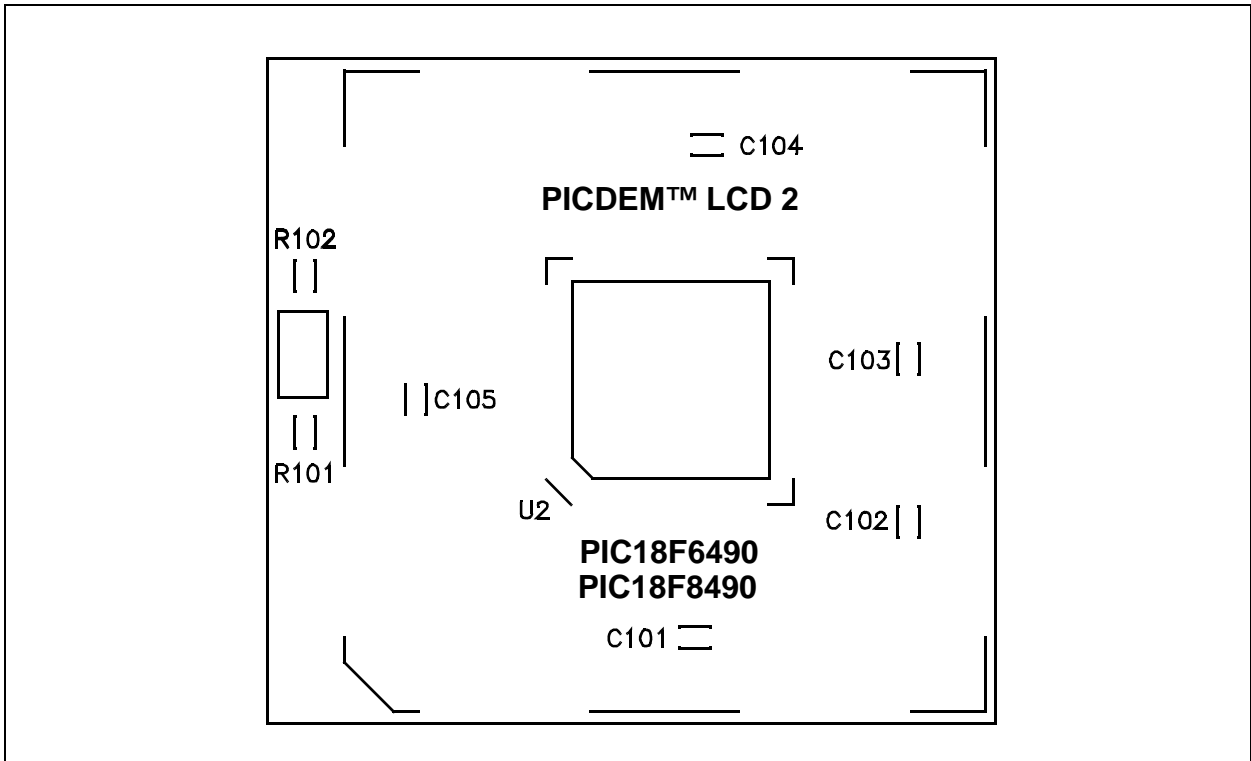

FIGURE A-18: PIC18F6490/8490 PIM LAYOUT



PICDEM™ LCD 2 Demonstration Kit User's Guide

FIGURE A-19: PIC18F87J90 PIM LAYOUT

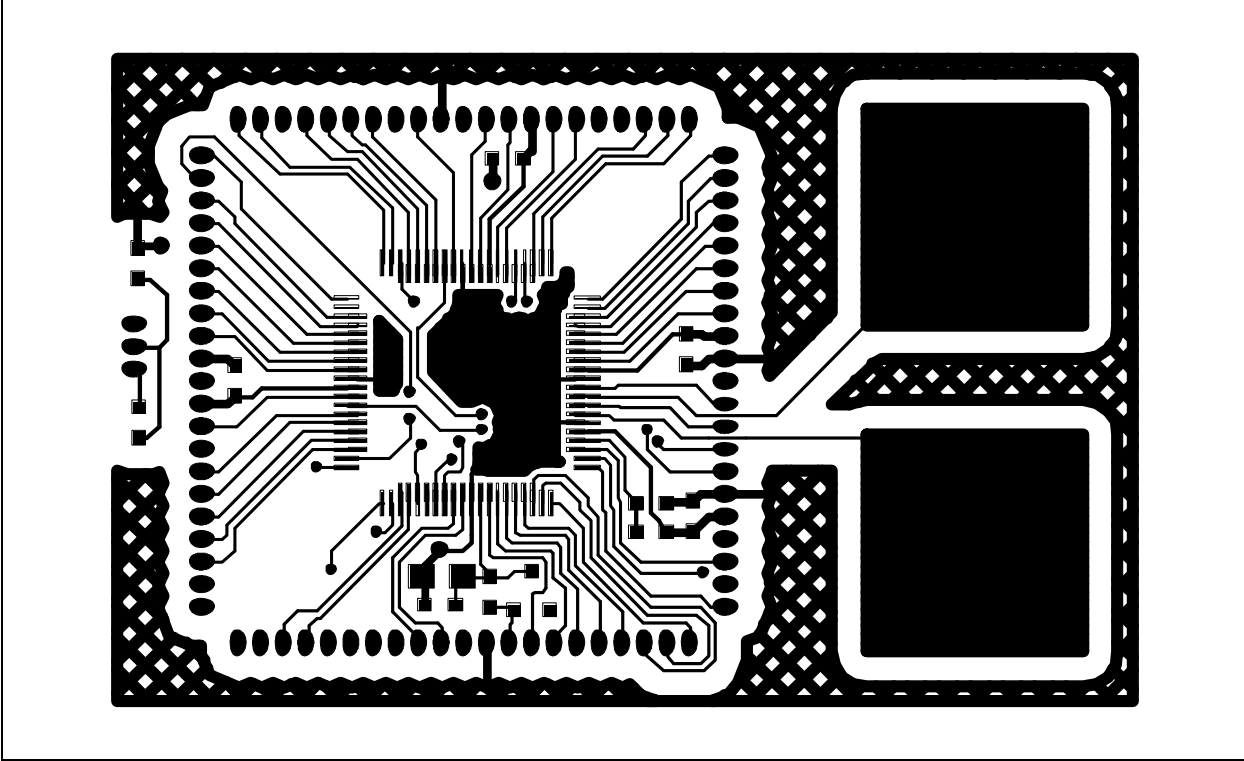

FIGURE A-20: PICDEM™ LCD 2 PIC16F914/917 PIM SCHEMATIC

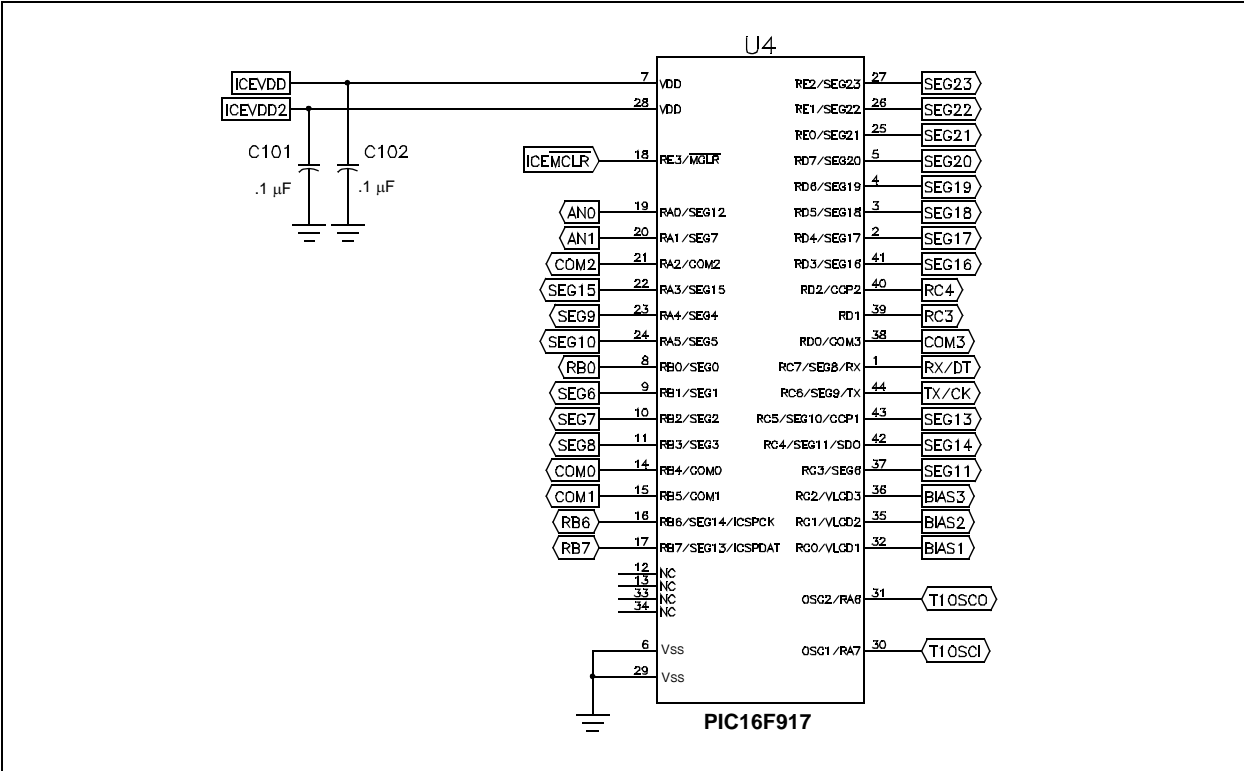

FIGURE A-21: PICDEM™ LCD 2 PIC16F946 PIM SCHEMATIC

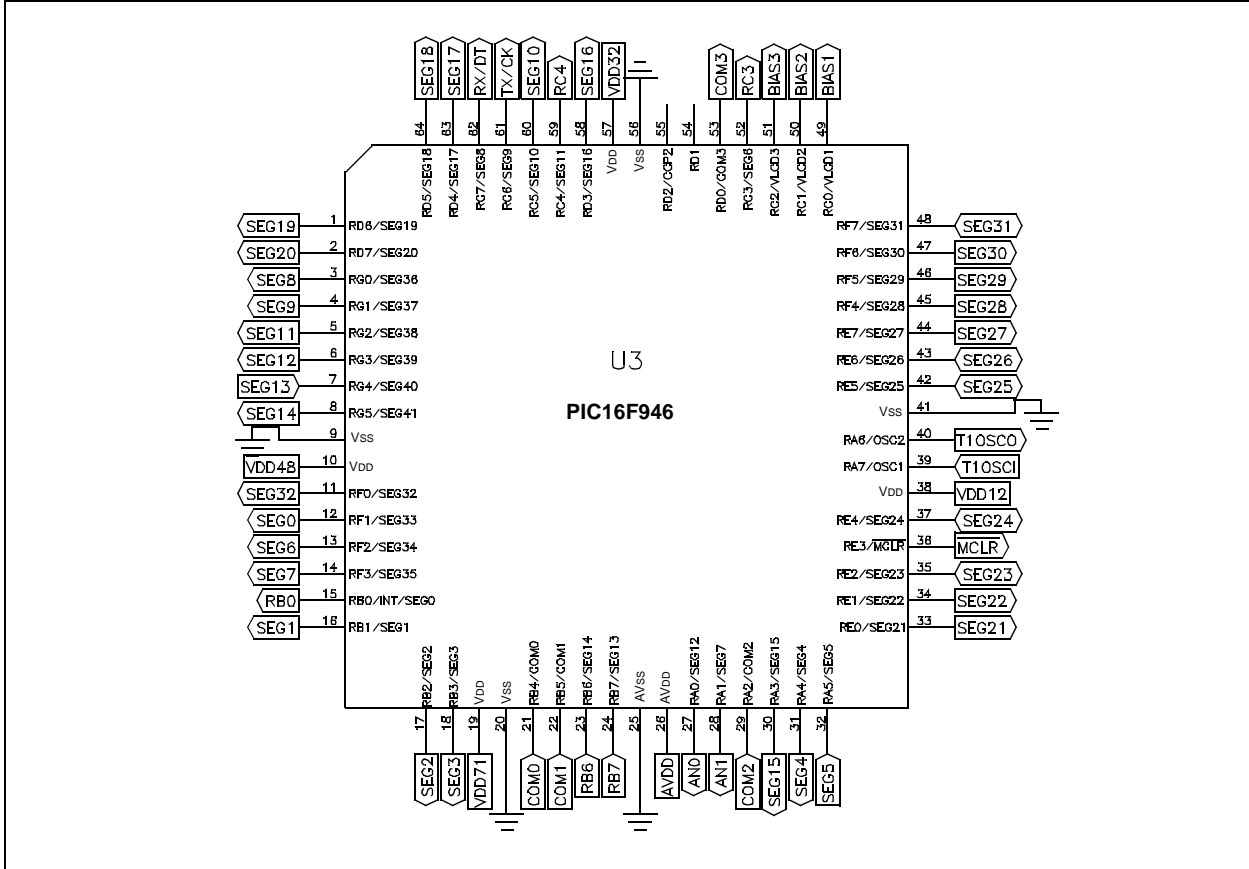
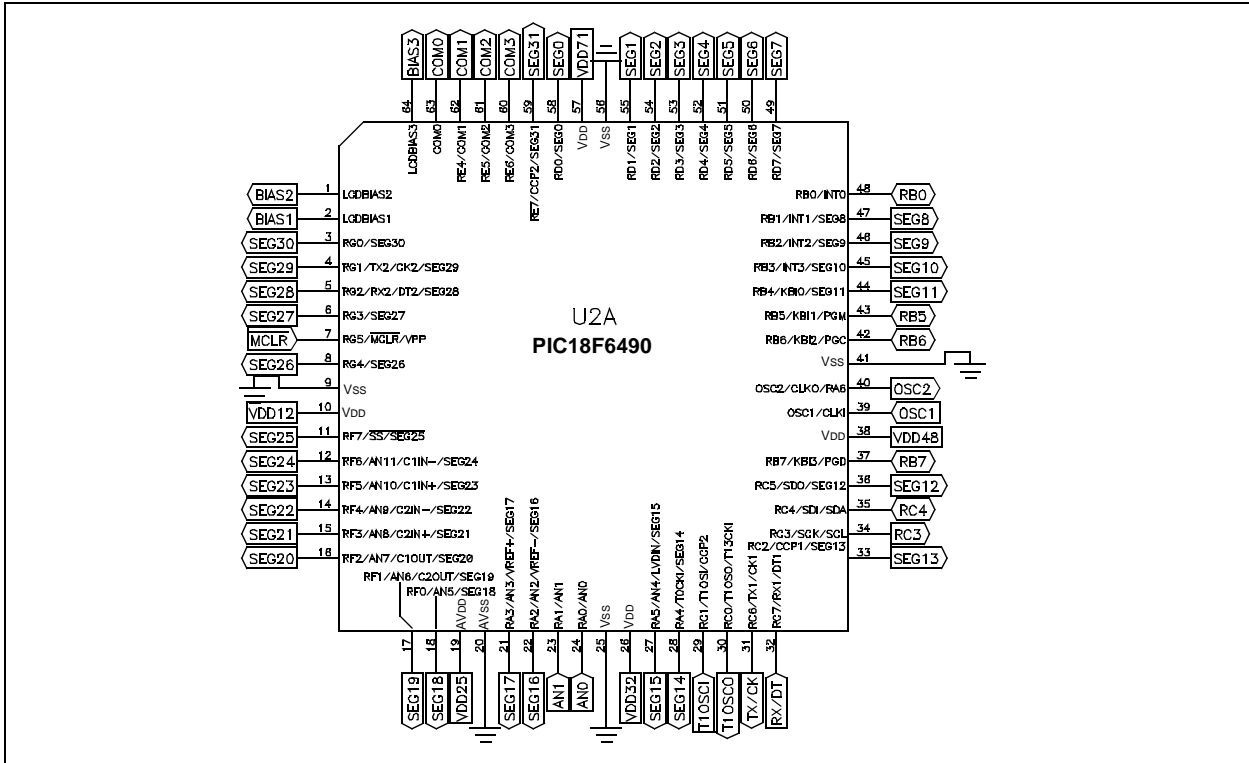

FIGURE A-22: PICDEM™ LCD 2 PIC18F6490 64-PIN PIM SCHEMATIC



PICDEM™ LCD 2 Demonstration Kit User's Guide

FIGURE A-23: PICDEM™ LCD 2 PIC18F8490 80-PIN PIM SCHEMATIC

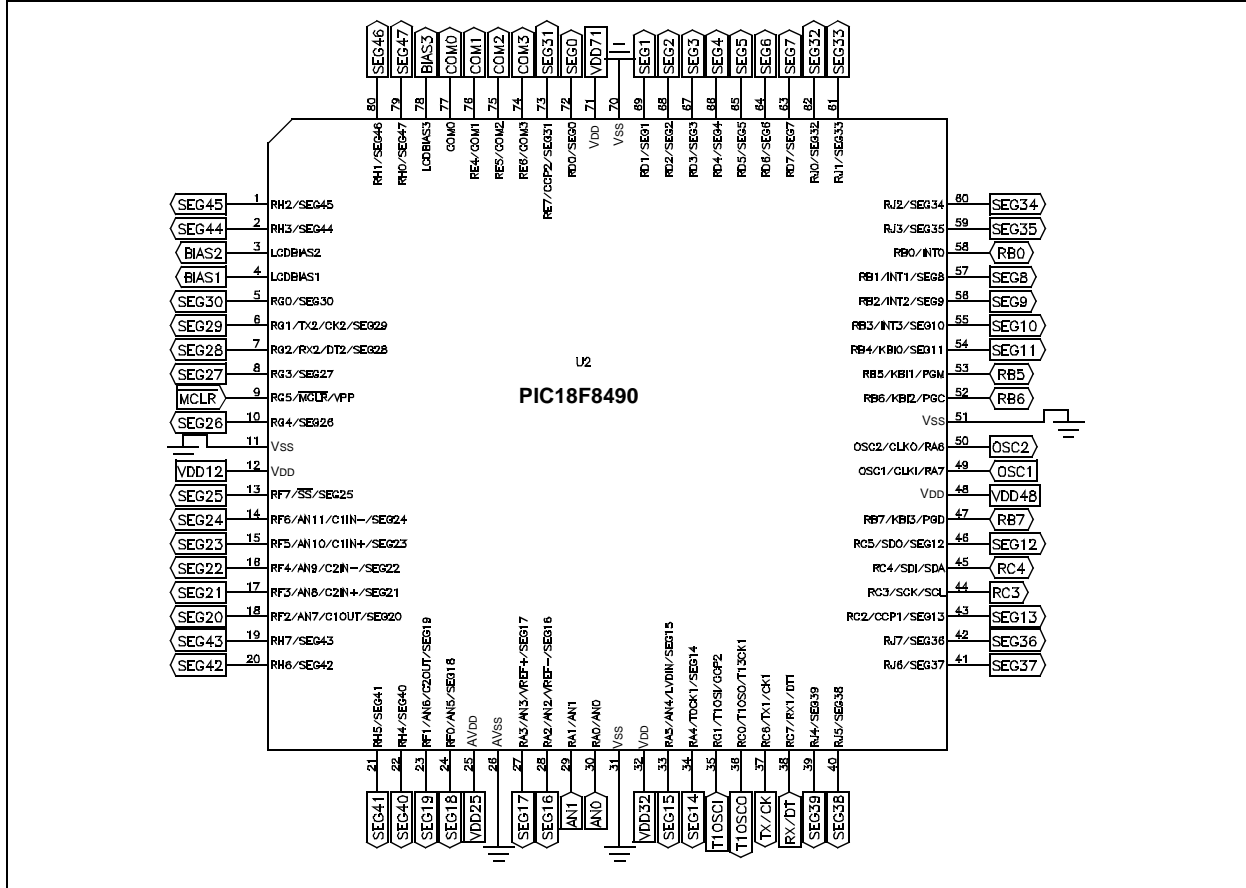

FIGURE A-24: PICDEM™ LCD 2 PIC18F6XJ90 64-PIN PIM SCHEMATIC

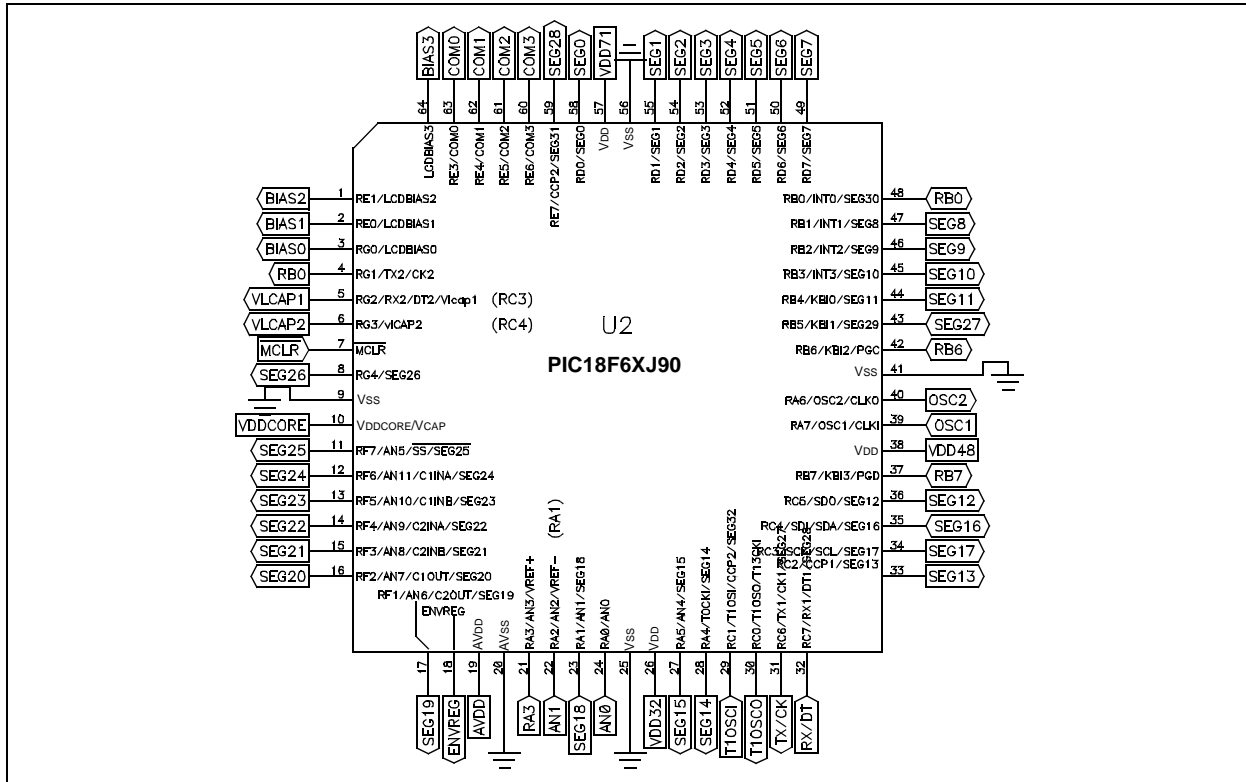
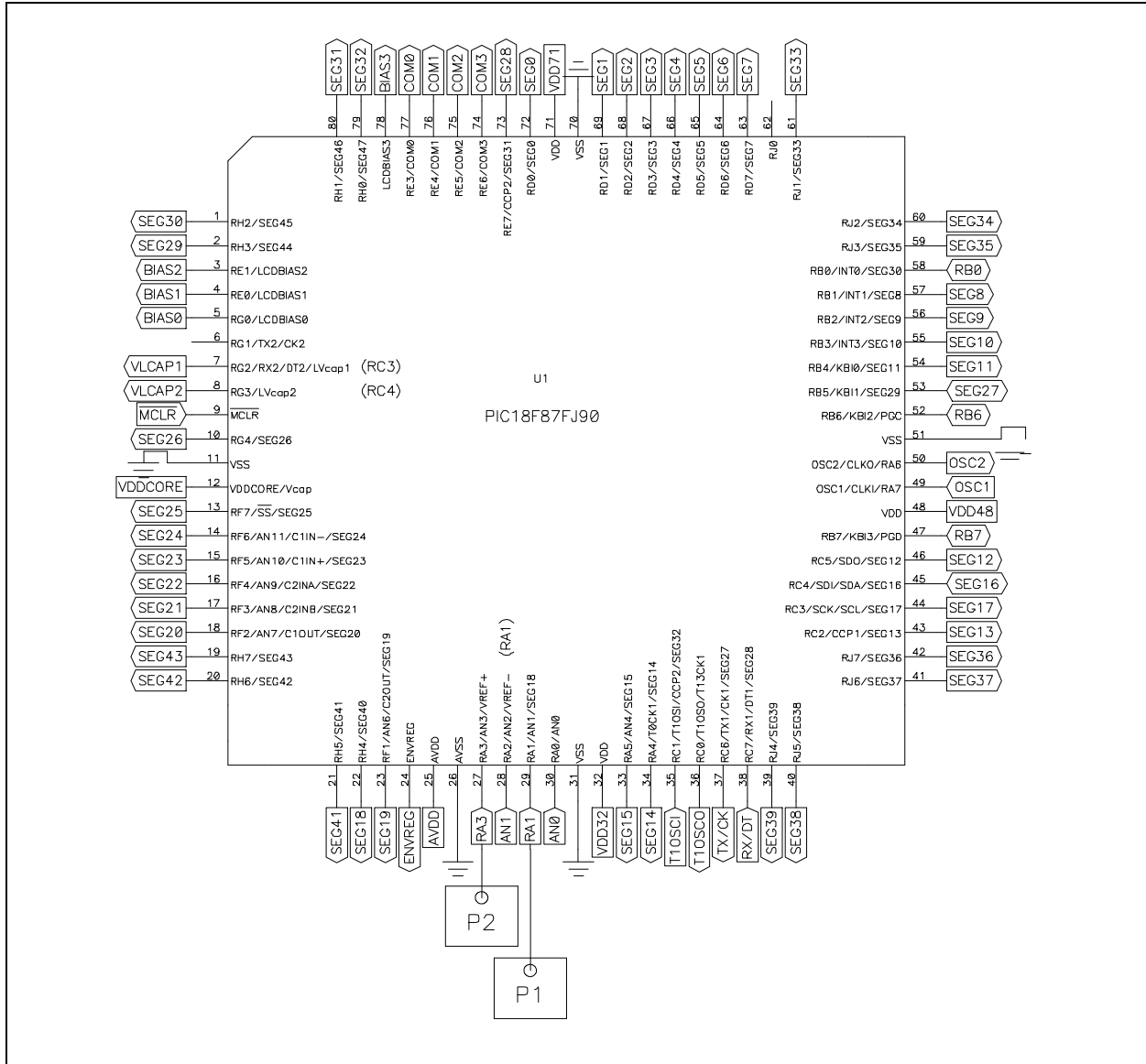
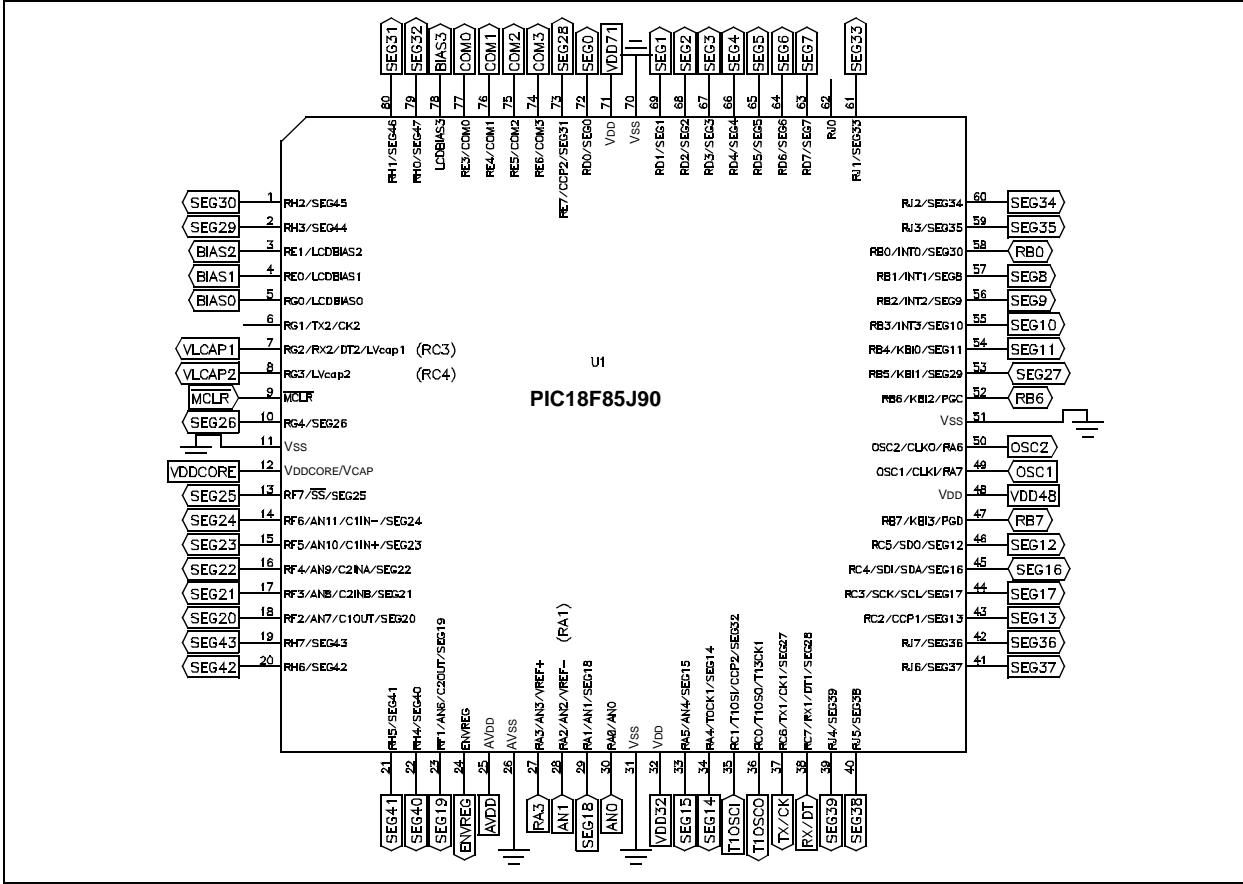

FIGURE A-25: PICDEM™ LCD 2 PIC18F87J90 80-PIN PIM SCHEMATIC



PICDEM™ LCD 2 Demonstration Kit User's Guide

FIGURE A-26: PICDEM™ LCD 2 PIC18F85J90 80-PIN PIM SCHEMATIC



NOTES:



PICDEM™ LCD 2 DEMONSTRATION KIT USER'S GUIDE

Index

A		P	
Analog Input.....	38	Part Numbers.....	19
B		PIC16XXXX	
Board.....	5	Demo.....	11
C		PIC18XXXX	
Charge Pump and Software Contrast.....	11	Demo Program.....	11
Clock.....	11	PICDEM LCD 2 Board	
Customer Support.....	4	Hardware.....	17
D		PICDEM LCD 2 Board. <i>See</i> Board.	
Demonstration Board. <i>See</i> Board.		PICDEM LCD 2 Demo Board.....	6
Demonstration Programs. <i>See</i> Sample Programs.		PICDEM LCD 2 Hardware (Graphic).....	7
Documentation		PICDEM LCD 2 Kit. <i>See</i> Kit Components.	
Conventions.....	2	PICDEM LCD 2 Stand-Alone Board.....	9
Layout.....	1	Power Supply.....	9
H		PICDEM LCD2 Board	
Hardware Features.....	6	Power Supply.....	40
I		Processors.....	19
Internet Address.....	3	Push Buttons. <i>See</i> Switches.	
K		R	
Kit Components.....	5	Reading, Recommended.....	3
L		Real-Time Clock.....	38
LCD		RS-232.....	6, 38
Digit Description.....	21	S	
Display Definition.....	21	Sample Devices.....	7
SEGx and COMx.....	22	Sample PIM.....	5
LCD Display.....	20	Sample Programs.....	5, 7
LEDs		Serial EEPROM.....	38
Green Display.....	37	Switches.....	6
Green Power.....	37	Analog Input.....	39
M		Digital I/O.....	39
Microchip Internet Web Site.....	3	T	
MPASM Assembler.....	9	Temperature Sensor.....	39
MPLAB C18 C Compiler.....	9	Thermometer.....	11
MPLAB ICD 2.....	5, 10, 39	U	
MPLAB ICE.....	5, 10	Using the Demo Software.....	11
MPLAB IDE.....	9	V	
O		Voltmeter.....	11
Oscillator Options.....	38	W	
Oscillator Selection.....	10	WWW Address.....	3



WORLDWIDE SALES AND SERVICE

AMERICAS

Corporate Office
2355 West Chandler Blvd.
Chandler, AZ 85224-6199
Tel: 480-792-7200
Fax: 480-792-7277
Technical Support:
<http://support.microchip.com>
Web Address:
www.microchip.com

Atlanta
Duluth, GA
Tel: 678-957-9614
Fax: 678-957-1455

Boston
Westborough, MA
Tel: 774-760-0087
Fax: 774-760-0088

Chicago
Itasca, IL
Tel: 630-285-0071
Fax: 630-285-0075

Dallas
Addison, TX
Tel: 972-818-7423
Fax: 972-818-2924

Detroit
Farmington Hills, MI
Tel: 248-538-2250
Fax: 248-538-2260

Kokomo
Kokomo, IN
Tel: 765-864-8360
Fax: 765-864-8387

Los Angeles
Mission Viejo, CA
Tel: 949-462-9523
Fax: 949-462-9608

Santa Clara
Santa Clara, CA
Tel: 408-961-6444
Fax: 408-961-6445

Toronto
Mississauga, Ontario,
Canada
Tel: 905-673-0699
Fax: 905-673-6509

ASIA/PACIFIC

Asia Pacific Office
Suites 3707-14, 37th Floor
Tower 6, The Gateway
Harbour City, Kowloon
Hong Kong
Tel: 852-2401-1200
Fax: 852-2401-3431

Australia - Sydney
Tel: 61-2-9868-6733
Fax: 61-2-9868-6755

China - Beijing
Tel: 86-10-8528-2100
Fax: 86-10-8528-2104

China - Chengdu
Tel: 86-28-8665-5511
Fax: 86-28-8665-7889

China - Hong Kong SAR
Tel: 852-2401-1200
Fax: 852-2401-3431

China - Nanjing
Tel: 86-25-8473-2460
Fax: 86-25-8473-2470

China - Qingdao
Tel: 86-532-8502-7355
Fax: 86-532-8502-7205

China - Shanghai
Tel: 86-21-5407-5533
Fax: 86-21-5407-5066

China - Shenyang
Tel: 86-24-2334-2829
Fax: 86-24-2334-2393

China - Shenzhen
Tel: 86-755-8203-2660
Fax: 86-755-8203-1760

China - Wuhan
Tel: 86-27-5980-5300
Fax: 86-27-5980-5118

China - Xiamen
Tel: 86-592-2388138
Fax: 86-592-2388130

China - Xian
Tel: 86-29-8833-7252
Fax: 86-29-8833-7256

China - Zhuhai
Tel: 86-756-3210040
Fax: 86-756-3210049

ASIA/PACIFIC

India - Bangalore
Tel: 91-80-4182-8400
Fax: 91-80-4182-8422

India - New Delhi
Tel: 91-11-4160-8631
Fax: 91-11-4160-8632

India - Pune
Tel: 91-20-2566-1512
Fax: 91-20-2566-1513

Japan - Yokohama
Tel: 81-45-471- 6166
Fax: 81-45-471-6122

Korea - Daegu
Tel: 82-53-744-4301
Fax: 82-53-744-4302

Korea - Seoul
Tel: 82-2-554-7200
Fax: 82-2-558-5932 or
82-2-558-5934

Malaysia - Kuala Lumpur
Tel: 60-3-6201-9857
Fax: 60-3-6201-9859

Malaysia - Penang
Tel: 60-4-227-8870
Fax: 60-4-227-4068

Philippines - Manila
Tel: 63-2-634-9065
Fax: 63-2-634-9069

Singapore
Tel: 65-6334-8870
Fax: 65-6334-8850

Taiwan - Hsin Chu
Tel: 886-3-572-9526
Fax: 886-3-572-6459

Taiwan - Kaohsiung
Tel: 886-7-536-4818
Fax: 886-7-536-4803

Taiwan - Taipei
Tel: 886-2-2500-6610
Fax: 886-2-2508-0102

Thailand - Bangkok
Tel: 66-2-694-1351
Fax: 66-2-694-1350

EUROPE

Austria - Wels
Tel: 43-7242-2244-39
Fax: 43-7242-2244-393

Denmark - Copenhagen
Tel: 45-4450-2828
Fax: 45-4485-2829

France - Paris
Tel: 33-1-69-53-63-20
Fax: 33-1-69-30-90-79

Germany - Munich
Tel: 49-89-627-144-0
Fax: 49-89-627-144-44

Italy - Milan
Tel: 39-0331-742611
Fax: 39-0331-466781

Netherlands - Drunen
Tel: 31-416-690399
Fax: 31-416-690340

Spain - Madrid
Tel: 34-91-708-08-90
Fax: 34-91-708-08-91

UK - Wokingham
Tel: 44-118-921-5869
Fax: 44-118-921-5820