



D SUBMINIATURE CONNECTOR J SERIES

Solder pot plug and socket

SOLDER POT PLUG AND SOCKET



Solder pot plug



Solder pot socket

Features

- The socket contacts are formed by high-speed stamping presses to obtain the advantages of cold working. They are therefore highly elastic, which in turn ensures reliable connection even after many mating cycles.
- The dimples in the plug shell ensure continuity between it and the socket shell, thus providing complete shielding.

- Costs are kept low by selective gold plating the contacts.
- The solder cup portions of the contacts are tin-plated for easy soldering.
- Insulator housings are made of a heat-resistant glass-filled PBT resin.

Standards

Recognized E60389 Certified LR20812

- * Compliant with RoHS.
- * Refer to "General Instruction and Notice when using Terminals and Connectors" at the end of this catalog.
- * Contact JST for details.

Specifications

Materials

Connector	Part name	Material and Finish
Plug	Contact	Brass, gold-plated product: Nickel-undercoated, Mating part: gold-plated Solder tail: tin-plated (reflow treatment) tin-plated product: Copper-undercoated, tin-plated (reflow treatment)
	Insulator	Glass-filled PBT, UL94V-0, black
	Shell	Steel, copper-undercoated, nickel-plated
Socket	Contact	Phosphor bronze, gold-plated product: Nickel-undercoated, Mating part: gold-plated Solder tail: tin-plated (reflow treatment) tin-plated product: Copper-undercoated, tin-plated (reflow treatment)
	Insulator	Glass-filled PBT, UL94V-0, black
	Shell	Steel, copper-undercoated, nickel-plated

Characteristics

Current rating	3A, AC, DC (2A for 37-circuits)
Voltage rating	250V AC, DC
Temperature range	-40°C to +85°C (including temperature rise in applying electrical current)
Contact resistance	Initial value/15mΩ max. After environmental testing/30mΩ max.
Insulation resistance	5,000MΩ min.
Withstanding voltage	1,000V AC/minute

Note: Contact JST for details.

Model number identification

	J	E	Z	-	9	P	-	12	-	3
• Series name	J E Z			-	9	P	-	12	-	3
• Shell size: E, A, B, C	E			-	9	P	-	12	-	3
• Wire connection style: Z ... Solder pot type	Z			-	9	P	-	12	-	3
• Number of circuits: 9, 15, 25, 37	9			-	9	P	-	12	-	3
• Connector style: P ... Plug, S ... Socket	P			-	9	P	-	12	-	3
• Finish Blank ... Gold-plated (flash) 12 ... 0.2micron gold-plated 13 ... 0.4micron gold-plated 14 ... 0.76micron gold-plated 90 ... Tin-plated (reflow treatment)	P			-	9	P	-	12	-	3
• Plating specification of shell: 3 ... Copper-undercoated, nickel-plated	P			-	9	P	-	12	-	3

Note: 1. The relationship between number of circuits and shell size is shown below.
9: E, 15: A, 25: B, 37: C
2. Contact JST for special plating requirements.

D SUBMINIATURE CONNECTOR J SERIES

Plug

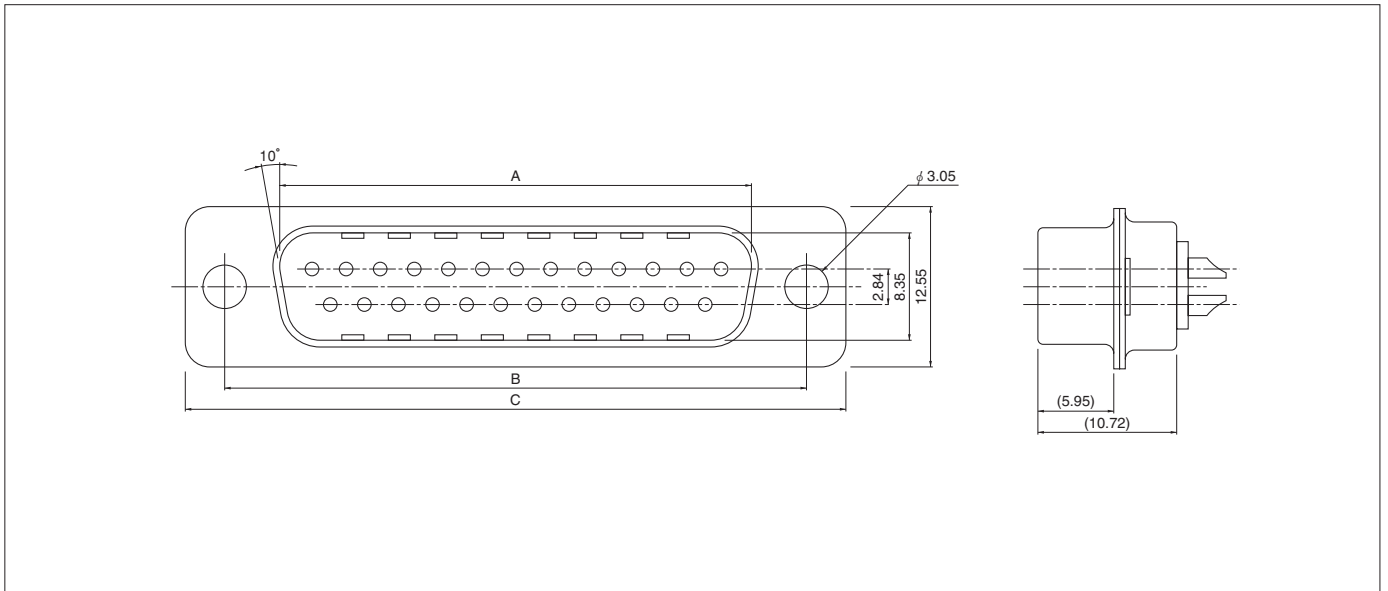

Circuits	Model No.		Dimensions (mm)			Q'ty / box
	Gold-plated	Tin-plated	A	B	C	
9	JEZ-9P-3	JEZ-9P-90-3	16.92	24.99	30.80	100
15	JAZ-15P-3	JAZ-15P-90-3	25.25	33.32	39.14	100
25	JBZ-25P-3	JBZ-25P-90-3	38.97	47.04	53.04	50
37	JCZ-37P-3	JCZ-37P-90-3	55.43	63.50	69.32	50

RoHS compliance Gold-plated products display (LF)(SN) on a label.

Socket

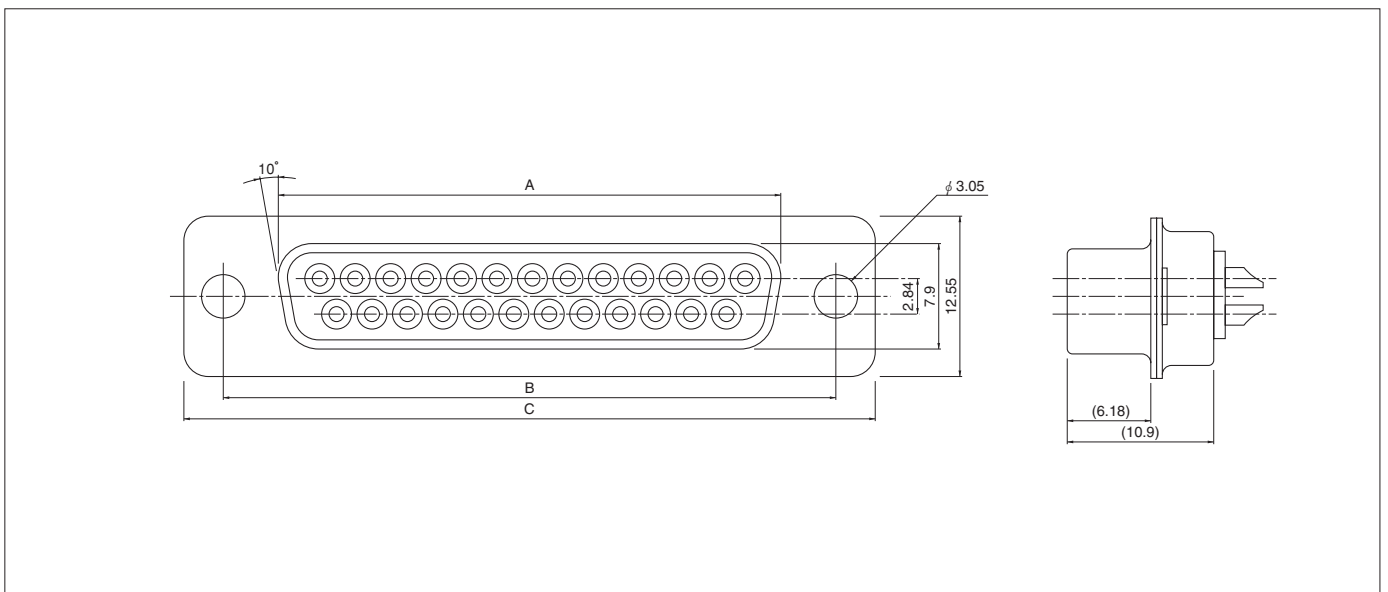

Circuits	Model No.		Dimensions (mm)			Q'ty / box
	Gold-plated	Tin-plated	A	B	C	
9	JEZ-9S-3	JEZ-9S-90-3	16.34	24.99	30.80	100
15	JAZ-15S-3	JAZ-15S-90-3	24.67	33.33	39.14	100
25	JBZ-25S-3	JBZ-25S-90-3	38.38	47.04	53.04	50
37	JCZ-37S-3	JCZ-37S-90-3	54.84	63.50	69.32	50

RoHS compliance Gold-plated products display (LF)(SN) on a label.



D SUBMINIATURE CONNECTOR J SERIES

Right angle through-hole plug and socket

RIGHT ANGLE THROUGH-HOLE PLUG AND SOCKET



Right angle through-hole plug
(with hexagonal lock screw blocks)



Right angle through-hole socket
(with rectangular lock screw blocks)

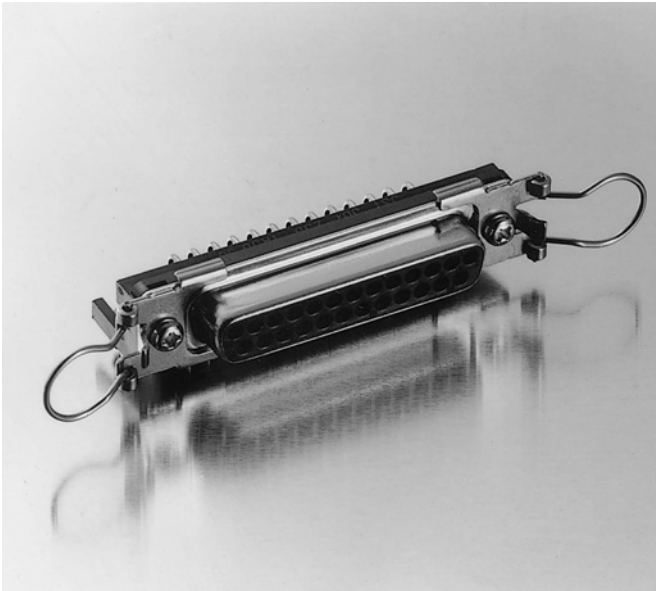

Right angle through-hole socket
(with bail lock)

Features

- The socket contacts are made by high-speed stamping presses. This promotes the uniform elasticity of the twin-contact mating sections and therefore ensures reliable contact even after repeated mating cycles. The solder tails are U-shaped for extra strength.
- Costs are minimized by selective gold plating, high speed stamping presses, and completely automated assembly.
- To ensure complete shielding, a wide variety of grounding adapters are available so that the sockets can be grounded to different kinds of supporting structures.
- Metric, inch or other lock screw blocks are available for fastening mating plugs.

D SUBMINIATURE CONNECTOR J SERIES

Specifications

Materials

Part name		Material and Finish
Contact	Plug	Brass, gold-plated product: Nickel-undercoated, Mating part: gold-plated Solder tail: tin-plated (reflow treatment) tin-plated product: Copper-undercoated, tin-plated (reflow treatment)
	Socket	Phosphor bronze, gold-plated product: Nickel-undercoated, Mating part: gold-plated Solder tail: tin-plated (reflow treatment) tin-plated product: Copper-undercoated, tin-plated (reflow treatment)
Insulator		Glass-filled PBT, UL94V-0, black
Shell		Steel, copper-undercoated, nickel-plated
Hexagonal lock screw block		Steel, copper-undercoated, nickel-plated
Rectangular lock screw block		Zinc, copper-undercoated, nickel-plated
Grounding adapter having a 3.2mm dia. hole		Steel, copper-undercoated, nickel-plated
Grounding adapter having an M3 tapped hole		
Grounding adapter having a spring lock lever		Brass, nickel-undercoated, tin/copper alloy-plated
Spring locks	Bail lock	Stainless steel
	Accepts bail locks	

Characteristics

Current rating	3A, AC, DC (2.0A AC, DC for 37-circuits)
Voltage rating	250V AC, DC
Temperature range	-40°C to +85°C (including temperature rise in applying electrical current)
Contact resistance	Initial value/15mΩ max. After environmental testing/30mΩ max.
Insulation resistance	5,000MΩ min.
Withstanding voltage	1,000V AC/minute
Applicable PC board thickness	1.6mm

Note: Contact JST for details.

Standards

Recognized E60389 Certified LR20812

* Compliant with RoHS.

* Refer to "General Instruction and Notice when using Terminals and Connectors" at the end of this catalog.

* Contact JST for details.







Model number identification

	J	E	Y	-	9	S	-	1A	3	A	12	S1
• Series name												
• Shell size: E, A, B, C												
• Wire connection style: Y... Right angle through-hole style												
• Number of circuits: 9, 15, 25, 37												
• Connector style: P ... Plug, S ... Socket												
• Connector construction/Dimensions: Standard J series												
• Types of grounding adapters 0 ... Without grounding adapters 1 ... With grounding adapters having a 3.2mm dia. hole 2 ... With grounding adapters having an M3 thread 3 ... With grounding adapters having a spring lock device (1) 4 ... With grounding adapters having a spring lock device (2)												
• Types of lock screw blocks A ... With hexagonal lock screw blocks having a No. 4-40 UNC inch thread B ... With hexagonal lock screw blocks having an M2.6 thread C ... With rectangular lock screw blocks having an M2.6 thread D ... Without lock screw blocks E ... Without lock screw blocks, but with grounding adapters having a 3.05mm dia. hole F ... Without lock screw blocks, but with grounding adapters having a No. 4-40UNC inch thread G ... Without lock screw blocks, but with grounding adapters having an M2.6 thread H ... Without lock screw blocks, but with grounding adapters having an M3 thread												
• Finish Blank ... Gold-plated (flash) 12 ... 0.2micron gold-plated 13 ... 0.4micron gold-plated 14 ... 0.76micron gold-plated 90 ... Tin-plated (reflow treatment)												
• Bail locks Blank...Without bail locks S or S1...With bail locks S2...With bail locks (with addition of spring characteristic)												
<p>Note: 1. The relationship between number of circuits and shell size is shown below. 9: E, 15: A, 25: B, 37: C 2. Contact JST for special plating requirements. 3. Contact JST for the Socket with bail locks. (Not UL/CSA approved.)</p>												

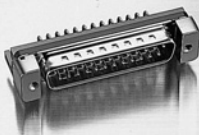
D SUBMINIATURE CONNECTOR J SERIES

Right angle through-hole plug		Type A	Type B																																											
<p>H: Height of the lock screw block (for Types A, B & C)</p> <table border="1"> <thead> <tr> <th rowspan="2">Cir- cuits</th> <th colspan="2">Model No.</th> <th colspan="5">Dimensions (mm)</th> <th rowspan="2">Q'ty / box</th> </tr> <tr> <th>gold-plated plug</th> <th>tin-plated plug</th> <th>A</th> <th>B</th> <th>C</th> <th>D</th> <th>E</th> </tr> </thead> <tbody> <tr> <td>9</td> <td>JEY-9P-1A**</td> <td>JEY-9P-1A**90</td> <td>16.90</td> <td>24.99</td> <td>30.80</td> <td>8.1</td> <td>9.52</td> <td>100</td> </tr> <tr> <td>15</td> <td>JAY-15P-1A**</td> <td>JAY-15P-1A**90</td> <td>25.25</td> <td>33.33</td> <td>39.14</td> <td>8.1</td> <td>9.52</td> <td>100</td> </tr> <tr> <td>25</td> <td>JBV-25P-1A**</td> <td>JBV-25P-1A**90</td> <td>38.97</td> <td>47.04</td> <td>53.00</td> <td>8.2</td> <td>9.62</td> <td>50</td> </tr> </tbody> </table> <p><Gold-plated product> RoHS compliance This product displays (LF)(SN) on a label. <Tin-plated product> *1, 2, 3 ... RoHS compliance *4, 5 ... RoHS compliance This product displays (LF) on a label. Note: ** shows the location where a two-digit code (see the table below for codes) should be entered. For example, if a 9-circuit gold-plated (flash) plug with hexagonal lock screw blocks having a No.4-40UNC inch thread and without grounding adapters is required, specify the model number as JEY-9P-1A0A.</p>		Cir- cuits	Model No.		Dimensions (mm)					Q'ty / box	gold-plated plug	tin-plated plug	A	B	C	D	E	9	JEY-9P-1A**	JEY-9P-1A**90	16.90	24.99	30.80	8.1	9.52	100	15	JAY-15P-1A**	JAY-15P-1A**90	25.25	33.33	39.14	8.1	9.52	100	25	JBV-25P-1A**	JBV-25P-1A**90	38.97	47.04	53.00	8.2	9.62	50	<p>With hexagonal lock screw blocks(H:6.3mm) having a No.4-40UNC inch thread</p>	<p>With hexagonal lock screw blocks(H:6.3mm) having an M2.6 thread</p>
Cir- cuits	Model No.		Dimensions (mm)					Q'ty / box																																						
	gold-plated plug	tin-plated plug	A	B	C	D	E																																							
9	JEY-9P-1A**	JEY-9P-1A**90	16.90	24.99	30.80	8.1	9.52	100																																						
15	JAY-15P-1A**	JAY-15P-1A**90	25.25	33.33	39.14	8.1	9.52	100																																						
25	JBV-25P-1A**	JBV-25P-1A**90	38.97	47.04	53.00	8.2	9.62	50																																						
<p>*1 Without grounding adapters</p>			0A	0B																																										
<p>*2 With grounding adapters with a 3.2mm dia. hole</p>			1A	1B																																										
<p>*3 With grounding adapters with an M3 thread</p>			2A	2B																																										
<p>*4 With grounding adapters with a spring lock device (1)</p>			3A	3B																																										
<p>*5 With grounding adapters with a spring lock device (2)</p>			—	—																																										



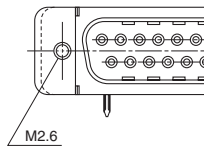
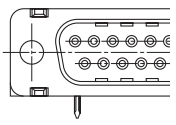
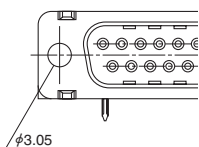
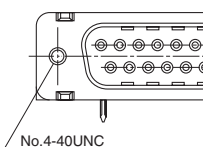
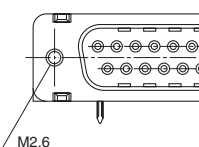
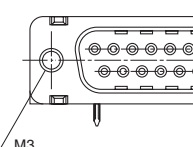



D SUBMINIATURE CONNECTOR J SERIES

Type C	Type D	Type E	Type F	Type G	Type H
					
With rectangular lock screw blocks (H: 6.2mm) having an M2.6 thread	Without lock screw blocks	Without lock screw blocks E: Grounding adapter has no thread. F, G, H: Grounding adapters have a thread (*1) for securing separately-purchased lock screw blocks (*2)			
		Use a lock screw block of Model number JFS-()S-C1N.	*1: No.4-40UNC inch thread *2: Model number JFS-4S-()1W(M)	*1: M2.6 thread *2: Model number JFS-2.6S-()1W(M)	*1: M3 thread *2: Model number JFS-3S-()1W(M)
					
0C	0D	—	—	—	—
1C	1D	1E	1F	1G	—
2C	2D	2E	2F	2G	—
3C	3D	3E	3F	3G	—
—	—	—	—	—	4H

D SUBMINIATURE CONNECTOR J SERIES

Right angle through-hole socket		Type A	Type B																																																				
<p>H: Height of the lock screw block (for Types A, B & C)</p> <table border="1"> <thead> <tr> <th rowspan="2">Cir- cuits</th> <th colspan="2">Model No.</th> <th colspan="5">Dimensions (mm)</th> <th rowspan="2">Q'ty / box</th> </tr> <tr> <th>gold-plated socket</th> <th>tin-plated socket</th> <th>A</th> <th>B</th> <th>C</th> <th>D</th> <th>E</th> </tr> </thead> <tbody> <tr> <td>9</td> <td>JEY-9S-1A**</td> <td>JEY-9S-1A**90</td> <td>16.34</td> <td>24.99</td> <td>30.81</td> <td>8.1</td> <td>9.52</td> <td>100</td> </tr> <tr> <td>15</td> <td>JAY-15S-1A**</td> <td>JAY-15S-1A**90</td> <td>24.67</td> <td>33.32</td> <td>39.14</td> <td>8.1</td> <td>9.52</td> <td>100</td> </tr> <tr> <td>25</td> <td>JBY-25S-1A**</td> <td>JBY-25S-1A**90</td> <td>38.38</td> <td>47.04</td> <td>53.04</td> <td>8.2</td> <td>9.62</td> <td>50</td> </tr> <tr> <td>37</td> <td>JCY-37S-1A**</td> <td>JCY-37S-1A**90</td> <td>54.84</td> <td>63.50</td> <td>69.32</td> <td>8.2</td> <td>9.62</td> <td>50</td> </tr> </tbody> </table> <p><Gold-plated product> RoHS compliance This product displays (LF)(SN) on a label. <Tin-plated product> *1, 2, 3 ... RoHS compliance *4, 5 ... RoHS compliance This product displays (LF) on a label.</p> <p>Note: ** shows the location where a two-digit code (see the table below for codes) should be entered. For example, if a 9-circuit gold-plated (flash) socket with hexagonal lock screw blocks having a No.4-40UNC inch thread and without grounding adapters is required, specify the model number as JEY-9S-1A0A.</p>		Cir- cuits	Model No.		Dimensions (mm)					Q'ty / box	gold-plated socket	tin-plated socket	A	B	C	D	E	9	JEY-9S-1A**	JEY-9S-1A**90	16.34	24.99	30.81	8.1	9.52	100	15	JAY-15S-1A**	JAY-15S-1A**90	24.67	33.32	39.14	8.1	9.52	100	25	JBY-25S-1A**	JBY-25S-1A**90	38.38	47.04	53.04	8.2	9.62	50	37	JCY-37S-1A**	JCY-37S-1A**90	54.84	63.50	69.32	8.2	9.62	50	<p>With hexagonal lock screw blocks(H: 6.3mm) having a No.4-40UNC inch thread</p>	<p>With hexagonal lock screw blocks(H: 6.3mm) having an M2.6 thread</p>
Cir- cuits	Model No.		Dimensions (mm)					Q'ty / box																																															
	gold-plated socket	tin-plated socket	A	B	C	D	E																																																
9	JEY-9S-1A**	JEY-9S-1A**90	16.34	24.99	30.81	8.1	9.52	100																																															
15	JAY-15S-1A**	JAY-15S-1A**90	24.67	33.32	39.14	8.1	9.52	100																																															
25	JBY-25S-1A**	JBY-25S-1A**90	38.38	47.04	53.04	8.2	9.62	50																																															
37	JCY-37S-1A**	JCY-37S-1A**90	54.84	63.50	69.32	8.2	9.62	50																																															
*1 Without grounding adapters																																																							
*2 With grounding adapters with a 3.2mm dia. hole																																																							
*3 With grounding adapters with an M3 thread																																																							
*4 With grounding adapters with a spring lock device (1)																																																							
*5 With grounding adapters with a spring lock device (2)																																																							

D SUBMINIATURE CONNECTOR J SERIES

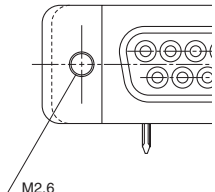
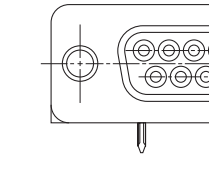
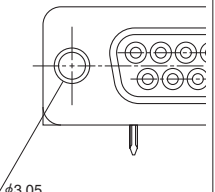
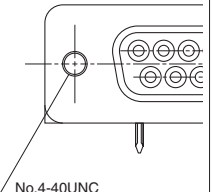
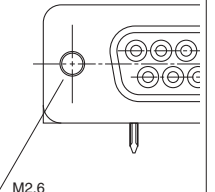
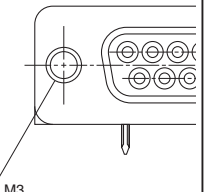
Type C	Type D	Type E	Type F	Type G	Type H
					
With rectangular lock screw blocks (H: 6.2mm) having an M2.6 thread	Without lock screw blocks	Without lock screw blocks E: Grounding adapter has no thread. F, G, H: Grounding adapters have a thread (*1) for securing separately-purchased lock screw blocks (*2)			
		Used a lock screw block [model number JFS-()S-C1N]	*1: No.4-40UNC inch thread *2: Model number JFS-4S-()1W(M)	*1: M2.6 thread *2: Model number JFS-2.6S-()1W(M)	*1: M3 thread *2: Model number JFS-3S-()1W(M)
					
0C	0D	—	—	—	—
1C	1D	1E	1F	1G	—
2C	2D	2E	2F	2G	—
3C	3D	3E	3F	3G	—
—	—	—	—	—	4H

D SUBMINIATURE CONNECTOR J SERIES

PC board layout (viewed from component side)

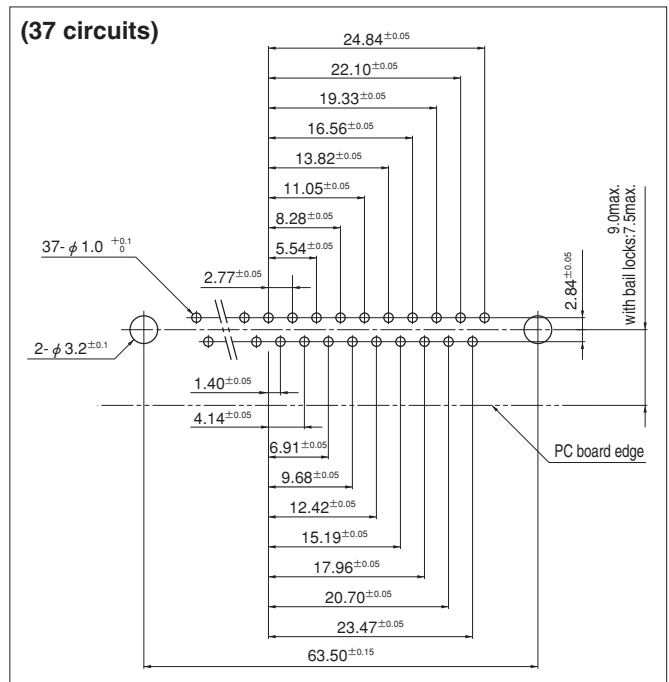
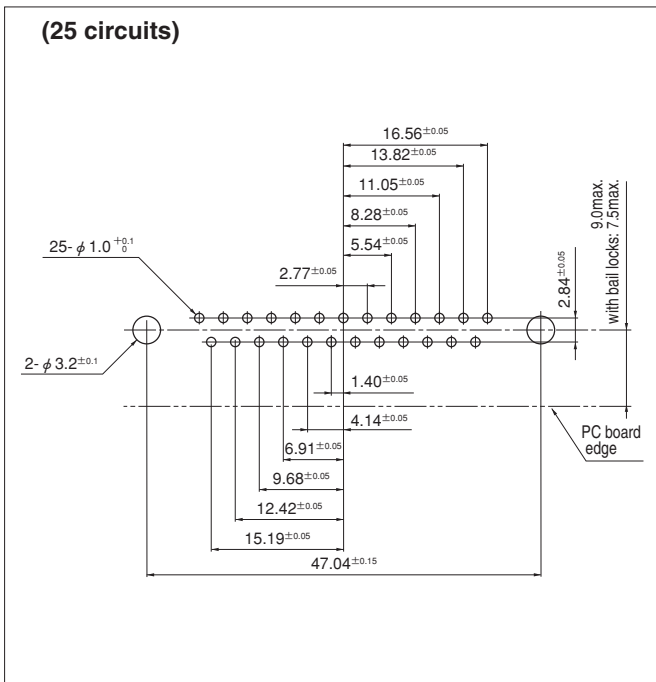
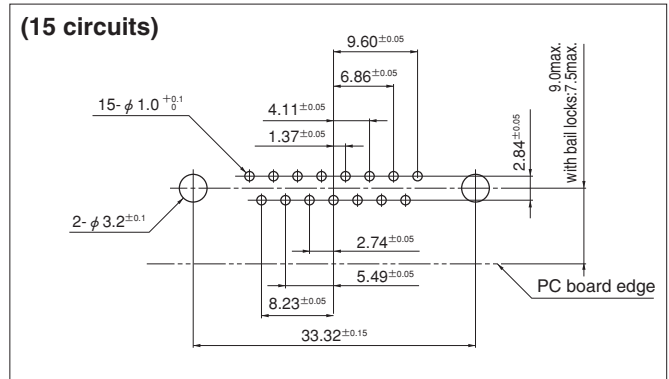
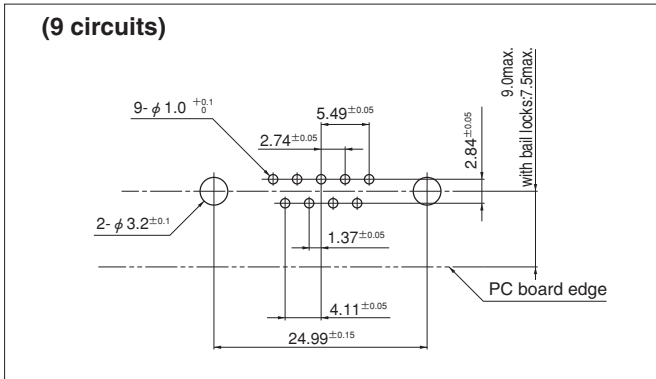

Note: 1. Tolerances are non-cumulative: $\pm 0.05\text{mm}$ for all centers.

2. Hole dimensions differ according to the kind of PC board and piercing method. The dimensions above should serve as a guideline. Contact JST for details.

Panel layout

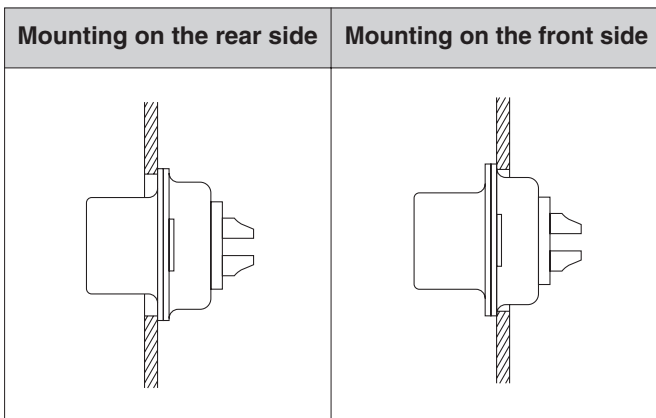

The connector can be mounted either on the front side or on the rear side of the panel as shown above.

Use M2.5 or M2.6 screws for installation.

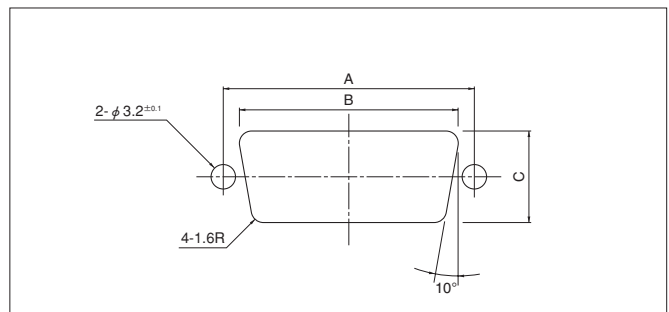

Circuits	A ± 0.15	B ± 0.2	C ± 0.2
9	24.99	20.6	12.0
15	33.32	28.8	12.0
25	47.04	42.6	12.0
37	63.50	59.0	12.0

Note: The dimensions above should serve as a guideline. Contact JST for details.

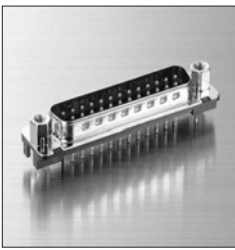

D SUBMINIATURE CONNECTOR J SERIES

Straight through-hole plug and socket

STRAIGHT THROUGH-HOLE PLUG AND SOCKET

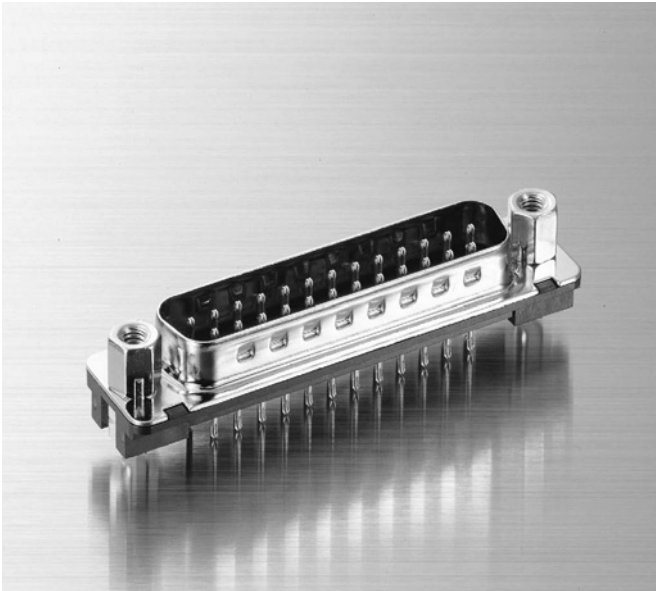

Straight through-hole plug
(with hexagonal lock screw blocks)

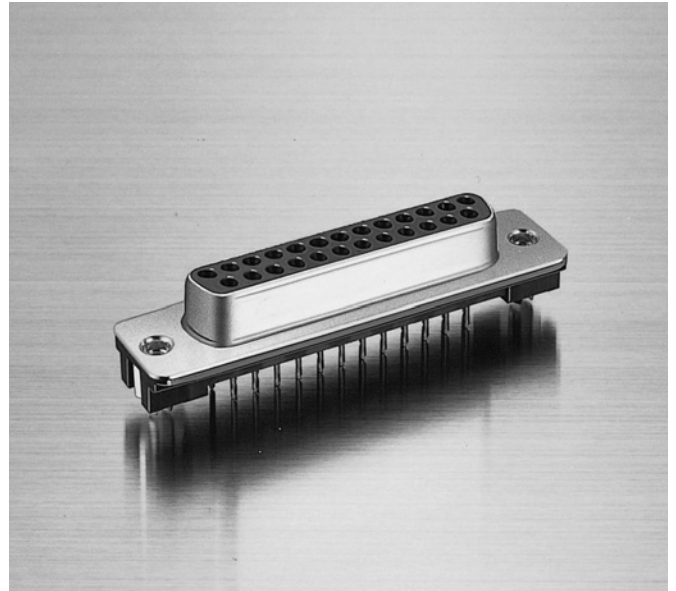

Straight through-hole socket (without lock screw blocks, but with
grounding adapters having a No.4-40UNC inch thread)

Features

- Three standard types are available with different dimensions between the flange and solder tail: 6mm, 9mm, and 12mm.
- The roots of the contact leads are covered to prevent flux from rising into the connector during soldering.
- A grounding adapter with a spring lock device allows the connector to be temporarily secured onto the printed circuit board so that the connector can be soldered easily.

Standards

 Recognized E60389

 Certified LR20812

- * Compliant with RoHS.
- * Refer to "General Instruction and Notice when using Terminals and Connectors" at the end of this catalog.
- * Contact JST for details.

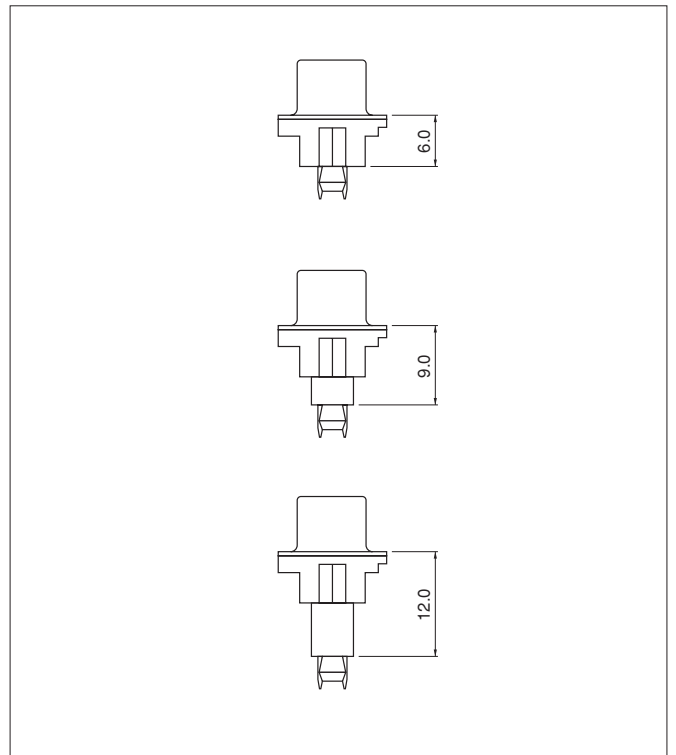

D SUBMINIATURE CONNECTOR J SERIES

Specifications

Materials

Part name		Material and Finish
Contact	Plug	Brass, gold-plated product: Nickel-undercoated, Mating part: gold-plated Solder tail; tin-plated (reflow treatment)
	Socket	Phosphor bronze, gold-plated product: Nickel-undercoated, Mating part: gold-plated Solder tail; tin-plated (reflow treatment)
Insulator		Glass-filled PBT, UL94V-0, black
Shell		Steel, copper-undercoated, nickel-plated
Hexagonal lock screw block		Steel, copper-undercoated, nickel-plated
Grounding adapter with spring lock device	Cutting product	Brass, nickel-undercoated, tin/copper alloy-plated
	Stamping product	Brass, tin-plated (reflow treatment)
Spring lock	Bail locks	Stainless steel
	Accepts bail locks	

Characteristics

Current rating	3A AC, DC
Voltage rating	250V AC, DC
Temperature range	-40°C to +85°C (including temperature rise in applying electrical current)
Contact resistance	Initial value/15mΩ max. After environmental testing/30mΩ max.
Insulation resistance	5,000MΩ min.
Withstanding voltage	1,000V AC/minute
Applicable PC board thickness	1.6mm

*Contact JST for details.

Straight through-hole plug

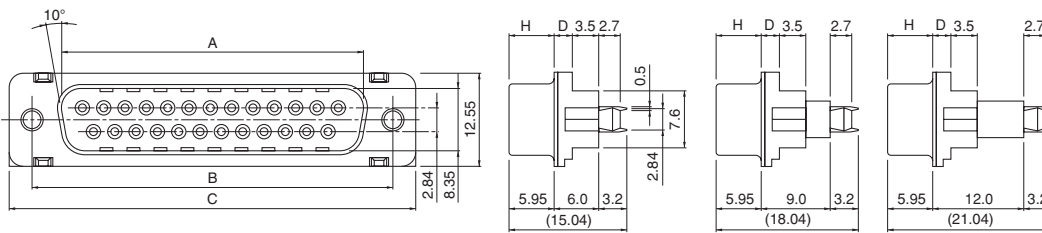

H: Height of the lock screw block (for Types A, B & J)

Cir- cuits	Dimension between flange and solder tail (mm)	Model No.		Dimensions (mm)				Q'ty / box
		Gold-plated (flash) Plug	Gold-plated 0.76micron	A	B	C	D	
9	6	JES-9P-2A**	JES-9P-2A**14	16.90	24.99	30.8	2.4	100
	9	JES-9P-3A**	JES-9P-3A**14					
	12	JES-9P-4A**	JES-9P-4A**14					
25	6	JBS-25P-2A**	JBS-25P-2A**14	38.97	47.04	53.0	2.5	50
	9	JBS-25P-3A**	JBS-25P-3A**14					
	12	JBS-25P-4A**	JBS-25P-4A**14					

RoHS compliance This product displays (LF)(SN) A on a label.

Note: ** shows the location where a two-digit code (see the table below for codes) should be entered. For example, if a 9-circuit gold-plated (flash) plug with hexagonal lock screw blocks having a No. 4-40UNC inch thread and with grounding adapters whose dimension between flange and solder tail is 6.0mm is required, specify the model number as JES-9P-3A3A.

Type A



With hexagonal lock screw blocks(H:6.3mm) having a No.4-40UNC inch thread

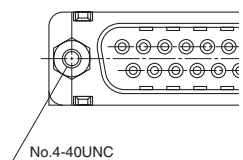

With grounding adapters with a spring lock device

6.0 mm type

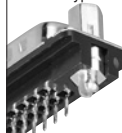

9.0 mm type

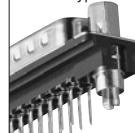

12.0 mm type

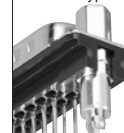

3A

D SUBMINIATURE CONNECTOR J SERIES

Model number identification

	J	B	S	-	25	P	-	2A	3	F	14	S1
• Series name												
• Shell size: B, E												
• Wire connection type: S ... Straight through-hole type												
• Number of circuits: 9, 25												
• Connector type: P ... Plug S ... Socket												
• Connector construction/dimensions: 2A ... 6.0 mm from flange to solder tail 3A ... 9.0 mm from flange to solder tail 4A ... 12.0mm from flange to solder tail												
• Types of grounding adapter: 3 ... Grounding adapter with a spring lock device (Cutting product), 7 ... Grounding adapter with a spring lock device (Stamping product)												
• Types of lock screw block: A ... With hexagonal lock screw blocks having a No. 4-40UNC inch thread B ... With hexagonal lock screw blocks having an M2.6 thread F ... Without lock screw blocks, but with grounding adapters having an No.4-40UNC inch thread G ... Without lock screw blocks, but with grounding adapters having an M2.6 thread H ... Without lock screw blocks, but with grounding adapters having an M3 thread J ... With hexagonal lock screw block having an M3 thread												
• Finish of mating part Blank ... Gold-plated (flash) 12 ... 0.2micron gold-plated 13 ... 0.4micron gold-plated 14 ... 0.76micron gold-plated 90 ... Tin-plated (reflow treatment)												
• Bail locks Blank...Without bail locks S or S1...With bail locks (bent oval type), S2...With bail locks (with addition of spring characteristic, bent oval type) S3...With bail locks (with addition of spring characteristic, Diamond type), S5...With bail locks (with addition of spring characteristic, straight oval type)												

*Note: 1. In the J Series, the number of circuits is determined by the shell size: 9 circuits for E and 25 circuits for B.
2. Contact JST for special plating requirements.
3. Contact JST for the dimensions between the flange and solder tail other than those listed above.
4. Grounding adapters that can secure printed circuit boards are also available.
5. Contact JST for the Receptacle with spring lock devices. (Not UL/CSA approved.)*

Type B	Type F	Type G	Type H	Type J
With hexagonal lock screw blocks (H: 6.3mm) having an M2.6 thread	Without lock screw blocks F, G, H: Grounding adapters have a thread (*1) for securing separately-purchased lock screw blocks (*2)		With hexagonal lock screw blocks (H: 6.3mm) having an M3 thread	
	*1: No.4-40UNC inch thread *2: Model number SFS-4S-()1W(M)	*1: M2.6 thread *2: Model number SFS-2.6S-()1W(M)	*1: M3 thread *2: Model number SFS-3S-()1W(M)	
3B	3F	3G	3H	3J

D SUBMINIATURE CONNECTOR J SERIES

Straight through-hole socket

Type A

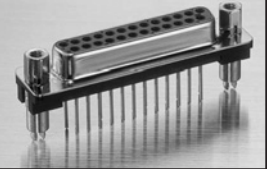
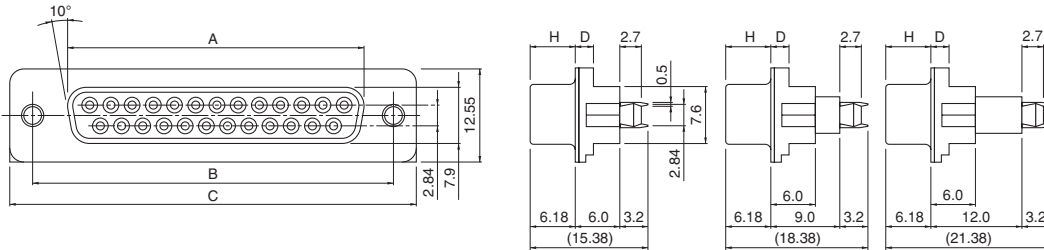

With hexagonal lock screw blocks(H:6.3mm) having a No.4-40UNC inch thread

H: Height of the lock screw block (for Types A, B & J)

Cir- cuits	Dimension between flange and solder tail (mm)	Model No.			Dimensions (mm)				Q'ty / box
		Gold-plated (flash) socket	Gold-plated 0.76micron	Tin-plated	A	B	C	D	
9	6	JES-9S-2A**	JES-9S-2A**14	—	16.34	24.99	30.8	2.4	100
	9	JES-9S-3A**	JES-9S-3A**14	—					
	12	JES-9S-4A**	JES-9S-4A**14	—					
25	6	JBS-25S-2A**	JBS-25S-2A**14	JBS-25S-2A**90	38.38	47.04	53.0	2.5	50
	9	JBS-25S-3A**	JBS-25S-3A**14	JBS-25S-3A**90					
	12	JBS-25S-4A**	JBS-25S-4A**14	—					

<Gold-plated product> **RoHS compliance** This product displays (LF)(SN) A on a label.

<Tin-plated product> **RoHS compliance** This product displays (LF) A on a label.

Note: ** shows the location where a two-digit code (see the table below for codes) should be entered. For example, if a 9-circuit gold-plated (flash) socket with hexagonal lock screw blocks having a No. 4-40UNC inch thread and with grounding adapters whose dimension between flange and solder tail is 6.0mm is required, specify the model number as JES-9S-3A3A.

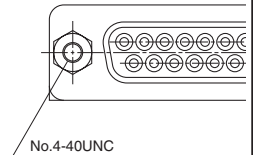

With grounding adapters
with a spring lock device

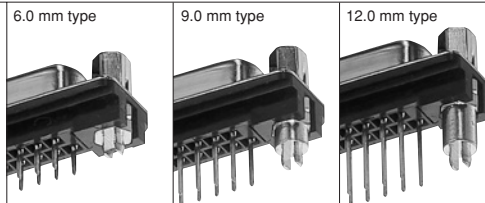

3A

PC board layout (viewed from component side)

(9-circuits)



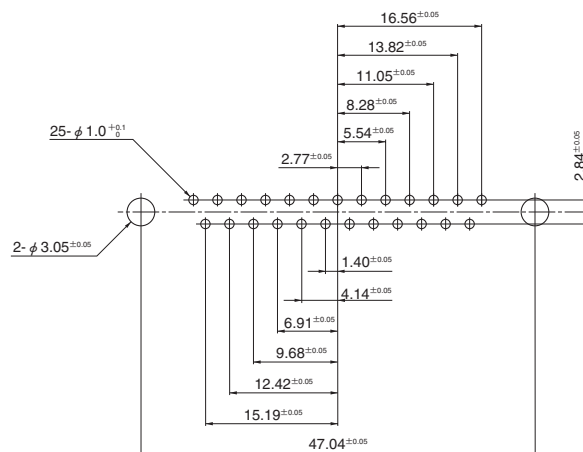
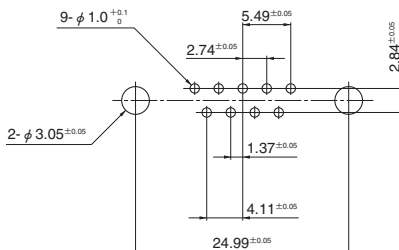

(25-circuits)



Note: 1. Tolerances are non-cumulative: $\pm 0.05\text{mm}$ for all centers.

2. Hole dimensions differ according to the kind of PC board and piercing method. The dimensions above should serve as a guideline. Contact JST for details.

D SUBMINIATURE CONNECTOR J SERIES

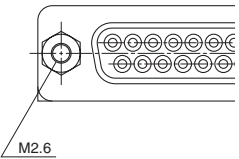
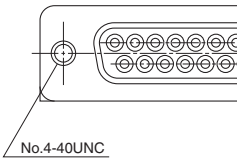
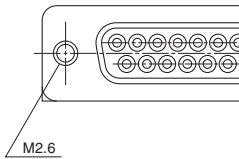
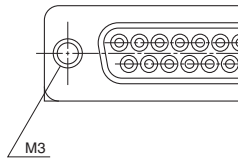
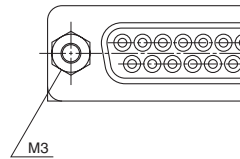
Type B	Type F	Type G	Type H	Type J
				
With hexagonal lock screw blocks (H: 6.3mm) having an M2.6 thread	Without lock screw blocks F, G, H: Grounding adapters have a thread (*1) for securing separately-purchased lock screw blocks (*2)			With hexagonal lock screw blocks (H: 6.3mm) having an M3 thread
	*1: No.4-40UNC inch thread *2: Model number SFS-4S-()1W(M)	*1: M2.6 thread *2: Model number SFS-2.6S-()1W(M)	*1: M3 thread *2: Model number SFS-3S-()1W(M)	
				
3B	3F	3G	3H	3J

Panel layout

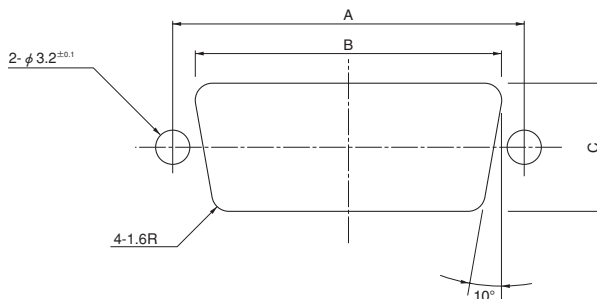

Circuits	A ± 0.15	B ± 0.2	C ± 0.2
9	24.99	20.6	12.0
25	47.04	42.6	12.0

Note: The dimensions above should serve as a guideline. Contact JST for details.



D SUBMINIATURE CONNECTOR J SERIES

Crimp style plug and socket

CRIMP STYLE PLUG AND SOCKET



Features

- The contacts of this plug are formed by high-speed stamping presses into continuous strips that can be automatically fed into our compact crimping machines. Much less time is required to assemble CRT and RS-232C round cables using this plug than when soldering connections.
- The contacts in this connector are selectively gold-plated. Moreover, JST's advanced technological knowledge and

experience are fully utilized to significantly reduce production costs.

- The dimples in the connector shell provide the ground connection and are important factors in preventing electromagnetic interference. The contact has a lance that can be visually checked during assembly. This assures accurate assembly and reduces defects.

Specifications

Materials

Connector	Part name	Material and Finish
Plug	Contact	Brass, gold-plated product: Nickel-undercoated, Mating part: gold-plated Crimping part: tin-plated (reflow treatment) tin-plated product: tin-plated (reflow treatment)
	Insulator	Glass-filled PBT, UL94V-0, black
	Shell	Steel, copper-undercoated, nickel-plated
Socket	Contact	Phosphor bronze, nickel-undercoated, Mating part: gold-plated Crimping part: tin-plated (reflow treatment)
	Insulator	Glass-filled PBT, UL94-0, black
	Shell	Steel, copper-undercoated, nickel-plated

Characteristics

Current rating	3A, AC, DC (2A for 37-circuits)(AWG #20)
Voltage rating	250V AC, DC
Temperature range	-40°C to +85°C (including temperature rise in applying electrical current)
Contact resistance	Initial value/15mΩ max. After environmental testing/30mΩ max.
Insulation resistance	5,000MΩ min.
Withstanding voltage	1,000V AC/minute

Note: Contact JST for details.

Model number identification

Contact

- Series name: **J - S P 2 1 40**
- Product shape: S ... Chain, B ... Loose piece
 - Type of contact: P ... Pin contact, S ... Socket contact
 - Applicable wire: 1 ... AWG #24 to #20, 2 ... AWG #28 to #24
 - Material: 1 ... Brass(Pin contact), 3 ... Phosphor bronze(Socket contact)
 - Finish: 40 ... Gold-plated (flash), 42 ... 0.2micron gold-plated
43 ... 0.4micron gold-plated, 44 ... 0.76micron gold-plated, 90 ... Tin-plated (reflow treatment)

Note: Contact JST for special plating requirements.

Housing

- Series name: **J E C - 9 P - 3**
- Shell size: E, A, B, C
 - Wire connection style: C ... crimp style
 - Number of circuits: 9, 15, 25, 37
 - Connector style: P ... Plug, S ... Socket
 - Plating specification of shell: 3 ... nickel-plated

Note: The relationship between number of circuits and shell size is shown below.
9: E, 15: A, 25: B, 37: C

Standards

Recognized E60389

Certified LR20812

* Compliant with RoHS.

* Refer to "General Instruction and Notice when using Terminals and Connectors" at the end of this catalog.

* Contact JST for details.

D SUBMINIATURE CONNECTOR J SERIES

Pin contact (for plug housing)

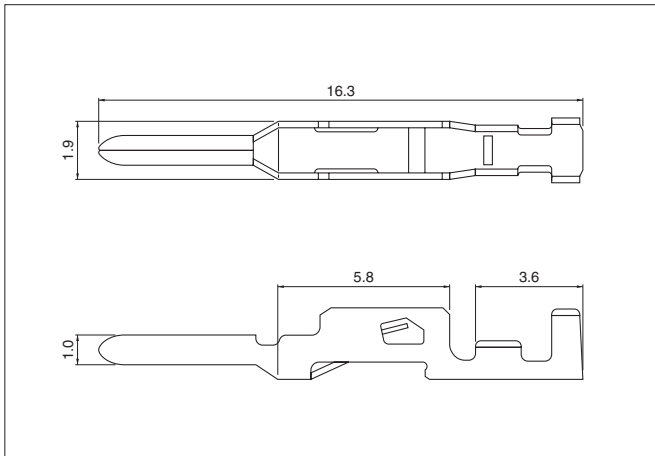

Socket contact (for socket housing)

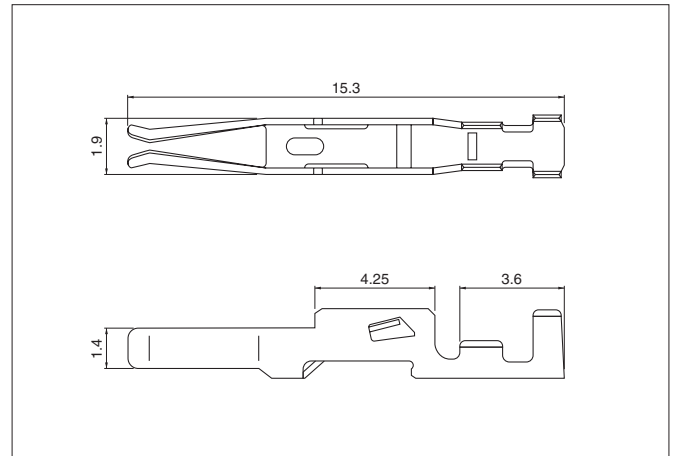

Model No.			Applicable wire		Q'ty / reel
Pin contact		Socket contact	AWG #	Insulation O.D. (mm)	
Gold-plated	Tin-plated	Gold-plated			
J-SP1140	J-SP1190	J-SS1340	# 24~# 20	1.1~1.8	
J-SP2140	J-SP2190	J-SS2340	# 28~# 24	0.9~1.3	

RoHS compliance Gold-plated products display (LF)(SN) on a label.

Plug housing

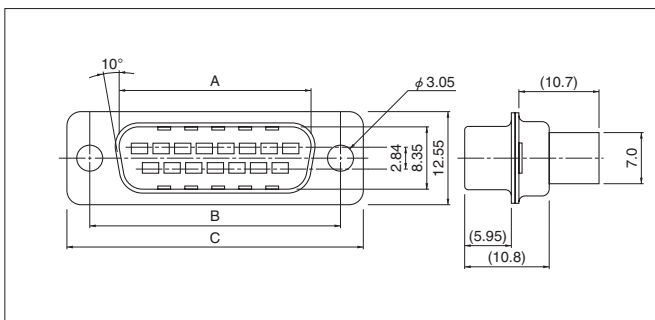

Cir- cuits	Model No.	Dimensions (mm)			Q'ty / box
		A	B	C	
9	JEC-9P-3	16.92	24.99	30.80	100
15	JAC-15P-3	25.25	33.32	39.14	100
25	JBC-25P-3	38.97	47.04	53.04	50
37	JCC-37P-3	55.43	63.50	69.32	50

RoHS compliance

Socket housing

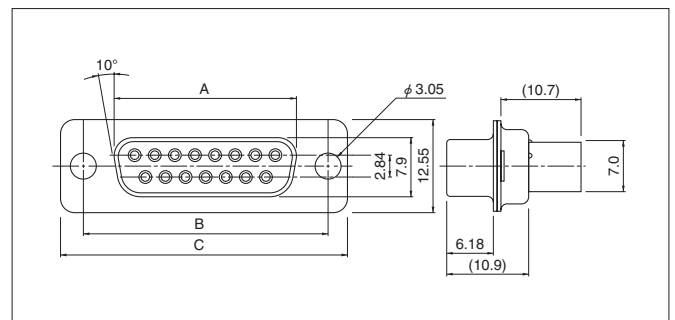

Cir- cuits	Model No.	Dimensions (mm)			Q'ty / box
		A	B	C	
9	JEC-9S-3	16.34	24.99	30.80	100
15	JAC-15S-3	24.67	33.33	39.14	100
25	JBC-25S-3	38.38	47.04	53.04	50

RoHS compliance

Crimping machine, Applicator

Contact	Crimping machine	Applicator		
		Crimp applicator	Dies	Crimp applicator with dies
J-SP1***	AP-K2N	MKS-L	MK/J-SP/SS1	APLMK J-SP/SS1
		*MKS-SC	SC/J-SP/SS1	APLSC J-SP/SS1
J-SS1***		MKS-L	MK/J-SP/SS1	APLMK J-SP/SS1
		*MKS-SC	SC/J-SP/SS1	APLSC J-SP/SS1
J-SP2***		MKS-L	MK/J-SP/SS2	APLMK J-SP/SS2
		*MKS-SC	SC/J-SP/SS2	APLSC J-SP/SS2
J-SS2***		MKS-L	MK/J-SP/SS2	APLMK J-SP/SS2
		*MKS-SC	SC/J-SP/SS2	APLSC J-SP/SS2

Note: *Strip-crimp applicator



D SUBMINIATURE J&JK SERIES

Accessories/EMI prevention shielding cover (J cover)

J COVER



J cover



Features

- This shielding cover is made of steel, formed by our advanced stamping technology, and nickel-plated.
- The box-shaped cover completely encloses such EMI radiating areas as the connections between the connector and wires. The result is a superior shielding effect.
- To install the shielding cover, simply align and press the upper and lower cover elements, then tighten the nuts. It then securely grips the round cables.
- This cover is so compact, light and sturdy, that it can be used to cover the connectors of any input/output cable. Moreover, it is attractive in appearance.
- * Compliant with RoHS.
- * Refer to "General Instruction and Notice when using Terminals and Connectors" at the end of this catalog.
- * Contact JST for details.

Standards

Recognized E60389

Applicable cable dimensions

Circuits	J series	9	15	25	37
	JK series	15	—	—	—
Cable outer diameter (mm)		7.0 ±0.2		8.0 ±0.2	10.0 ±0.2

Shielding cover A

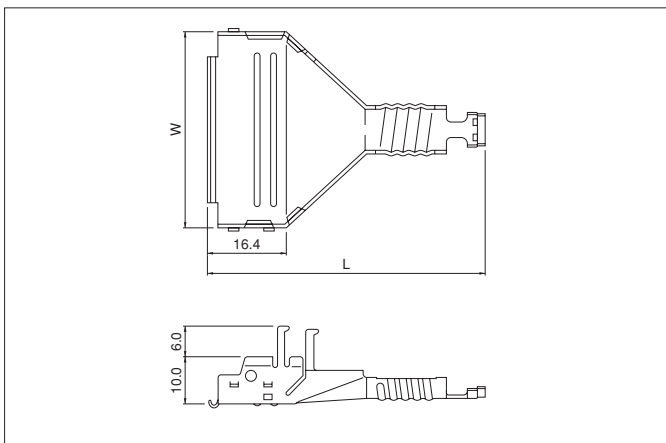

Shielding cover B

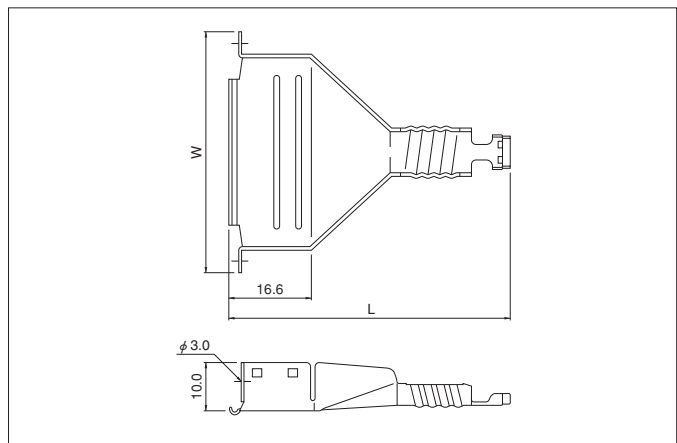

J series		JK series		Dimensions (mm)		Qty / box
Circuits	Model No.	Circuits	Model No.	W	L	
9	J-SC9A	15	JK-SC15A	19.4	42.0	200
15	J-SC15A	—	—	27.6	46.9	150
25	J-SC25A	—	—	41.4	57.0	100
37	J-SC37A	—	—	57.8	70.6	125

Material and Finish

Steel, copper- undercoated, nickel-plated

Circuits		Model No.	Dimensions (mm)		Qty / box
J series	JK series		W	L	
9	15	J-SC9B	30.0	(42.0)	200
15	—	J-SC15B	38.0	(46.9)	150
25	—	J-SC25B	52.0	(57.0)	150
37	—	J-SC37B	68.0	(70.6)	100

Material and Finish

Steel, copper- undercoated, nickel-plated

RoHS compliance

Note: The cover of the JK series 15-circuit connector is the same as that of the J series 9-circuit connector.

RoHS compliance

Note: The cover of the JK series 15-circuit connector is the same as that of the J series 9-circuit connector, except for the number of circuits indicated.

D SUBMINIATURE CONNECTOR J&JK SERIES

Cover nut

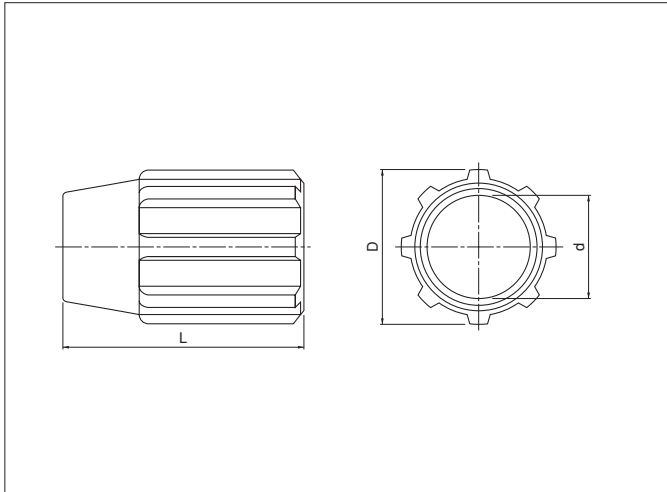

Circuits	Model No.	D	d	L	Q'ty / box
9	J-CN9 · 15	13.6	7.2	19.0	1,000
15					
25	J-CN25	16.4	8.4	25.0	1,000
37	J-CN37	18.8	10.4	28.0	1,500

Material

Glass-filled, PBT, UL94V-0, black

RoHS compliance

E-ring

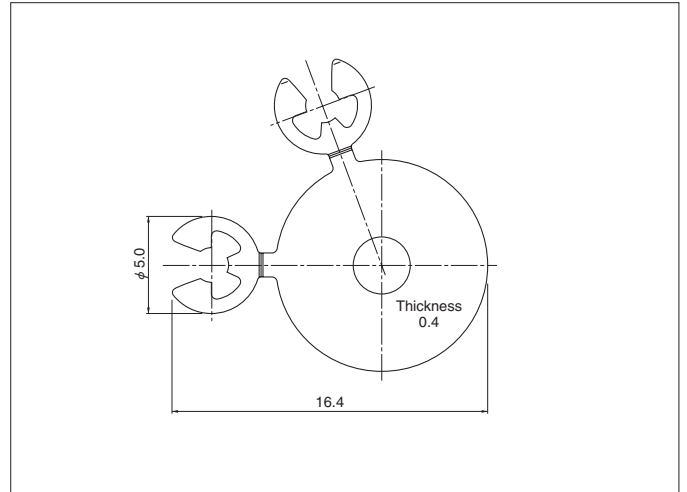

Model No.	Q'ty / box
J-ER	5,000
Material	
Stainless steel	

RoHS compliance

Note: The cover nuts, lock screws and E-rings are used with both the J and JK series connectors.

Lock screw

No.4-40UNC (Inch thread)	M2.6 (Metric thread)	M3 (Metric thread)

Type of screw	Model No.	Q'ty / box
No.4-40UNC (Inch thread)	J-SL-1C	5,000
M2.6 (Metric thread)	J-SL-2C	5,000
M3 (Metric thread)	J-SL-3C	5,000

Material and Finish

Steel, copper-undercoated, nickel-plated

RoHS compliance

Use the following Model Nos. when ordering J-covers as a set.

J series		JK series		Parts in one set	Q'ty / box
Circuits	Model No.	Circuits	Model No.		
9	J-C9-()C	15	JK-C15-()C	Shielding cover A 1 pc.	25
15	J-C15-()C	—	—	Shielding cover B 1 pc.	25
25	J-C25-()C	—	—	Cover nut 1 pc.	20
37	J-C37-()C	—	—	Lock screw 2 pcs.	10
				E-ring 1 set	

RoHS compliance

Note: In the above lock screw model numbers, the number in parentheses indicates the type of screw-1: Inch thread (No.4-40UNC), 2: Metric thread (M2.6), 3: Metric thread (M3).

D SUBMINIATURE CONNECTOR J&K SERIES

J-cover assembly procedure

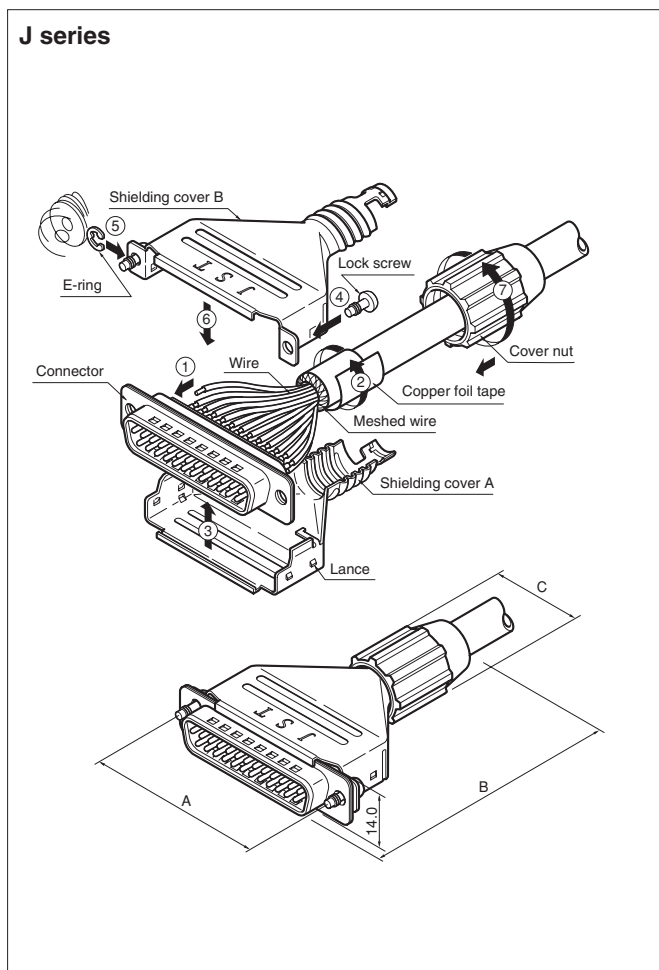

Assembly procedure

1. Connect wires to the connector by soldering or crimping.
2. Fold back the braided shielding wire along the outside insulation and wind the copper foil tape around the shielding wire.
3. Install the connector into shielding cover A.
4. Screw the lock screws onto shielding cover B.
5. Install the E-rings.
6. Align shielding cover B with shielding cover A and press shielding cover B until it engages the lances of shielding cover A.
7. Tighten the cover nut until the predetermined position is reached.

Note: For details of the J-cover assembly procedure, please refer to the processing specifications separately available. The shielding effect of the J-cover is critically dependent on proper assembly.

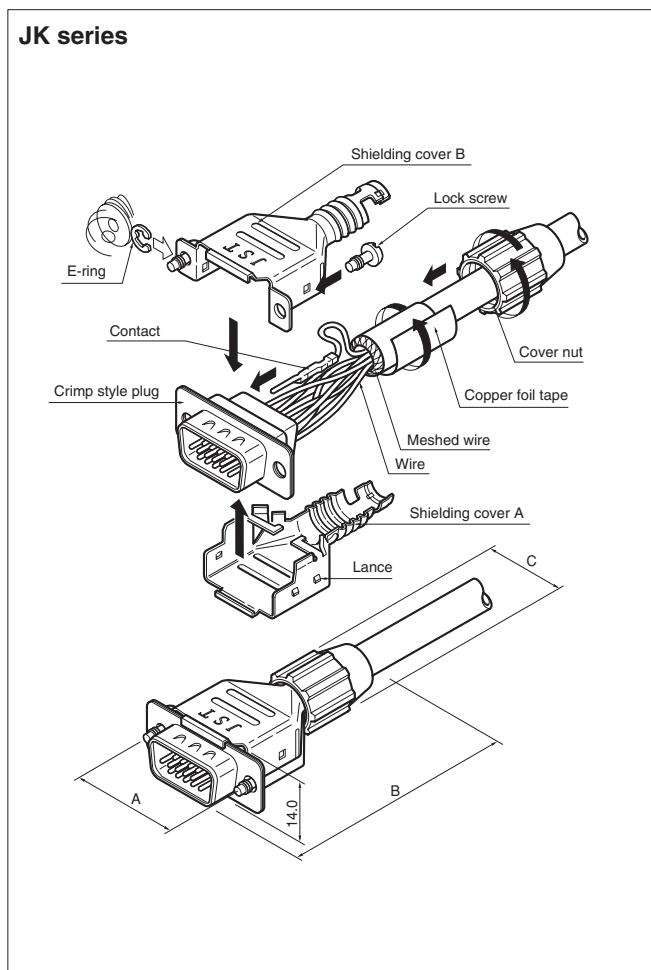

Dimensions after assembly

Circuits		Dimensions (mm)		
J series	JK series	A	B	C
9	15	24.99	(49.0)	13.6
15	—	33.32	(53.0)	13.6
25	—	47.04	(64.5)	16.4
37	—	63.50	(78.5)	18.9



D SUBMINIATURE J&JK SERIES

Accessories/EMI prevention overmolding cover

MOLD COVER



Features

- This cover completely encloses all wire connections to the connector, and its braided wire crimp section ensures a reliable ground connection. The result is excellent shielding.
- This cover is sturdy enough to withstand the high pressure necessary during overmolding. It can thus be finish-molded directly.

- * Compliant with RoHS.
- * Refer to "General Instruction and Notice when using Terminals and Connectors" at the end of this catalog.
- * Contact JST for details.

Applicable cable diameter

Circuits		Cable O.D.(mm)
J series	JK series	
9	15	8.6 ^{±0.2}
15	—	7.6 ^{±0.2}
25	—	8.6 ^{±0.2}

Note: Contact JST for cables other than those listed above.

Ferrule

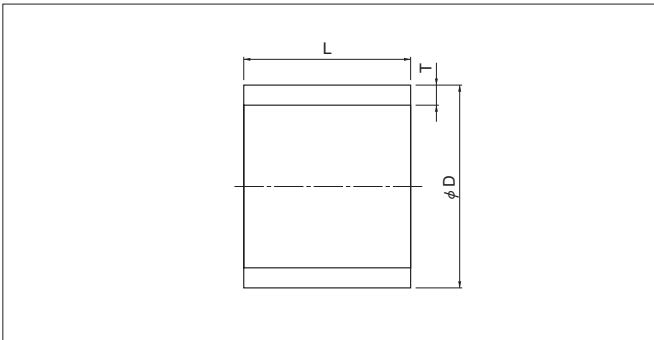

Circuits		Ferrule	Dimensions (mm)		
J series	JK series		φ D	T	L
9 · 25	15	A	8.0	0.5	4.0
		B	11.3	0.6	8.0
15	—	A	7.0	0.5	4.0
		B	10.5	0.6	8.0

RoHS compliance

Mold cover A

JK-MC15A-3
J-MC15A

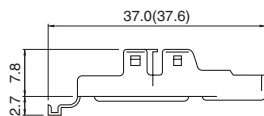
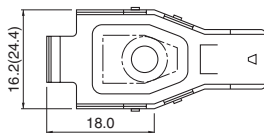

*Dimensions in () are those for the J-MC15A.

J-MC25A-4

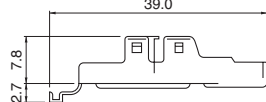
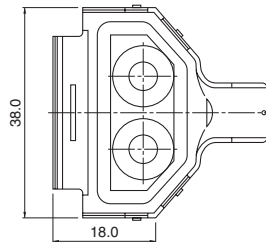

Mold cover B

JK-MC15B-3
J-MC15B

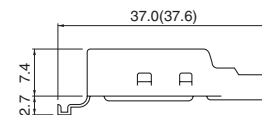
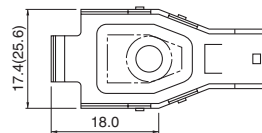

*Dimensions in () are those for the J-MC15B.

J-MC25B-4

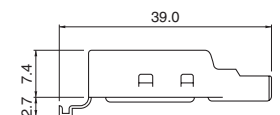
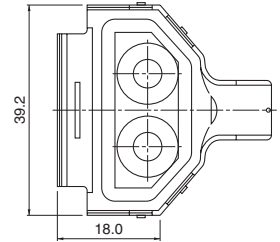

RoHS compliance

D SUBMINIATURE CONNECTOR J&K SERIES

Mold cover assembly procedure

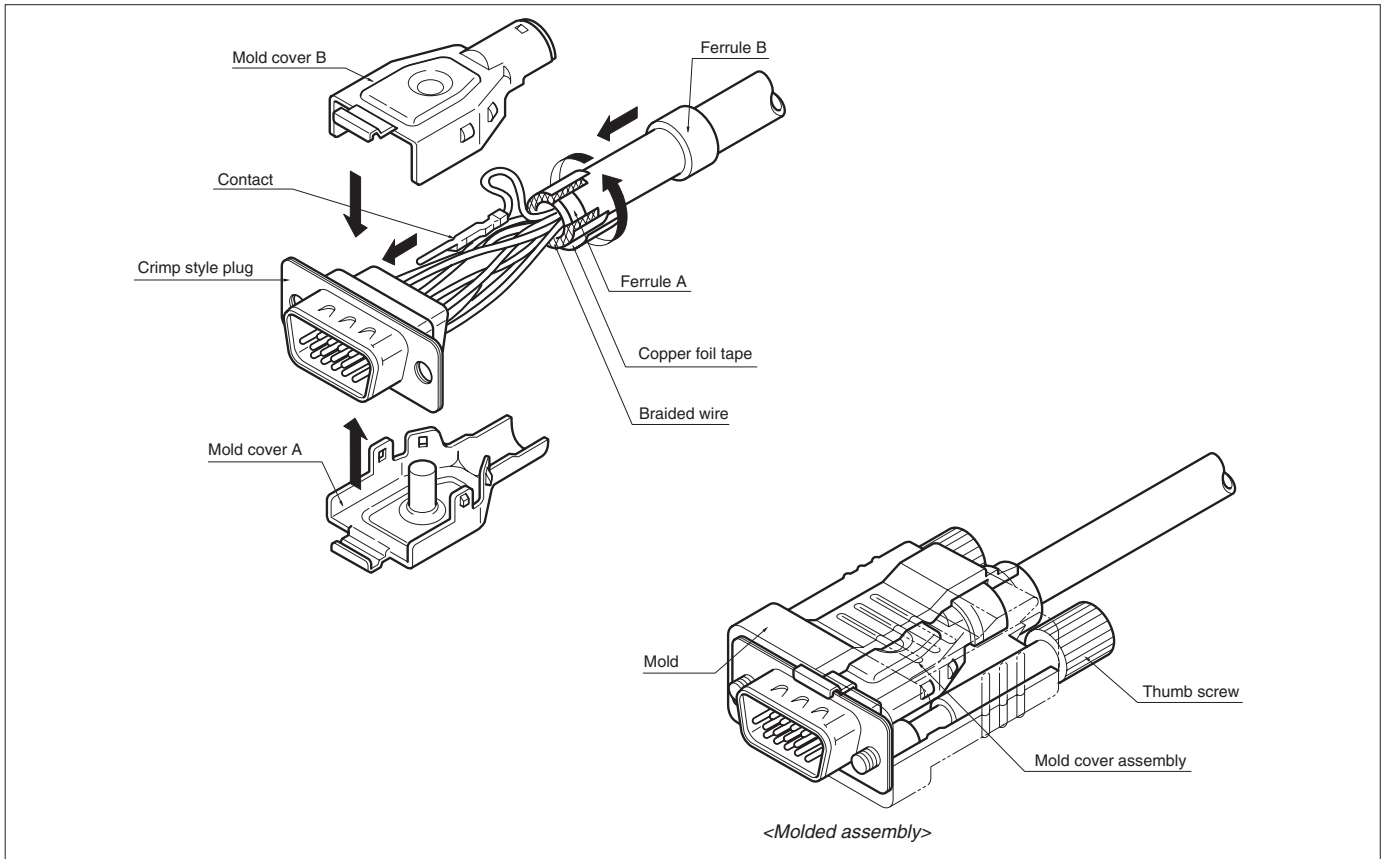

Note: Contact JST for thumb screws.

Assembly procedure

1. Processing braided shielding wire

Pass the cable through ferrule B and remove the insulation at the end of the cable. Install ferrule A and fold back the braided shielding wire along the outside insulation. Then wind the copper foil tape around the shielding wire.

2. Connecting the wires to the contacts

Connect the wires to the contacts by crimping and insert the contacts into the housing.

3. Assembling the mold covers

Align mold cover B with mold cover A and press mold cover B until it engages the lances of mold cover A. Install ferrule B over the cable holding section of the cover assembly and crimp ferrule B. This completes the assembly.

Circuits		Parts name	Model No.	Material and Finish	Q'ty / box or bag
J series	JK series				
9	15	Mold cover A	JK-MC15A-3	Steel, copper-undercoated, nickel-plated	500
		Mold cover B	JK-MC15B-3		
		Ferrule A	JK-FL15A-8.0C	Copper, tin-plated	1,000
		Ferrule B	JK-FL15B-11.3		500
15	—	Mold cover A	J-MC15A	Steel, copper-undercoated, nickel-plated	200
		Mold cover B	J-MC15B		
		Ferrule A	J-FL15A-7.0C	Copper, tin-plated	1,000
		Ferrule B	J-FL15B-10.5		500
25	—	Mold cover A	J-MC25A-4	Steel, copper-undercoated, nickel-plated	250
		Mold cover B	J-MC25B-4		
		Ferrule A	JK-FL15A-8.0C	Copper, tin-plated	1,000
		Ferrule B	JK-FL15B-11.3		500

RoHS compliance

Crimping machine, Applicator

Contact	Crimping machine	Applicator		
		Crimp applicator	Dies	Crimp applicator with dies
JK-FL15B-11.3	AP-K2N	MKS-L-RG	MK/JK-MC15	APLMK JK-MC15
J-FL15B-10.5			MK/J-MC15	APLSC JK-MC15



D SUBMINIATURE J SERIES CONNECTOR

Accessories/Covers

EMI SHIELDING ALUMINUM DIE-CAST COVER (for 25-circuit J series connectors)

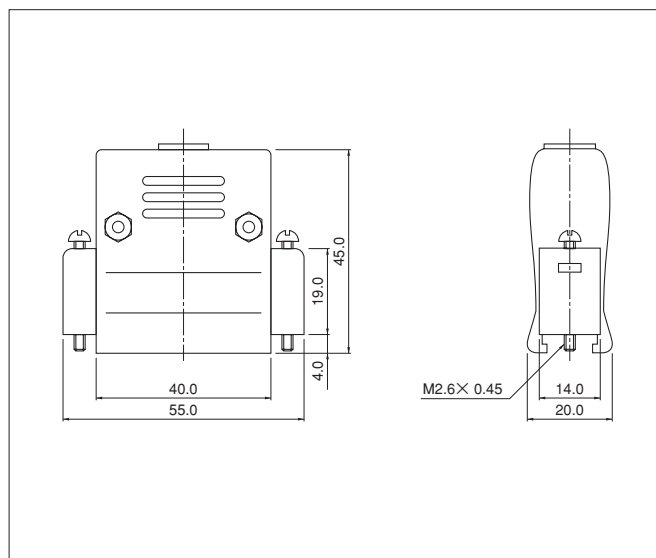

Features

- This cover is made of aluminum die-cast .
- The D subminiature connector and all its wire connections can be completely covered to provide excellent shielding.
- This EMI shielding cover can be used together with the hexagonal and rectangular metric lock screws specified in JIS-C6361. This cover is ideally suited for RS-232C cable connectors.

Model No.	Parts in one set	Cover material	Q'ty / box
JCB-25EM	Cover A - 1 pc. Cover B - 1 pc. Lock screw - 2 pcs. Cable clamp - 2 pcs. Cover screws and nuts - 2 pcs. for each Clamp screws - 2 pcs.	Aluminum die-cast	10

RoHS compliance

- * Compliant with RoHS.
- * Refer to "General Instruction and Notice when using Terminals and Connectors" at the end of this catalog.
- * Contact JST for details.

JIS STYLE PLASTIC COVER (for 25-circuit J series connectors)

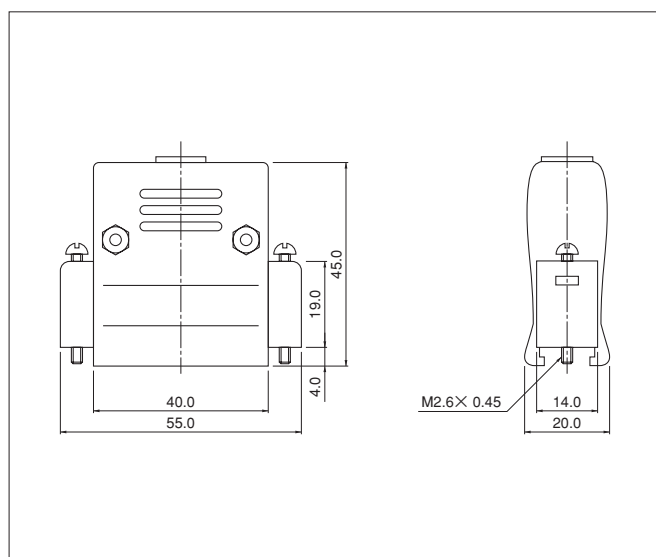

Features

- Molded plastic cover.
- This cover can be used together with the hexagonal and rectangular metric lock screws specified in JIS-C-6361.
- * RoHS compliant products are published.
- * Refer to "General Instruction and Notice when using Terminals and Connectors" at the end of this catalog.
- * Contact JST for details.

Model No.	Parts in one set	Cover material	Q'ty / box
JCB-25M	Covers - 2 pcs. Lock screw - 2 pcs. Cable clamp - 2 pcs. Cover screws and nuts - 2 pcs. for each Clamp screws - 2 pcs.	ABS resin	10

RoHS compliance



D SUBMINIATURE CONNECTOR J·JH·JK & KH SERIES

Accessories/Lock screw block

A variety of accessories are available for the D subminiature connectors.

LOCK SCREW BLOCK



**Hexagonal lock screw block
(inch thread: No.4-40UNC)**

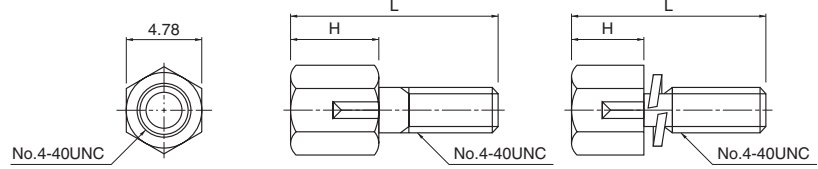

Type A
Type B

Applicable series	J series right angle through-hole type JK series straight through-hole type	JK series right angle through-hole type	J series straight through-hole type	JH series right angle through-hole type KH series right angle through-hole type	Dimension H (mm)	Type	Attachment	Q'ty / box
Dimension L (mm)	13.1	15.0	10.0	11.8				
Model No.	JFS-4S-C1N	KFS-4S-C1N	—	—	5.5	A	Spring washer .. 1 pc. Nut 1 pc.	2,000
	JFS-4S-B1W	KFS-4S-B1W	SFS-4S-B1W	HFS-4S-B1W	4.8		Spring washer .. 1 pc.	
	JFS-4S-C1W	KFS-4S-C1W	SFS-4S-C1W	HFS-4S-C1W	5.5	B	Hexagonal lock screw & spring washer are integrated	
	JFS-4S-B1WM	KFS-4S-B1WM	SFS-4S-B1WM	HFS-4S-B1WM	4.8			
	JFS-4S-C1WM	KFS-4S-C1WM	SFS-4S-C1WM	HFS-4S-C1WM	5.5			

RoHS compliance



**Hexagonal lock screw block
(metric thread: M3)**

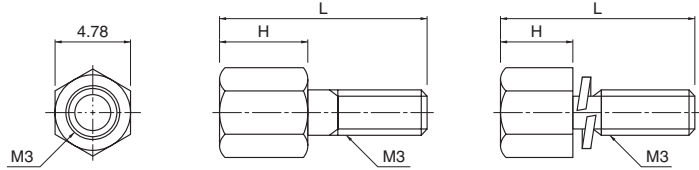

Type A
Type B

Applicable series	J series right angle through-hole type JK series straight through-hole type	JK series right angle through-hole type	J series straight through-hole type	JH series right angle through-hole type KH series right angle through-hole type	Dimension H (mm)	Type	Attachment	Q'ty / box
Dimension L (mm)	13.1	15.0	10.0	11.8				
Model No.	JFS-3S-C1N	KFS-3S-C1N	—	—	5.5	A	Spring washer .. 1 pc. Nut 1 pc.	2,000
	JFS-3S-B1W	KFS-3S-B1W	SFS-3S-B1W	HFS-3S-B1W	4.8		Spring washer .. 1 pc.	
	JFS-3S-C1W	KFS-3S-C1W	SFS-3S-C1W	HFS-3S-C1W	5.5	B	Hexagonal lock screw & spring washer are integrated	
	JFS-3S-B1WM	KFS-3S-B1WM	SFS-3S-B1WM	HFS-3S-B1WM	4.8			
	JFS-3S-C1WM	KFS-3S-C1WM	SFS-3S-C1WM	HFS-3S-C1WM	5.5			

RoHS compliance

D SUBMINIATURE CONNECTOR J·JH·JK&KH SERIES

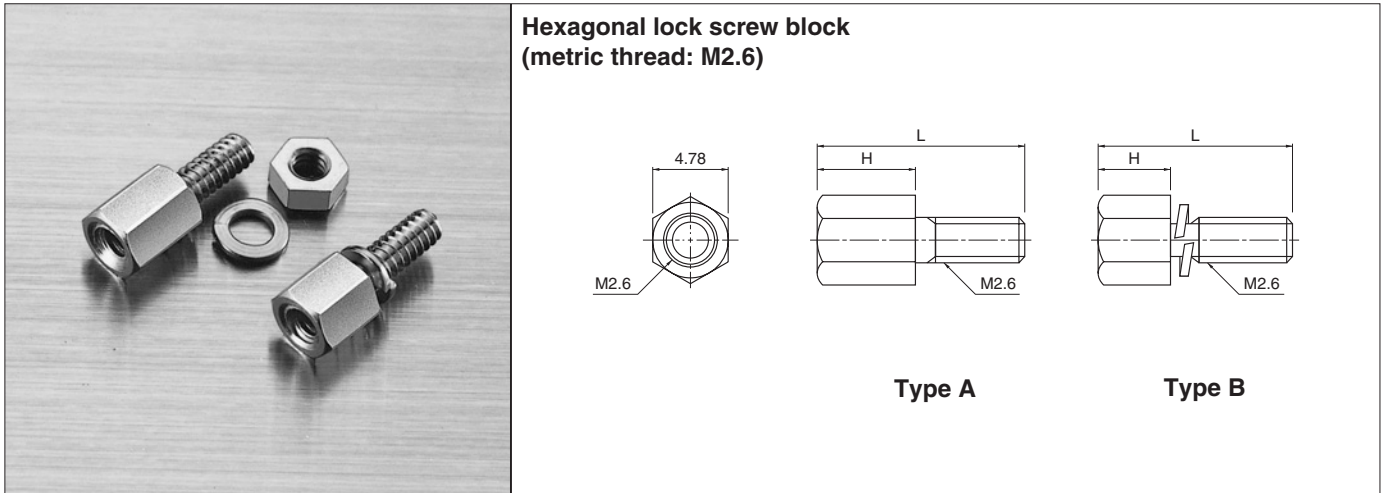

Applicable series	J series right angle through-hole type JK series straight through-hole type	JK series right angle through-hole type	J series straight through-hole type	JH series right angle through-hole type KH series right angle through-hole type	Dimension H (mm)	Type	Attachment	Q'ty / box
Dimension L (mm)	13.1	15.0	10.0	11.8				
Model No.	JFS-2.6S-C1N	KFS-2.6S-C1N	—	—	5.5	A	Spring washer .. 1 pc. Nut 1 pc.	2,000
	JFS-2.6S-B1W	KFS-2.6S-B1W	SFS-2.6S-B1W	HFS-2.6S-B1W	4.8		Spring washer .. 1 pc.	
	JFS-2.6S-C1W	KFS-2.6S-C1W	SFS-2.6S-C1W	HFS-2.6S-C1W	5.5	B	Hexagonal lock screw & spring washer are integrated	
	JFS-2.6S-B1WM	KFS-2.6S-B1WM	SFS-2.6S-B1WM	HFS-2.6S-B1WM	4.8			
	JFS-2.6S-C1WM	KFS-2.6S-C1WM	SFS-2.6S-C1WM	HFS-2.6S-C1WM	5.5			

RoHS compliance

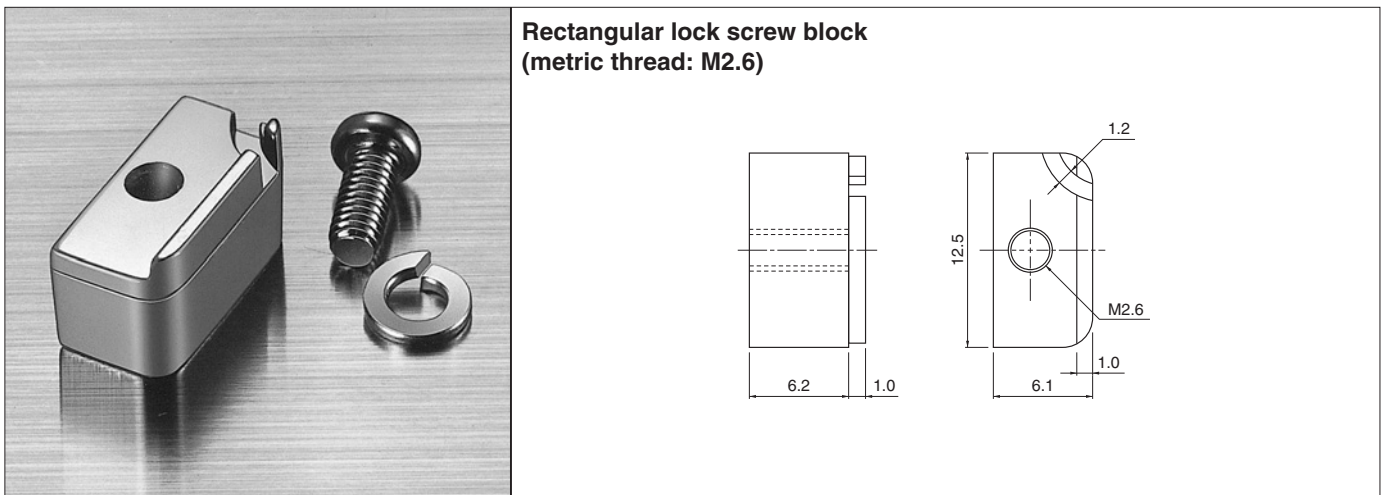

Model No.	Attachment	Q'ty / box
JFS-2.6R-N	Spring washer – 1 pc. Set screw – 1 pc.	1,000

RoHS compliance

D SUBMINIATURE CONNECTOR J·JH·JK&KH SERIES

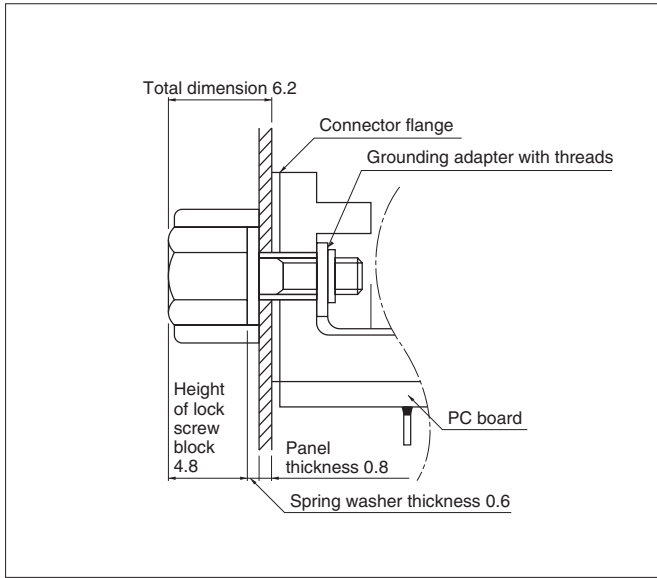

Application examples of hexagonal lock screw blocks

- The resulting total dimension from the connector flange to the top of the hexagonal lock screw block must be 6.2mm after assembly.
- The D subminiature connector can be installed on the Panel by simply tightening the hexagonal lock screw block together with grounding adapter, which has an identical thread to that of the F, G, and H types.

DUST COVER (for receptacles)

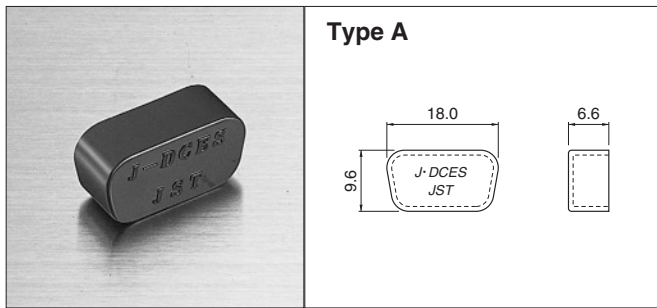

Type	Circuits		Model No.	Q'ty / box
	J series	JK series		
A	9	15	J-DCES	1,000
B			J-DCES-1	
Material				
PA, UL94V-0, black				

RoHS compliance

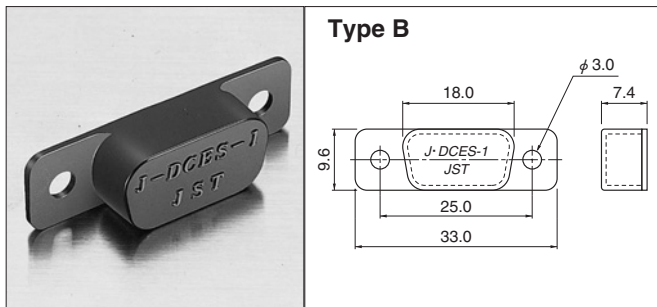

EXTRACTION TOOL



With this tool, contacts (connected to wires by crimping) can be easily removed if they are improperly inserted into plug and receptacle housings.

Applicable Connector		Model No.
J series		DEJ-0.3
JK series	Plug	KEJ-0.7
	Receptacle	KEJ-0.4