

24-hour/Weekly Time Switch

H2F

Up to 96 ON/OFF Cycles from DIN-sized (72 x 72 mm) Timer

- Easy setting with color-coded programming tabs.
- Choose 24-hour or 1-week models with either SPST-NO or SPDT control outputs.
- Minute dial assures accurate settings.
- Models with memory protection available.
- Control outputs can be manually turned ON/OFF.
- Designed for surface, flush, or track mounting.



Ordering Information

Mounting method	Control output	24-hour operation		1-week operation
		Synchronous motor	Quartz motor (with memory protection)	Quartz motor (with memory protection)
Flush	SPST-NO	H2F-D	H2F-DM	H2F-WM
	SPDT	H2F-DC	H2F-DMC	H2F-WMC
Surface/track	SPST-NO	H2F-DF	H2F-DMF	H2F-WMF
	SPDT	H2F-DFC	H2F-DMFC	H2F-WMFC

■ Accessories (Order Separately)

Extra programming tabs	1 pair for each ON/OFF (see note)	Y92S-21
Rechargeable Battery		Y92S-22

Note: 24-hour type is supplied with three pairs of programming tabs.
1-week type is supplied with seven pairs of programming tabs.

Specifications

■ Time Ranges

Operation period	Minimum division	Minimum set time	Maximum set time
24-hour	15 min	30 min	23 hrs 45 min
1-week	1 hr	2 hrs	166 hrs

■ ON/OFF Cycle

Operation period	24-hour	1-week
Maximum cycles	96	84

■ Ratings

Rated supply voltage	Synchronous motor: 100/110/120 VAC, 200/220/240 VAC (50/60 Hz) (see note) Quartz motor: 100 to 240 VAC (50/60 Hz)
Operating voltage range	85% to 110% of rated supply voltage
Power consumption	Synchronous motor: 3 VA max. Quartz motor: 1 VA max. at 100 to 120 VAC, 4 VA max. at 200 to 240 VAC
Control outputs	15 A at 250 VAC, resistive load, SPST-NO, SPDT

Note: Refer to *Precautions*.

■ Characteristics

Item	24-hour operation		1-week operation
	Synchronous motor	Quartz motor	
Accuracy of operating time (see note 1)	±3 min max.		±30 min max.
Influence of voltage			±30 min max.
Influence of temperature			±30 min max.
Setting error (see note 2)	±3 min max.		±30 min max.
Cyclic error	±3 min max.		±30 min max.
Memory protection against power failure	---	180 hrs min. (see note 3)	
Insulation resistance	100 MΩ min. (at 500 VDC)		
Dielectric strength	2,000 VAC, 50/60 Hz for 1 min (between current-carrying terminals and non-current-carrying metal parts) 1,000 VAC, 50/60 Hz for 1 min (between non-continuous contacts)		
Vibration resistance	Destruction: 16.7 Hz, 4-mm double amplitude Malfunction: 10 to 55 Hz, 0.5-mm double amplitude		
Shock resistance	Destruction: 1,000 m/s ² (approx. 100G) Malfunction: 200 m/s ² (approx. 20G)		
Ambient temperature	Operating: -10°C to 55°C		
Ambient humidity	Operating: 35% to 85%		
Life expectancy	2 years min. (approx. 10,000 operations min.)		
Approved standards	UL (File No. E52800), CSA (File No. LR22310)		
Weight	Flush mounting: approx. 150 g Surface mounting: approx. 200 g		

- Note:**
1. Accuracy of operating time of when the timer is ON or when the timer is OFF.
 2. Difference between the set and actual operation time with the pointer set to the present time.
 3. When the timer is used for the first time after energization of 72 hrs.

Dimensions

Note: All units are in millimeters unless otherwise indicated.

Mounting Dimensions

Surface Mounting: H2F-DF/-DMF/-WMF

Track Mounting: H2F-DFC/-DMFC/-WMFC

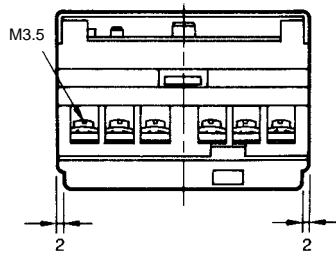
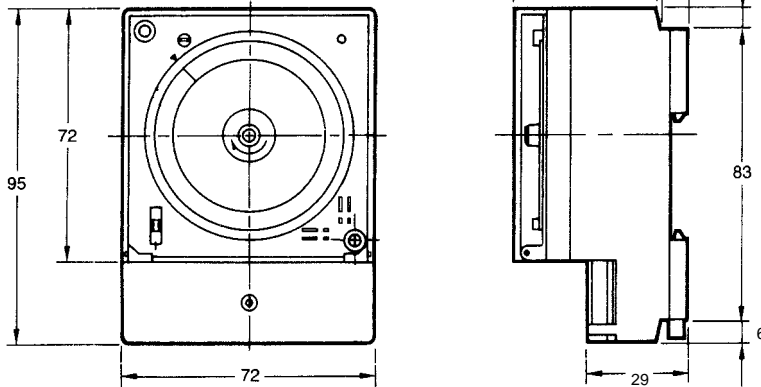

Mounting Holes

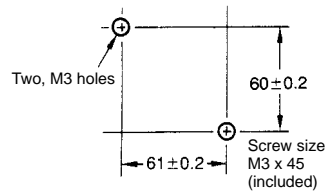

Flush Mounting: H2F-D/-DM/-WM/-DC/-DMC/-WMC

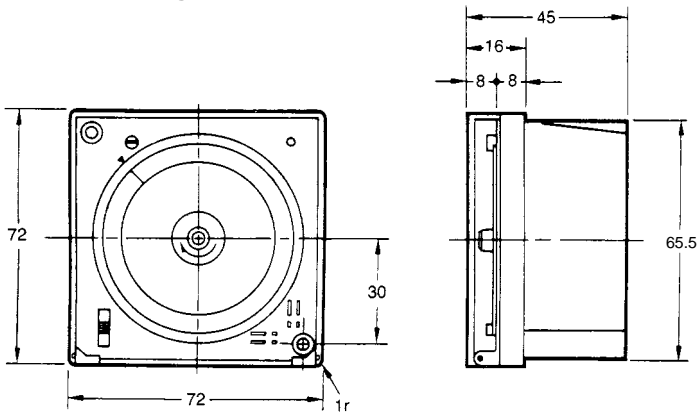

Panel Cutout

Recommended panel thickness: 3.2 mm

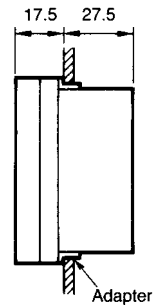
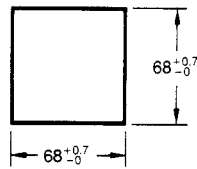
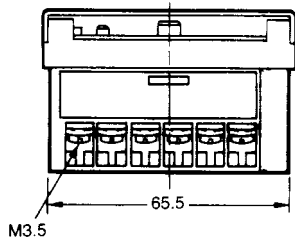

Note: The mounting adapter and screws are included.

Installation

■ Connections

Synchronous Motor Model (SPST-NO Output)

H2F-D

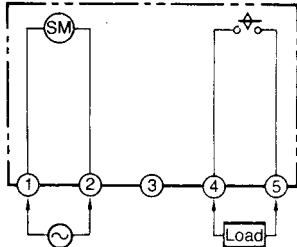

100/110/120 VAC

H2F-DF

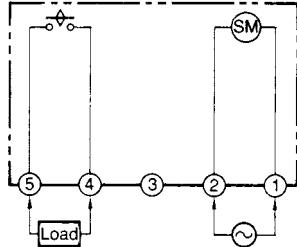

100/110/120 VAC

(SPDT Output)

H2F-DC

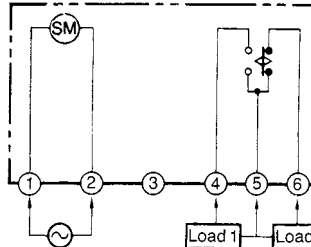

100/110/120 VAC

H2F-DFC

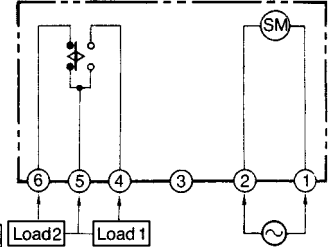

100/110/120 VAC

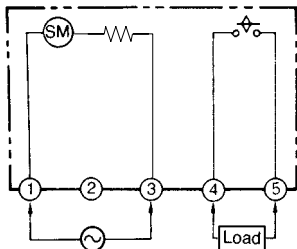

200/220/240 VAC

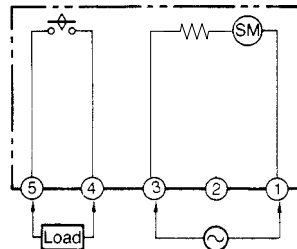

200/220/240 VAC

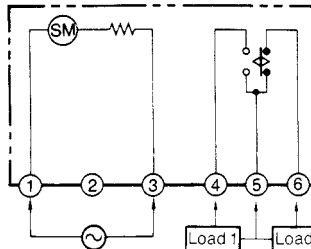

200/220/240 VAC

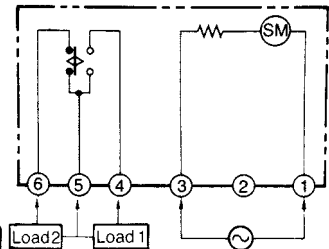

200/220/240 VAC

Quartz Motor Model (SPST-NO Output)

H2F-DM/H2F-WM

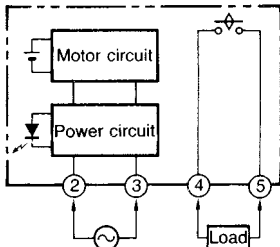

100 to 240 VAC

H2F-DMF/H2F-WMF

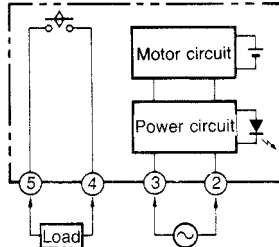

100 to 240 VAC

(SPDT Output)

H2F-DMC/WMC

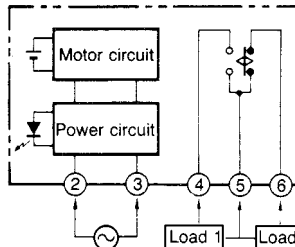

100 to 240 VAC

H2F-DMFC/WMFC

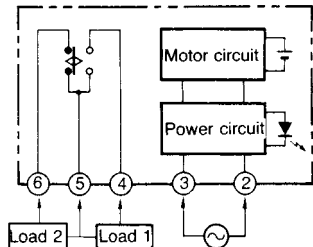

100 to 240 VAC

Note: Connect an independent power source to the load.

Precautions

Flush Mounting

1. To mount the adapter to the panel cutout, first deform the adapter by pushing it on the two opposing corners (as indicated by arrows A). Then push part B into the cutout (i.e., toward the back of the panel).

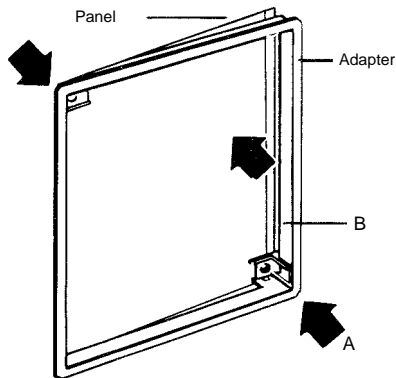

2. After the adapter is mounted, insert the timer as shown in the figure below. Secure the timer by tightening the two mounting screws (M3 x 45) included as accessories.

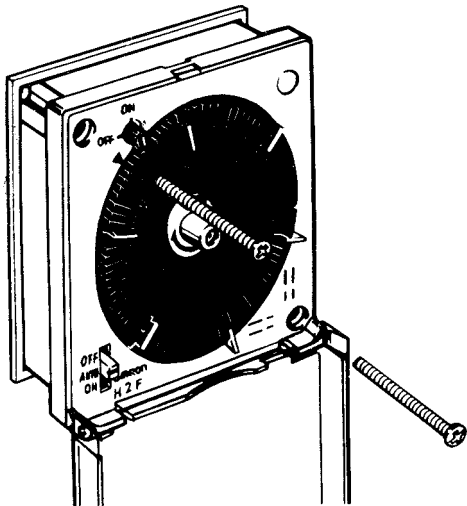

3. If the lead wires have been connected to the timer from the front of the panel before the timer is mounted in the panel, engage the timer to part A of the adapter and push it in the direction of B. Then tighten the two screws as described in 2.

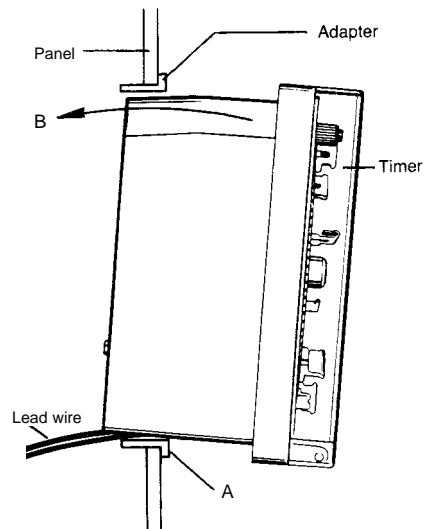

Time Setting

To set the time, turn the center knob clockwise to the correct time. Turning it counterclockwise or turning it with your fingers hooked on the setting bracket may cause a malfunction.

Set the hour to the arrow on the upper left corner of the front panel and the minute, to the arrow on the center knob.

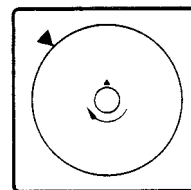

Use the gold setting tabs to set the ON time and the silver ones to set the OFF time. Position the thick leg of the tab toward the outside of the dial and insert the tab securely into the groove on the dial.

For ON (gold)



For OFF (silver)



Outside ← → Inside

Outside ← → inside

Three pairs of setting tabs are attached. Store the spare tabs in the compartment at the lower right corner of the front panel.

Manual Switch

SPST-NO Output

A 3-position selector switch, located at the lower left corner of the front panel, determines output operation. In the OFF position, the control output is forcibly turned OFF regardless of the setting of the programming tabs. Set to the AUTO position, the output is turned ON and OFF according to the settings of the programming tabs. In the ON position, the output is forcibly turned ON regardless of the setting of the programming tabs.

SPDT Output

When the manual switch at the lower left corner of the front is set to the OFF position, both load 1 (connected across terminals 4 and 5) and load 2 (across 5 and 6) are turned OFF.

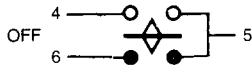

When it is set to the AUTO position, the output is turned ON and OFF according to the setting of the programming tabs.

When the manual switch is set to the ON position, load 1 (connected across terminals 4 and 5) is turned ON and load 2 (across 5 and 6) is turned OFF.

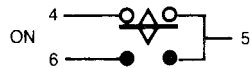

Output Indicator

The output indicator at the upper left corner of the front panel shows the status of the output when the manual switch is set to the AUTO position.

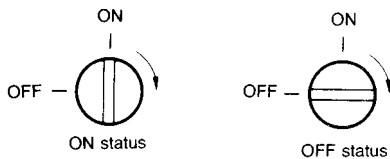

In addition, the output can be manually turned ON or OFF by rotating the knob clockwise (in the arrow direction). The knob will not turn counterclockwise.

Note on H2F-D, -DF Series (synchronous motor versions)

Before using the timer, select the appropriate frequency of your area by the frequency selector switch provided on the upper part of the rear panel.



Upper part of rear panel
(cycles per second)

H2F-□M Series (Quartz Motor Models)

Battery

Remove the battery cover on the rear panel of the H2F, load the provided Battery into the battery box, then turn ON the H2F. Be sure to load the Battery before using the H2F. If the Battery is not loaded, the power indicator will flash and the H2F will not work properly.

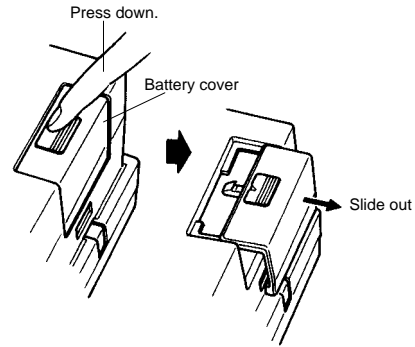

Be sure to load the Battery with the correct polarity. The polarity is indicated in the battery box. After loading the Battery, be sure to place the cover on the battery box.

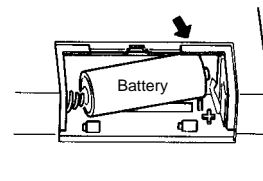

The Battery is fully charged before shipment. The Battery may lose its charge while the Battery is stored. Therefore, there is a backup function that is guaranteed for 180 hours on condition that the Battery is loaded into the H2F and charged continuously for 72 hours. If the Battery has no charge, the H2F may not operate immediately after it is turned ON. In that case, continue providing power to the H2F for three or more minutes before setting the time.

If the H2F is turned ON and OFF frequently, the Battery life will be greatly reduced. Use the H2F with a continuous supply of power.

The Battery has a life of approximately three years. If three years have passed since the Battery was loaded, replace the Battery as soon as possible with a AAAA-size NiCd rechargeable battery.

If the H2F is idle over a long time, unload the Battery from the H2F and store the Battery separately in order to prevent the Battery from being overly discharged.

ALL DIMENSIONS SHOWN ARE IN MILLIMETERS.

To convert millimeters into inches, multiply by 0.03937. To convert grams into ounces, multiply by 0.03527.

Cat. No. L013-E1-3A **In the interest of product improvement, specifications are subject to change without notice.**

OMRON Corporation

Supervisory Control Devices Division
28th Fl., Crystal Tower Bldg.,
1-2-27, Shiromi, Chuo-ku,
Osaka 540-6028 Japan
Phone: (81)6-949-6035 Fax: (81)6-949-6069

Printed in Japan
1298-0.5C (0696)