

SCSI II/III EXTERNAL TERMINATION

230R SERIES (WITH TERMINATING RESISTOR)

■ FEATURES

- Small, lightweight connectors with hybrid IC resistors
- Connectors and resistors are housed in a metal cover, providing shielding against EMI.
- Single-operation lock structure provides easy connection.
- SCSI-3 types with a screw-locked EMI/ESD resistant cover are also available.
- The connectors and resistor circuits conform to the SCSI-2 and SCSI-3 standards recommended by ANSI.

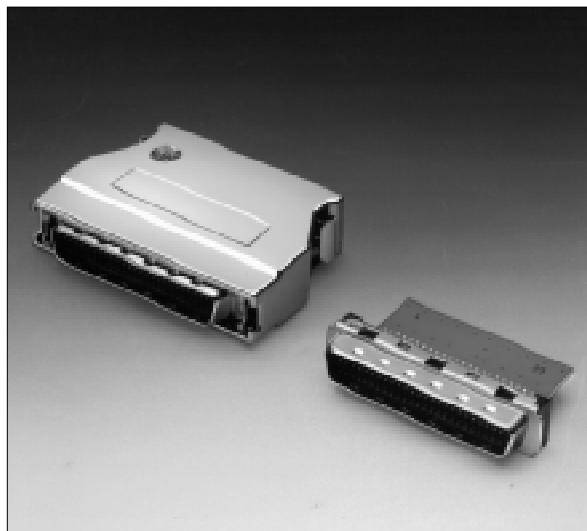

■ MATERIALS AND PLATING

Part number	Materials and plating
Insulator	PPS resin
Conductor materials (plating)	Copper alloy (gold plating)
Shell (plating)	Steel (nickel plating)

■ TYPES AND SPECIFICATIONS

	Single-operation lock type			Screw-lock type	
	Single-ended		Differential	Single-ended	Differential
	Alternative 1	Alternative 2 (With voltage control circuit)		Alternative 2 (With voltage regulator circuit)	
Part number	FCN-239P050-G/E	FCN-239P050-G/C	FCN-239P050-G/D	FCN-239P068-G/CP	FCN-239P068-G/DP
Operating temperature range	-40°C to +85°C	0°C to +50°C	-25°C to +70°C	-0°C to +50°C	-40°C to +85°C
Rated current (connector)	DC 1 A	DC 1 A	DC 1 A	DC 1 A	DC 1 A
Rated voltage (connector)	AC 240 V	AC 240 V	AC 240 V	AC 240 V	AC 240 V

230R Series (With Terminating Resistor)

SINGLE-OPERATION LOCK, SINGLE-ENDED, ALTERNATIVE 1 TYPE DIMENSIONS

Part number: FCN-239P050-G/E

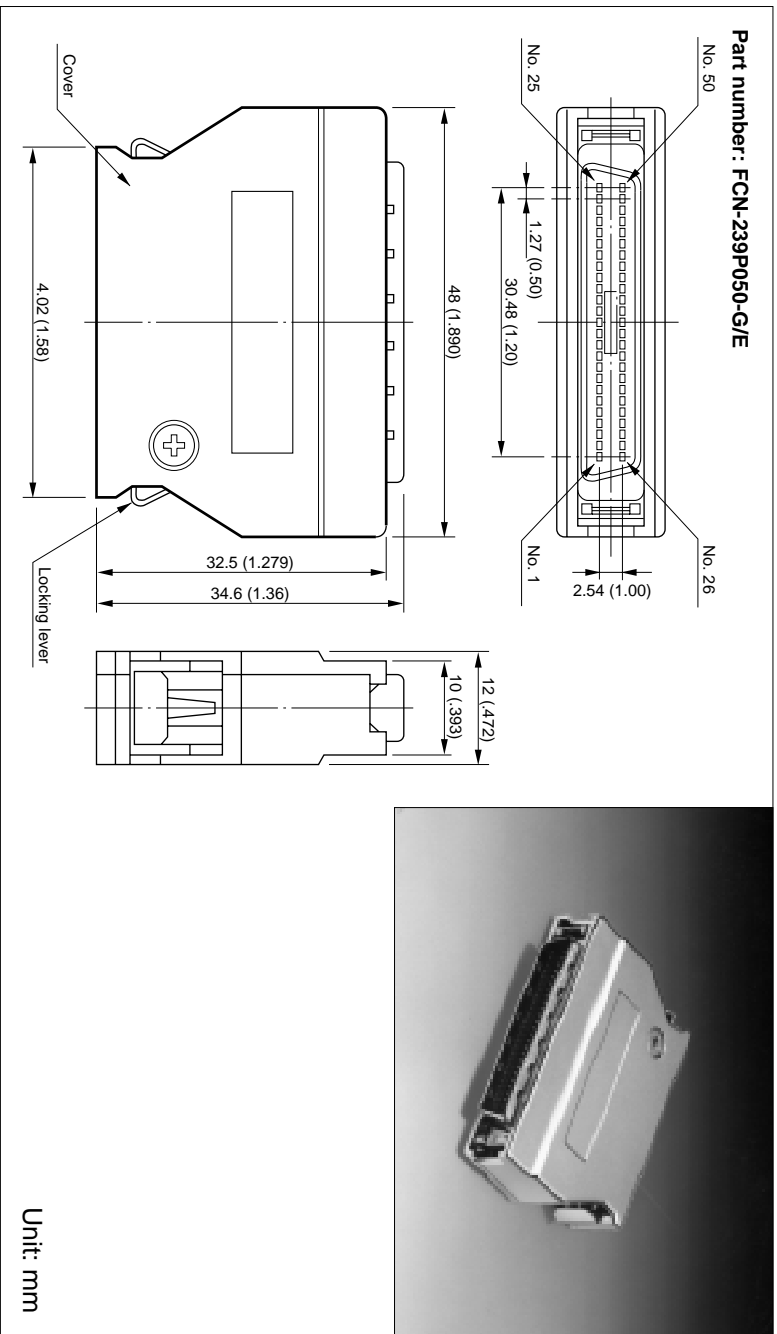

WIRING DIAGRAM

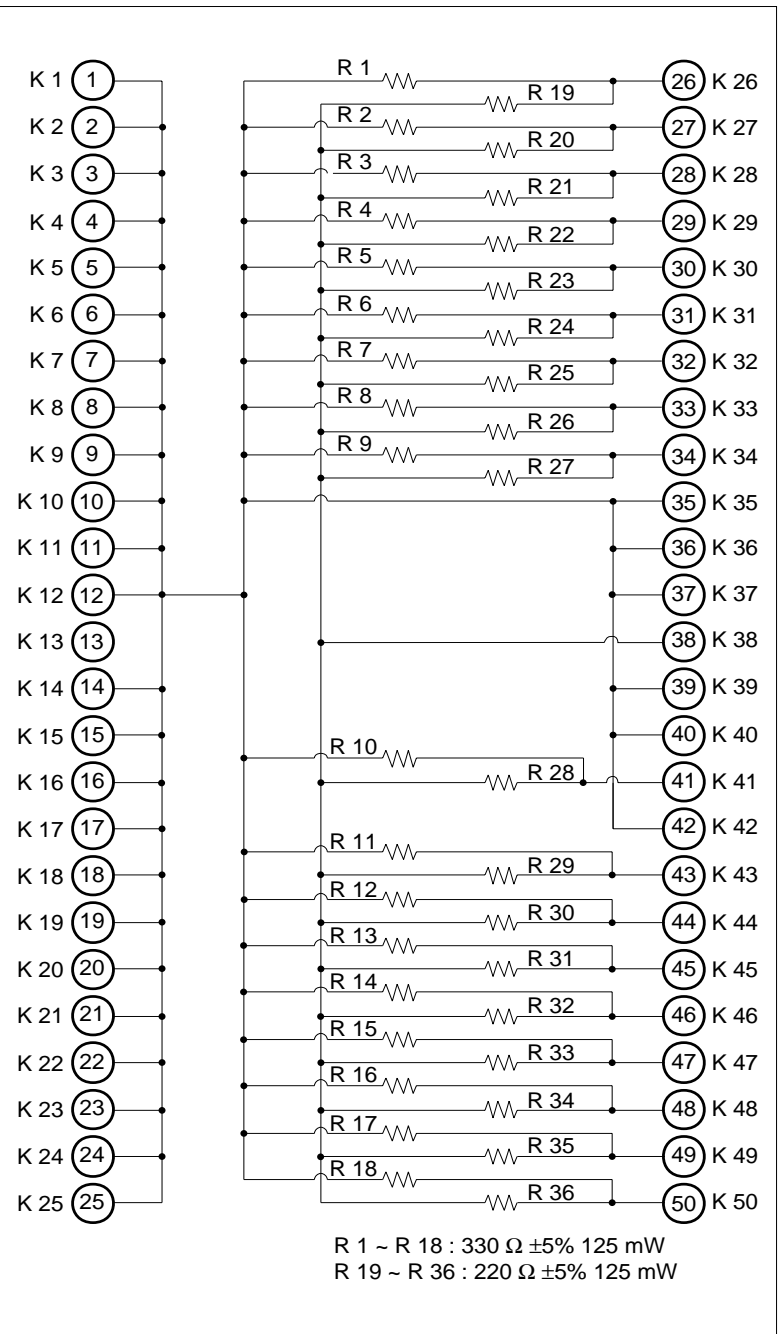

Specifications
subject to change

Dimensions are in millimeters (inches)

www.fcni.fujitsu.com

230R Series (With Terminating Resistor)

SINGLE-OPERATION LOCK, SINGLE-ENDED, ALTERNATIVE 2 WITH VOLTAGE CONTROL CIRCUIT TYPE

■ DIMENSIONS

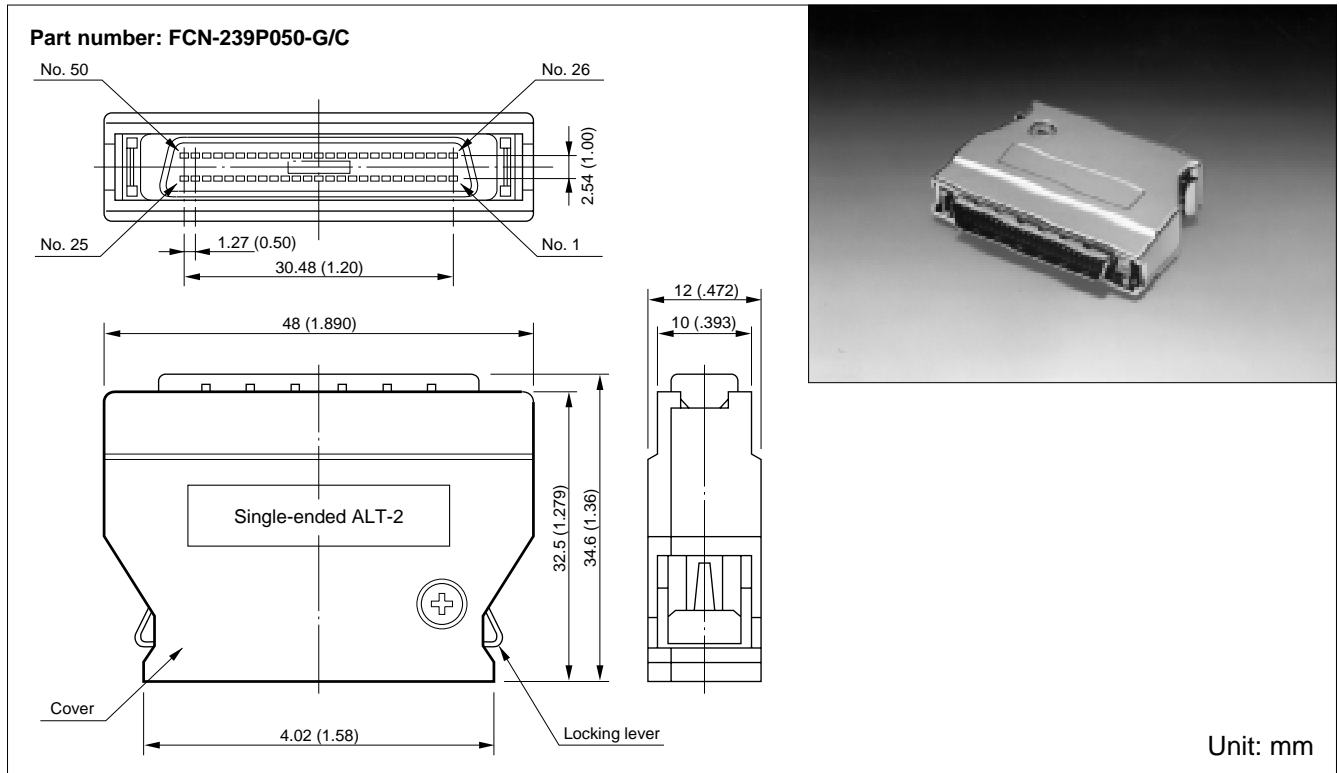

■ WIRING DIAGRAM

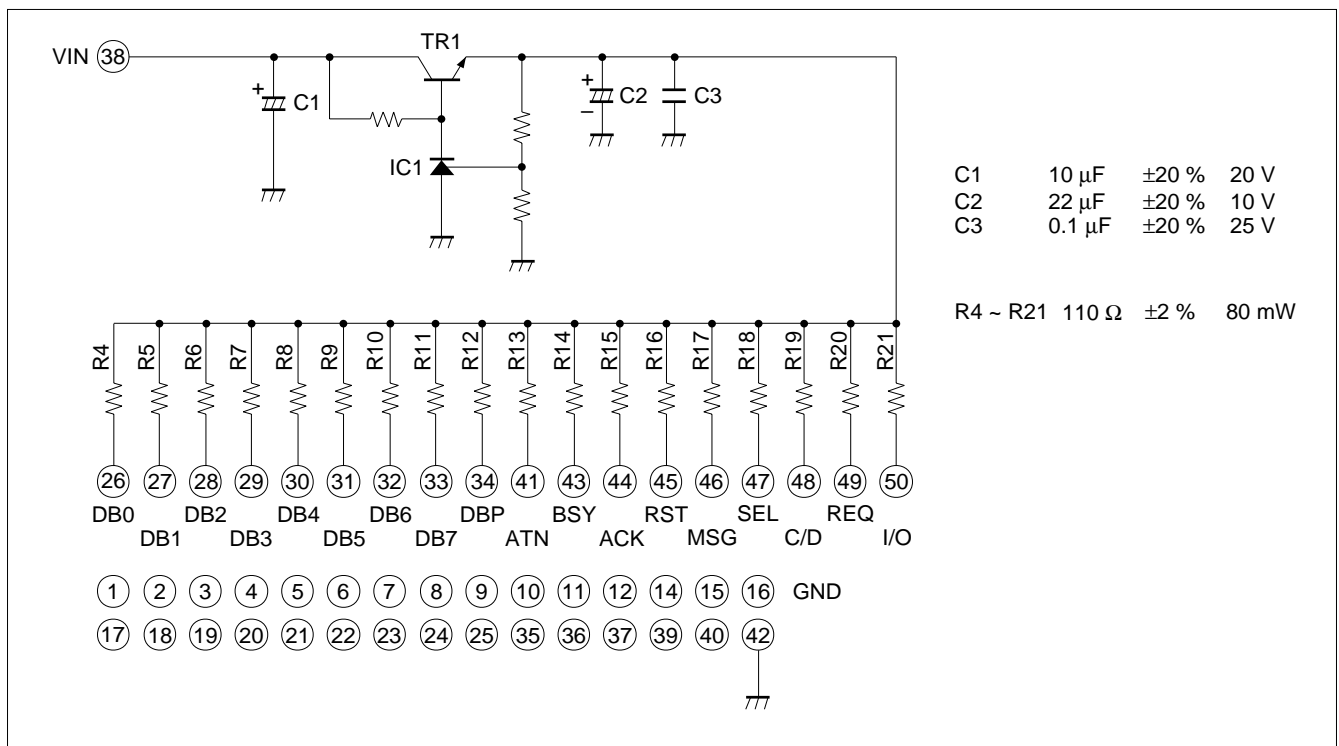

230R Series (With Terminating Resistor)

SINGLE-OPERATION LOCK, DIFFERENTIAL TYPE

■ DIMENSIONS

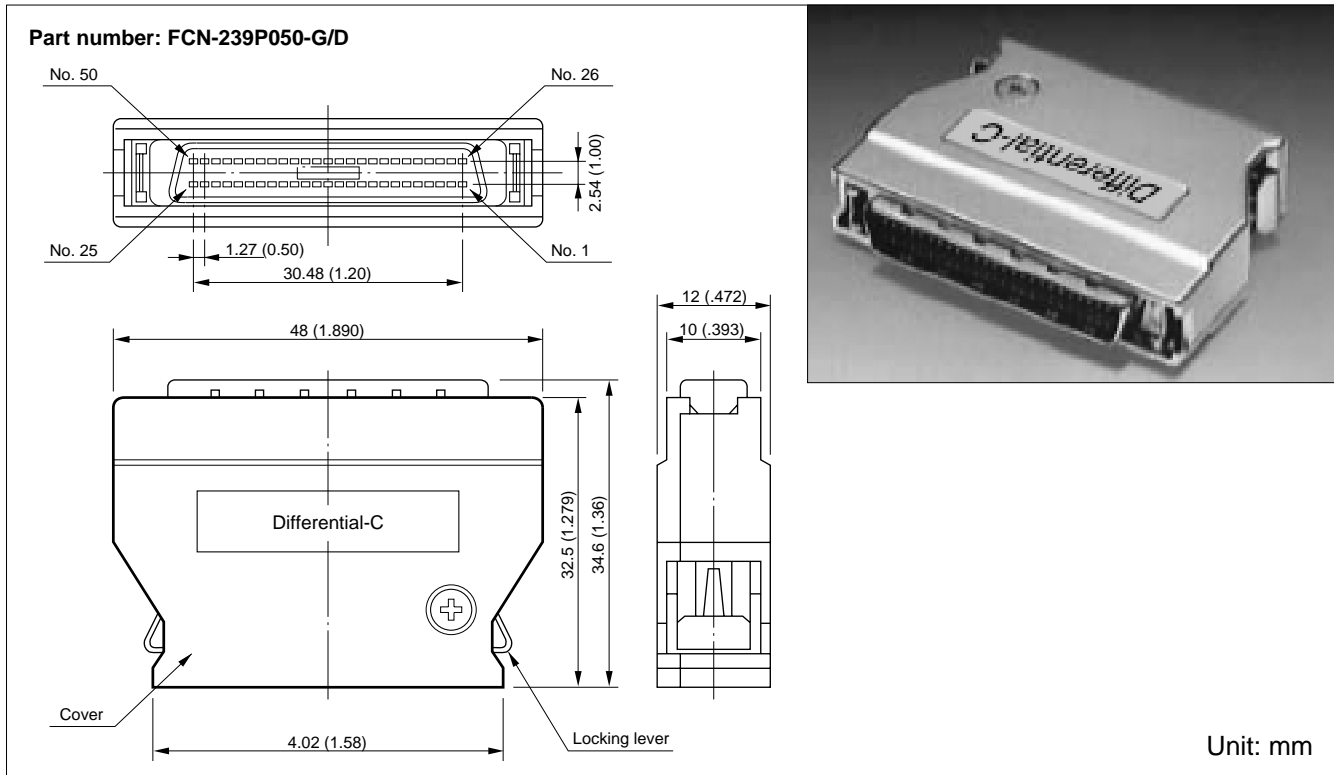

■ WIRING DIAGRAM

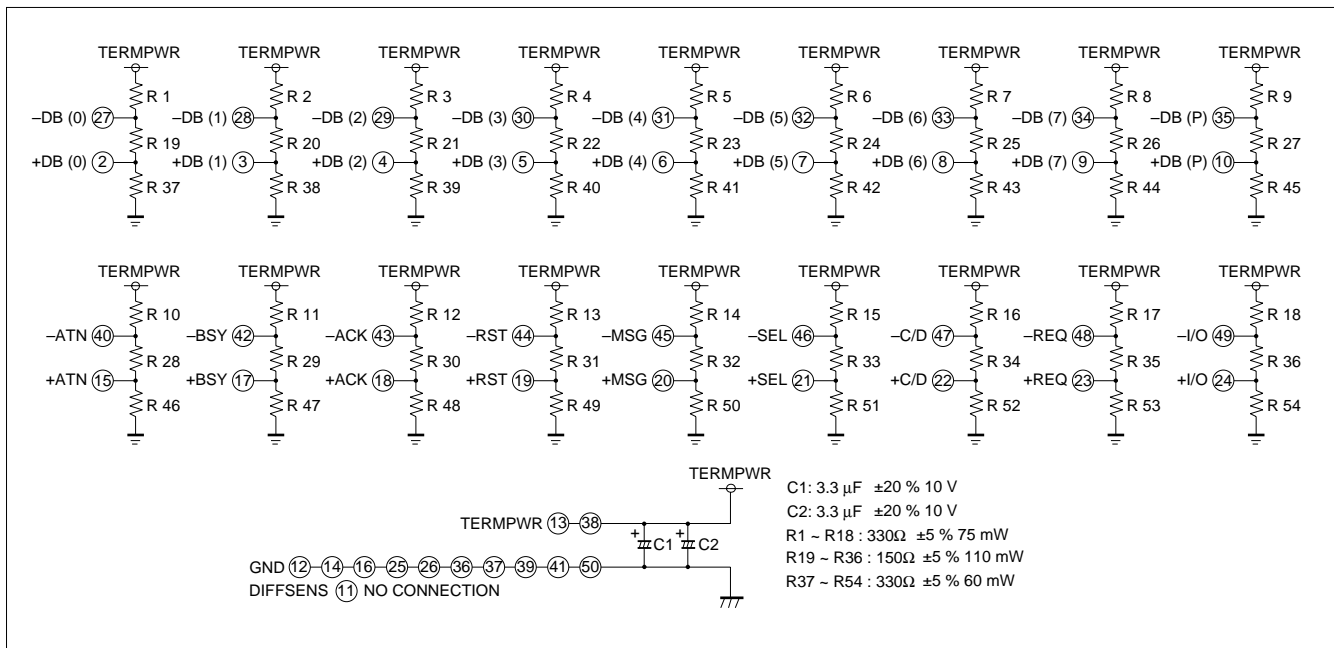

230R Series (With Terminating Resistor)

Fujitsu Components International Headquarter Offices

Japan

Fujitsu Component Limited
Gotanda-Chuo Building
3-5, Higashigotanda 2-chome, Shinagawa-ku
Tokyo 141, Japan
Tel: (81-3) 5449-7010
Fax: (81-3) 5449-2626
Email: promothq@ft.ed.fujitsu.com
Web: www.fcl.fujitsu.com

North and South America

Fujitsu Components America, Inc.
250 E. Caribbean Drive
Sunnyvale, CA 94089 U.S.A.
Tel: (1-408) 745-4900
Fax: (1-408) 745-4970
Email: marcom@fcai.fujitsu.com
Web: www.fcai.fujitsu.com

Europe

Fujitsu Components Europe B.V.
Diamantlaan 25
2132 WV Hoofddorp
Netherlands
Tel: (31-23) 5560910
Fax: (31-23) 5560950
Email: info.marketing@fceu.fujitsu.com
Web: www.fceu.fujitsu.com

Asia Pacific

Fujitsu Components Asia Ltd.
102E Pasir Panjang Road
#04-01 Citilink Warehouse Complex
Singapore 118529
Tel: (65) 375-8560
Fax: (65) 273-3021
Email: fcal@fcal.fujitsu.com
www.fcal.fujitsu.com

© 2001 Fujitsu Components America, Inc. All company and product names are trademarks or registered trademarks of their respective owners. Rev. 09/2001