

FOR BOARD-TO-CABLE CONNECTION

240R SERIES

■ FEATURES

- 1.27 mm (0.050 in.) pitch contact arrangement enables high-density mounting.
- Bellows contacts ensure stable contact preventing pins from bending. The bellows contacts also have excellent stability with repeated insertion and extraction.
- Cables and connectors are assembled by discrete wire IDC.
- Connectors on the cable side provide superb EMI shielding/ESD protection with an inner-metal and outer-plastic dual cover.
- Conforms to IEEE 1284.C Interface
- Tails are spaced in a four-row staggered arrangement (2.54 mm × 1.905 mm) (0.100 in. × 0.075 in.) for easy PC board design.



■ SPECIFICATIONS

Item	Specifications
Operating temperature range	-55°C to +85°C
Current rating	DC 1 A
Voltage rating	AC 240 V
Contact resistance	50 mΩ max. (DC 20 mV, 10 mA)
Insulation resistance	1,000 MΩ min. (DC 500 V)
Dielectric withstand voltage	AC 750 V for 1 minute
Applicable wire	AWG #28 and #30 stranded wires with φ0.5 to 0.65 mm (0.020 to 0.026 in.) insulation diameter

■ MATERIALS

Item	Materials	
Insulator	Polyester (UL94V-0)	
Conductor	Copper alloy	
Plating	Contact	Gold plating
	Terminal	Palladium plating

■ ORDERING CODE

FCN-24 5 D 050-G / E

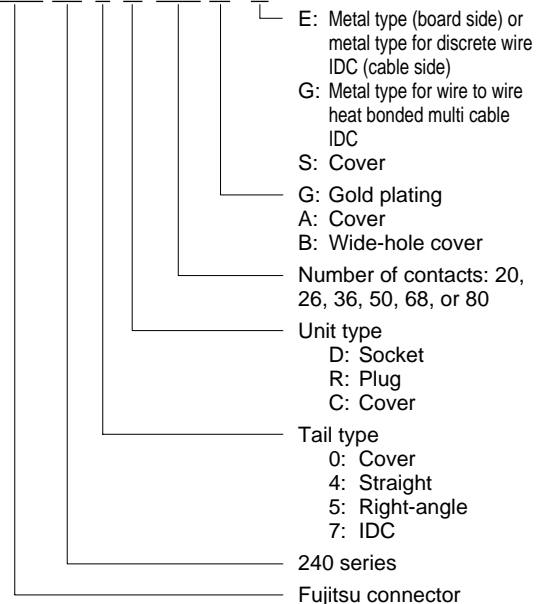

STRAIGHT SOCKET

■ DIMENSIONS

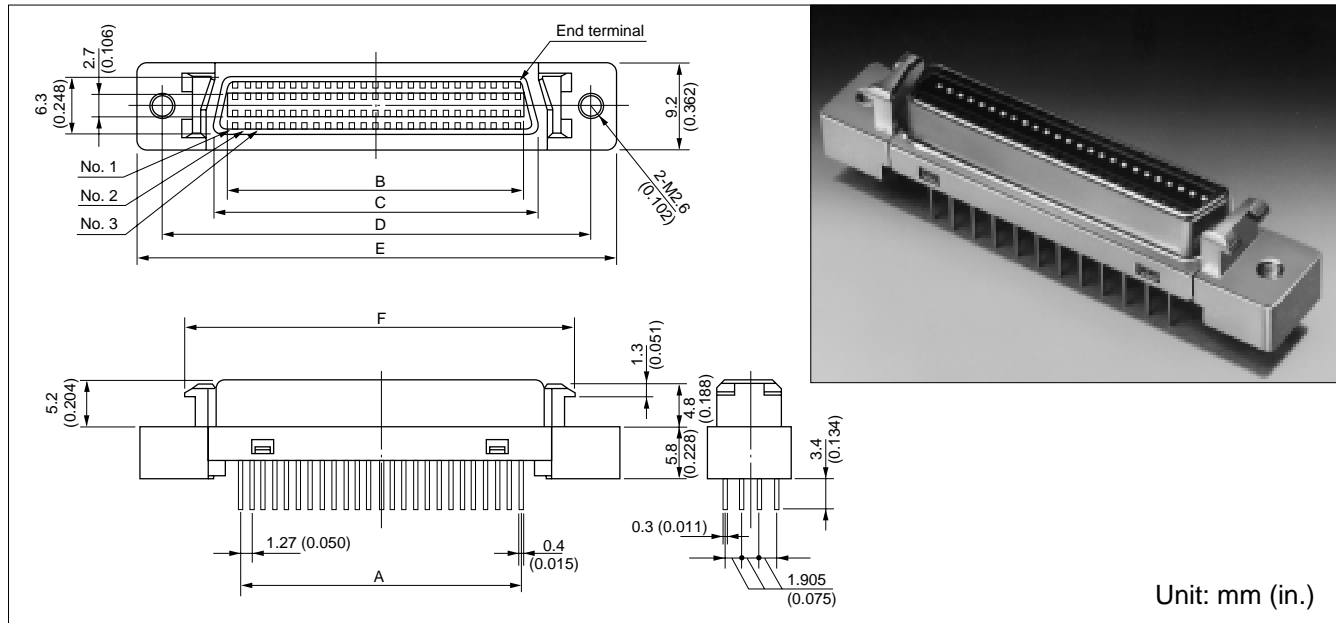

■ MOUNTING HOLE LAYOUT (COMPONENT SIDE)

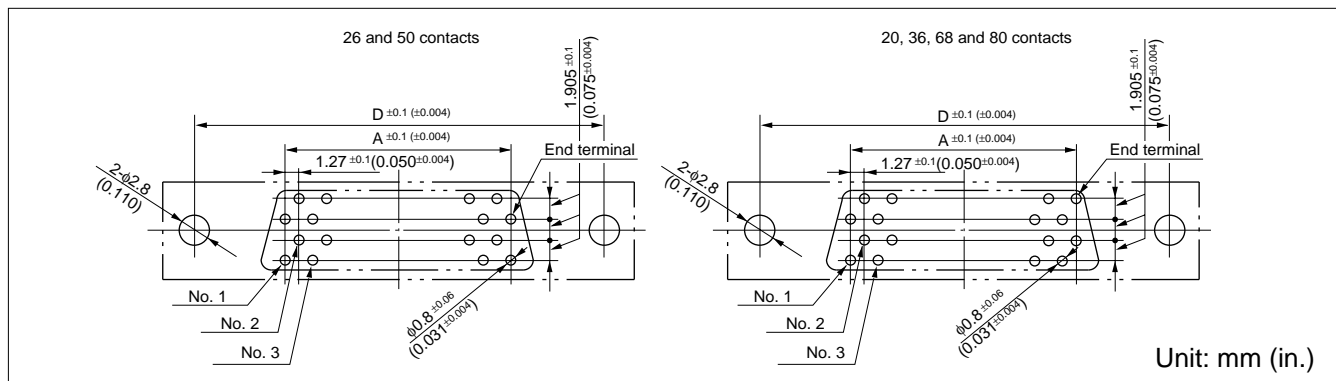

■ PATTERN INHIBITED AREAS

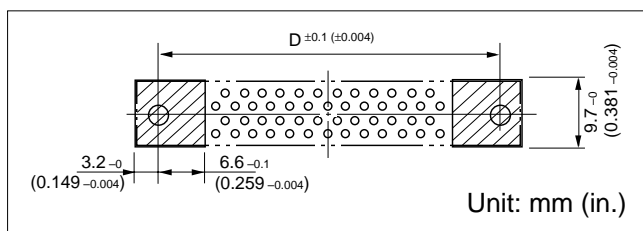

■ RECOMMENDED PANEL DIMENSIONS

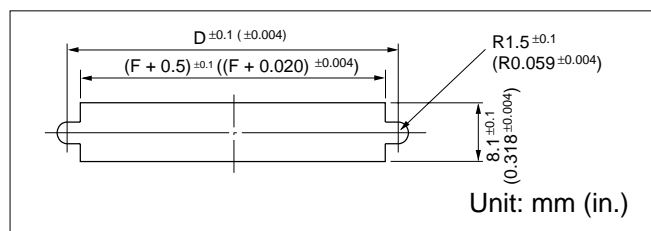

■ PART NUMBERS AND DIMENSIONS

Unit: mm (in.)

Number of contacts	Part number	A	B	C	D	E	F
20	FCN-244D020-G/E	11.43 (0.450)	13.45 (0.529)	16.45 (0.647)	27.45 (1.080)	33.35 (1.312)	23.30 (0.917)
26	FCN-244D026-G/E	15.24 (0.600)	17.26 (0.679)	20.26 (0.797)	31.26 (1.231)	37.16 (1.462)	27.11 (1.067)
36	FCN-244D036-G/E	21.59 (0.850)	23.61 (0.929)	26.61 (1.047)	37.61 (1.480)	43.51 (1.712)	33.46 (1.317)
50	FCN-244D050-G/E	30.48 (1.200)	32.50 (1.279)	35.50 (1.397)	46.50 (1.830)	52.40 (2.062)	42.35 (1.667)
68	FCN-244D068-G/E	41.91 (1.650)	43.93 (1.729)	46.93 (1.847)	57.93 (2.280)	63.83 (2.512)	53.78 (2.117)
80	FCN-244D080-G/E	49.53 (1.950)	51.55 (2.029)	54.55 (2.147)	65.55 (2.580)	71.45 (2.812)	61.40 (2.417)

RIGHT-ANGLE SOCKET [METAL SHELL]

■ DIMENSIONS

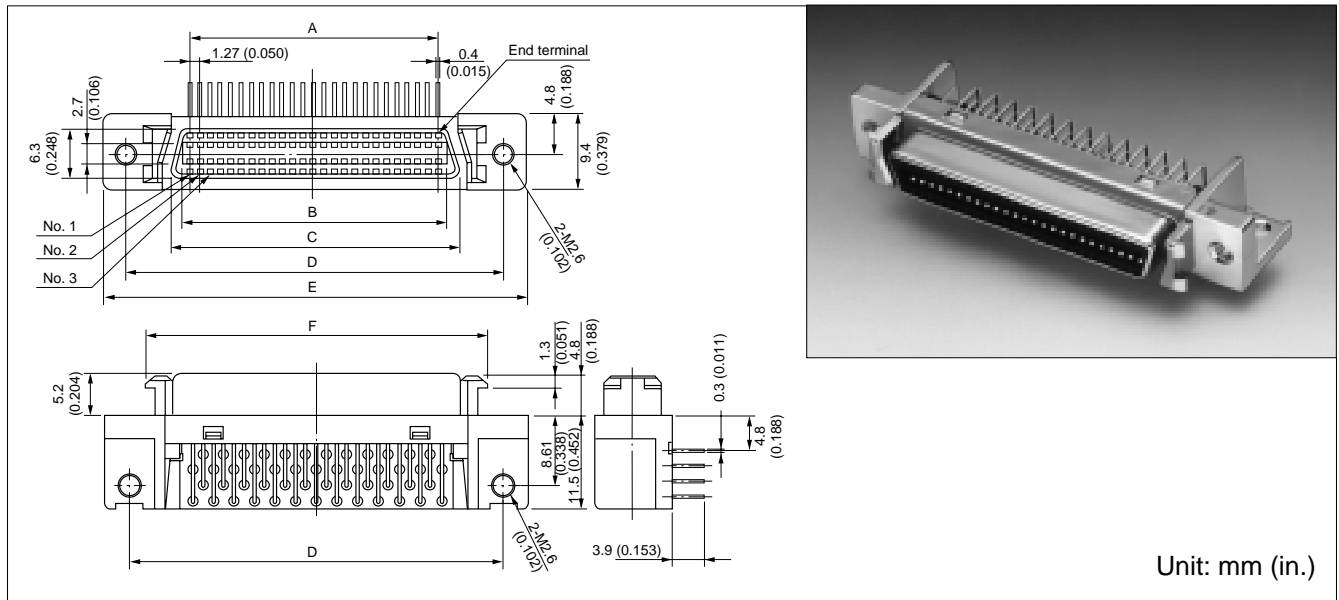

■ MOUNTING HOLE LAYOUT (COMPONENT SIDE)

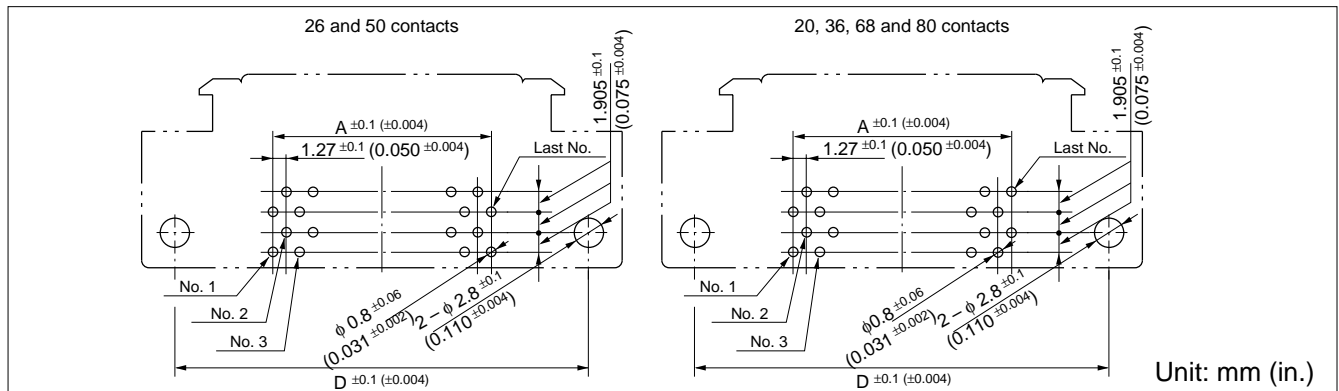

■ PATTERN INHIBITED AREAS

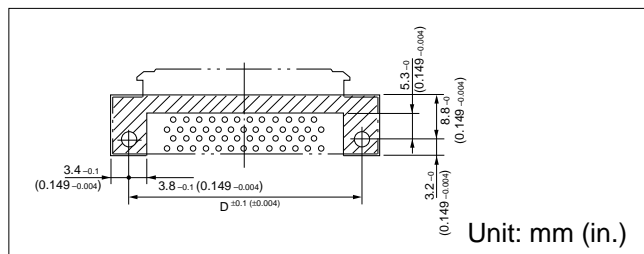

■ RECOMMENDED PANEL DIMENSIONS

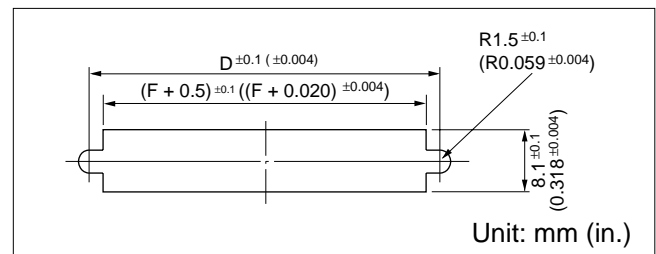

■ PART NUMBERS AND DIMENSIONS

Number of contacts	Part number	A	B	C	D	E	F
20	FCN-245D020-G/E	11.43 (0.450)	13.45 (0.529)	16.45 (0.647)	27.45 (1.080)	33.35 (1.312)	23.30 (0.917)
26	FCN-245D026-G/E	15.24 (0.600)	17.26 (0.679)	20.26 (0.797)	31.26 (1.231)	37.16 (1.462)	27.11 (1.067)
36	FCN-245D036-G/E	21.59 (0.850)	23.61 (0.929)	26.61 (1.047)	37.61 (1.480)	43.51 (1.712)	33.46 (1.317)
50	FCN-245D050-G/E	30.48 (1.200)	32.50 (1.279)	35.50 (1.397)	46.50 (1.830)	52.40 (2.062)	42.35 (1.667)
68	FCN-245D068-G/E	41.91 (1.650)	43.93 (1.729)	46.93 (1.847)	57.93 (2.280)	63.83 (2.512)	53.78 (2.117)
80	FCN-245D080-G/E	49.53 (1.950)	51.55 (2.029)	54.55 (2.147)	65.55 (2.580)	71.45 (2.812)	61.40 (2.417)

RIGHT-ANGLE SOCKET [METAL SHELL] (WITH BOARDLOCKS)

■ DIMENSIONS

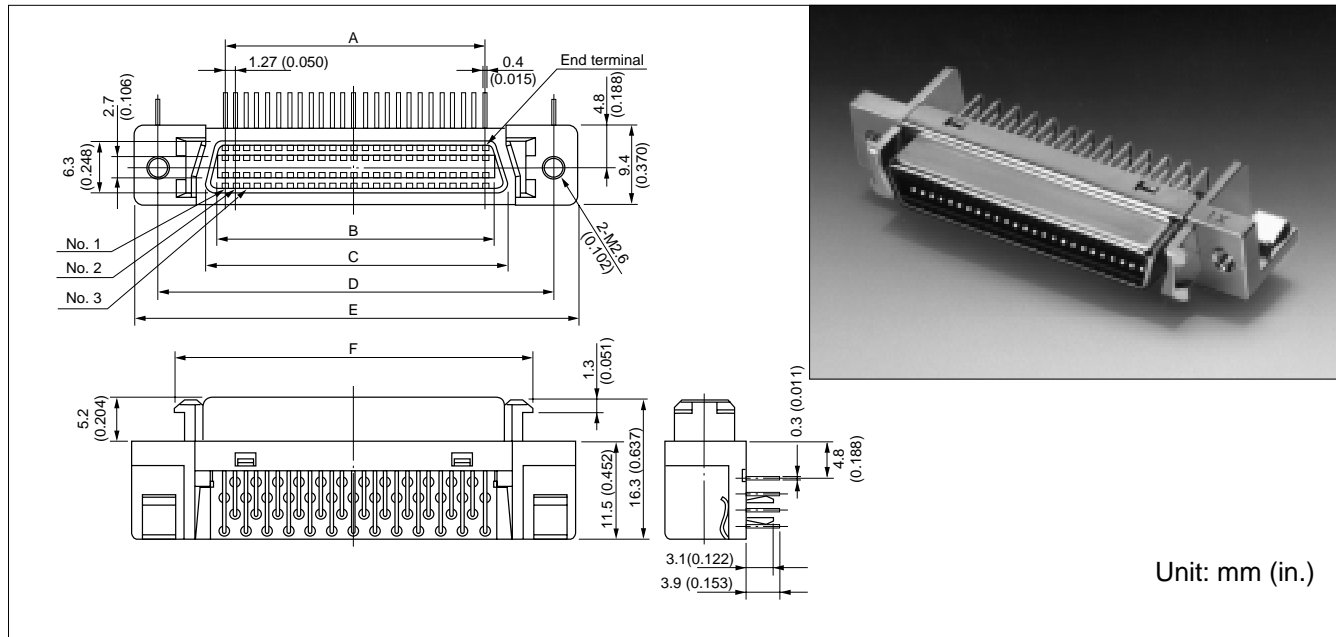

■ MOUNTING HOLE LAYOUT (COMPONENT SIDE)

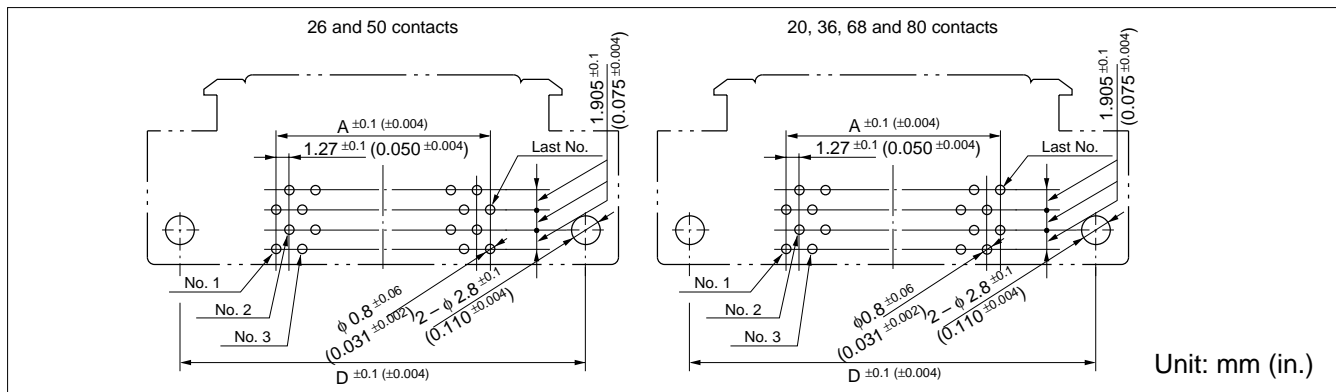

■ PATTERN INHIBITED AREAS

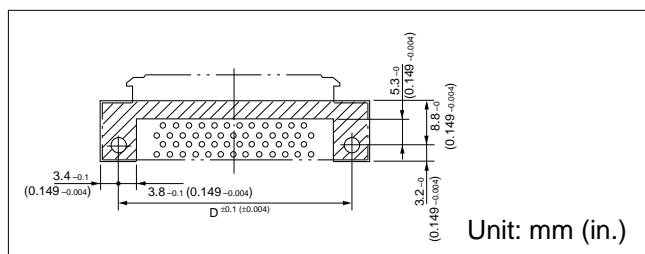

■ RECOMMENDED PANEL DIMENSIONS

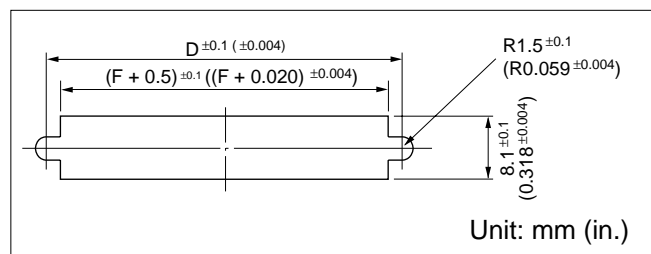

■ PART NUMBERS AND DIMENSIONS

Unit: mm (in.)

Number of contacts	Part number	A	B	C	D	E	F
20	FCN-245D020-G/H	11.43 (0.450)	13.45 (0.529)	16.45 (0.647)	27.45 (1.080)	33.35 (1.312)	23.30 (0.917)
26	FCN-245D026-G/H	15.24 (0.600)	17.26 (0.679)	20.26 (0.797)	31.26 (1.231)	37.16 (1.462)	27.11 (1.067)
36	FCN-245D036-G/H	21.59 (0.850)	23.61 (0.929)	26.61 (1.047)	37.61 (1.480)	43.51 (1.712)	33.46 (1.317)
50	FCN-245D050-G/H	30.48 (1.200)	32.50 (1.279)	35.50 (1.397)	46.50 (1.830)	52.40 (2.062)	42.35 (1.667)
68	FCN-245D068-G/H	41.91 (1.650)	43.93 (1.729)	46.93 (1.847)	57.93 (2.280)	63.83 (2.512)	53.78 (2.117)
80	FCN-245D080-G/H	49.53 (1.950)	51.55 (2.029)	54.55 (2.147)	65.55 (2.580)	71.45 (2.812)	61.40 (2.417)

INSULATION DISPLACEMENT CONNECTION (IDC) PLUG

■ DIMENSIONS

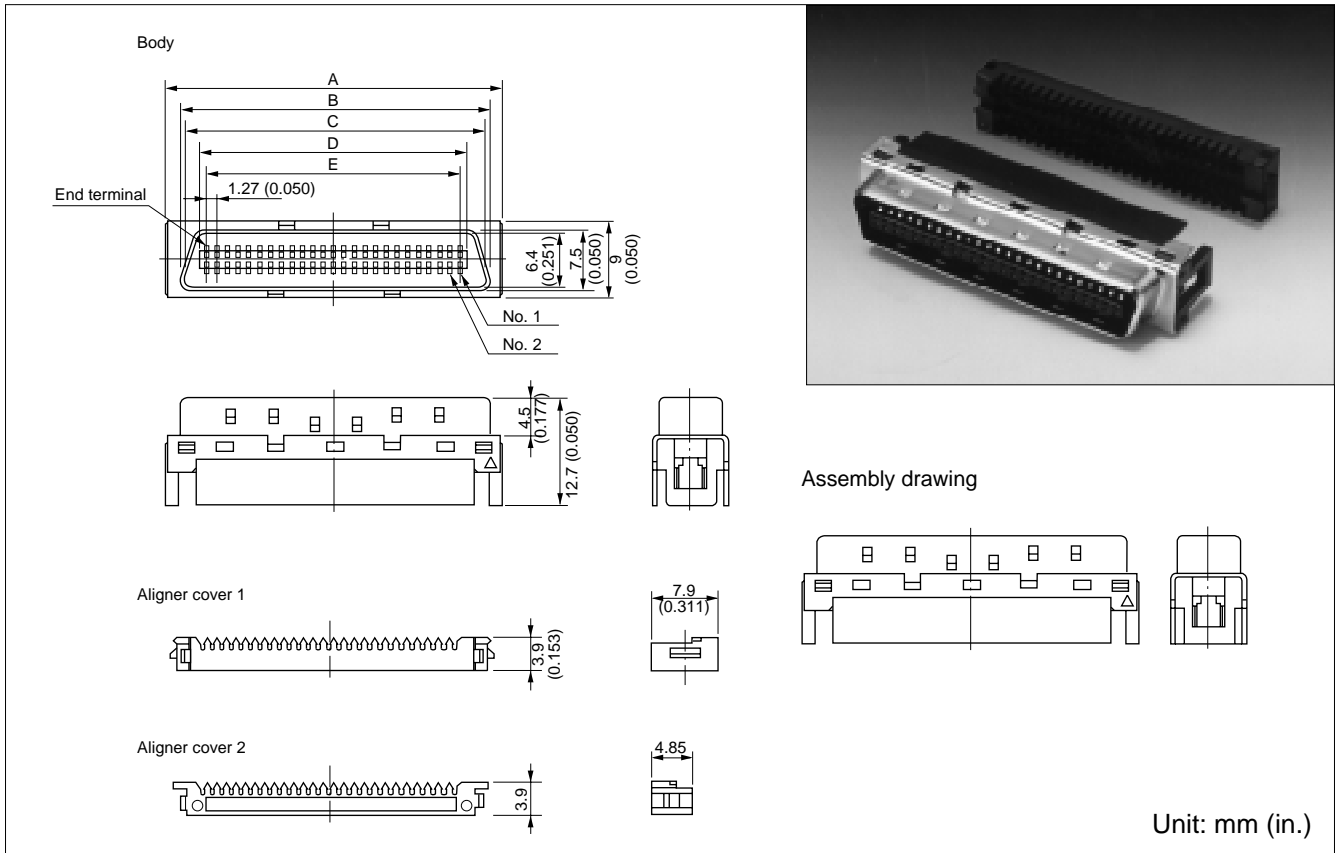

■ PART NUMBERS AND DIMENSIONS

Unit: mm (in.)

Number of contacts	Insulation diameter of applicable wire	Part number	A	B	C	D	E
20	φ0.5 to 0.65 mm	FCN-247R020-G/E	21.24 (0.836)	17.55 (0.690)	16.55 (0.651)	13.25 (0.521)	11.43 (0.450)
26	φ0.5 to 0.65 mm	FCN-247R026-G/E	25.05 (0.986)	21.36 (0.840)	20.36 (0.801)	17.06 (0.671)	15.24 (0.600)
36	φ0.5 to 0.65 mm	FCN-247R036-G/E	31.40 (1.236)	27.71 (1.090)	26.71 (1.051)	23.41 (0.921)	21.59 (0.850)
50	φ0.5 to 0.65 mm	FCN-247R050-G/E	40.29 (1.586)	36.60 (1.440)	35.60 (1.401)	32.30 (1.271)	30.48 (1.200)
68	φ0.5 to 0.65 mm	FCN-247R068-G/E	51.72 (2.036)	48.03 (1.890)	47.03 (1.851)	43.73 (1.721)	41.91 (1.650)
80	φ0.5 to 0.65 mm	FCN-247R080-G/E	59.34 (2.336)	55.65 (2.190)	54.65 (2.151)	51.35 (2.021)	49.53 (1.950)

50-contact connectors for IDC of wires with φ0.8 mm (0.031 in.) to φ0.88 mm (0.035 in.) insulation diameter are also available. Specify a part number by replacing -G/E at the end with -G/F.

RIGHT-ANGLE SOCKET [LIGHTWEIGHT TYPE]

■ DIMENSIONS

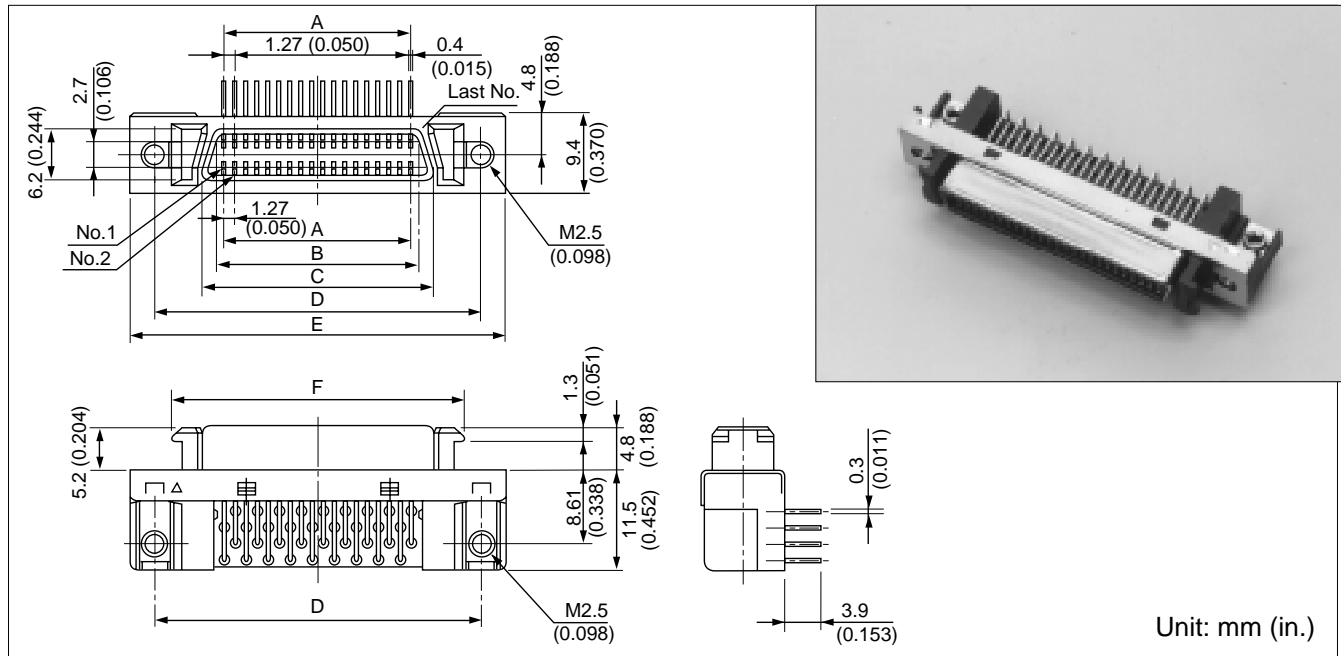

■ MOUNTING HOLE LAYOUT (COMPONENT SIDE)

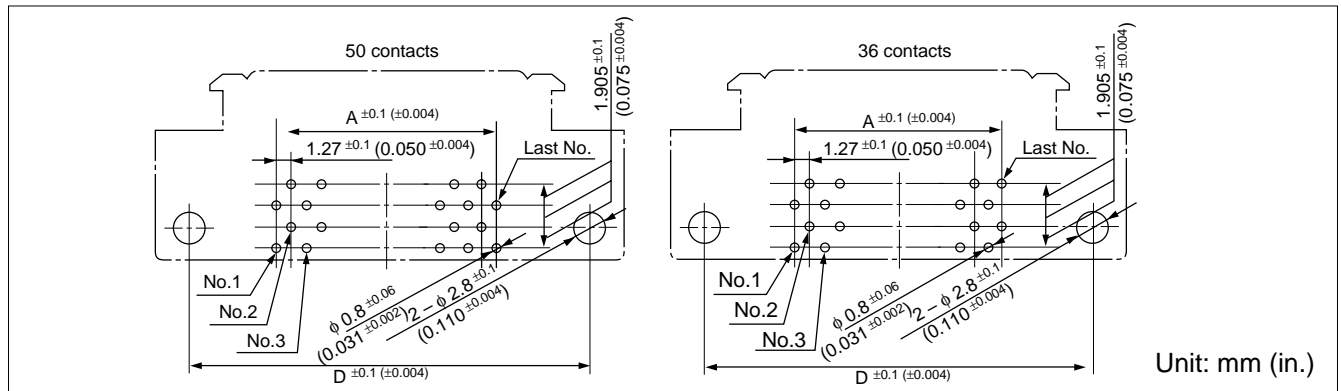

■ PATTERN INHIBITED AREAS

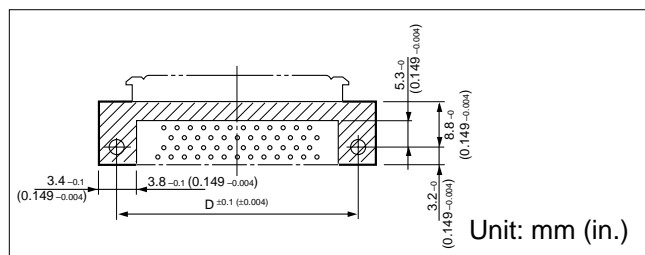

■ RECOMMENDED PANEL DIMENSIONS

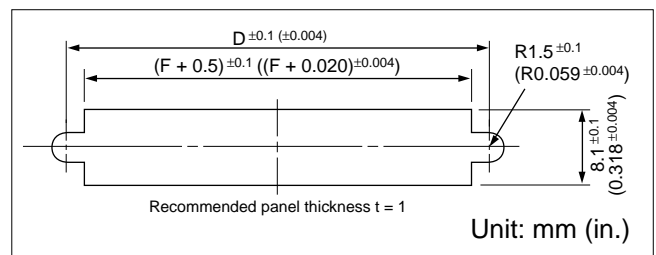

■ PART NUMBERS AND DIMENSIONS

Unit: mm (in.)

Number of contacts	Part number	A	B	C	D	E	F
36	FCN-245D036-L/L	21.59 (0.850)	23.61 (0.929)	26.61 (1.047)	37.61 (1.480)	43.51 (1.712)	33.46 (1.317)
50	FCN-245D050-L/L	30.48 (1.200)	32.50 (1.279)	35.50 (1.397)	46.50 (1.830)	52.40 (2.062)	42.35 (1.667)

* This socket is 40% lighter than a socket with die cast shell.

EMI/ESD RESISTANT COVER

■ DIMENSIONS

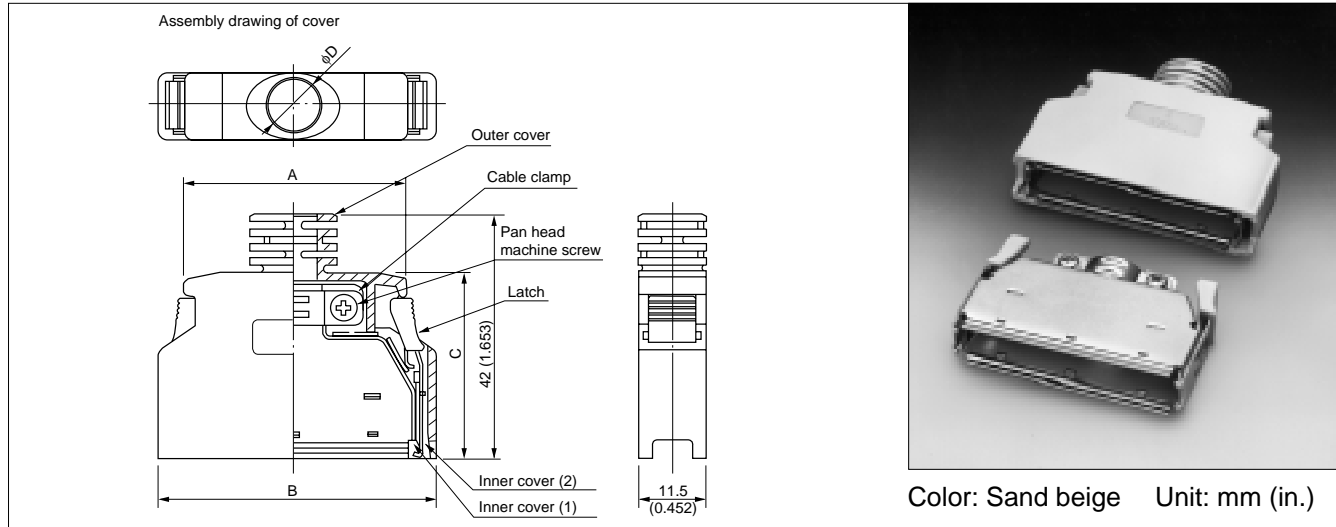

■ PART NUMBERS AND DIMENSIONS

Unit: mm (in.)

Number of contacts	Part number	A	B	C	D
20	FCN-240C020-A/S	19.95 (0.785)	29.65 (1.167)	34.50 (1.358)	6.8 (0.268)
26	FCN-240C026-A/S	23.76 (0.935)	33.46 (1.317)	38.31 (1.508)	7.1 (0.280)
36	FCN-240C036-A/S	30.11 (1.185)	39.81 (1.507)	32.00 (1.259)	8.2 (0.323)
50	FCN-240C050-A/S	39.00 (1.535)	48.70 (1.917)	32.00 (1.259)	9.0 (0.354)
	FCN-240C050-E/S				9.8 (0.386)
68	FCN-240C068-A/S	50.43 (1.985)	60.13 (2.367)	32.00 (1.259)	9.1 (0.358)
80	FCN-240C080-A/S	58.05 (2.285)	67.75 (2.667)	32.00 (1.259)	9.7 (0.382)

*: The standard color of the EMI/ESD resistant covers is sand beige, but black, ivory, and art gray are also available. Specify a part number as follows:

Black: FCN-240C□□□-Δ/S-K0. Ivory: FCN-240C□□□-Δ/S-C0. Art gray: FCN-240C□□□-Δ/S-A0.

□□□: Number of contacts. Δ: Cover type.

WIDE-HOLE COVER FOR SCSI CABLES

■ DIMENSIONS

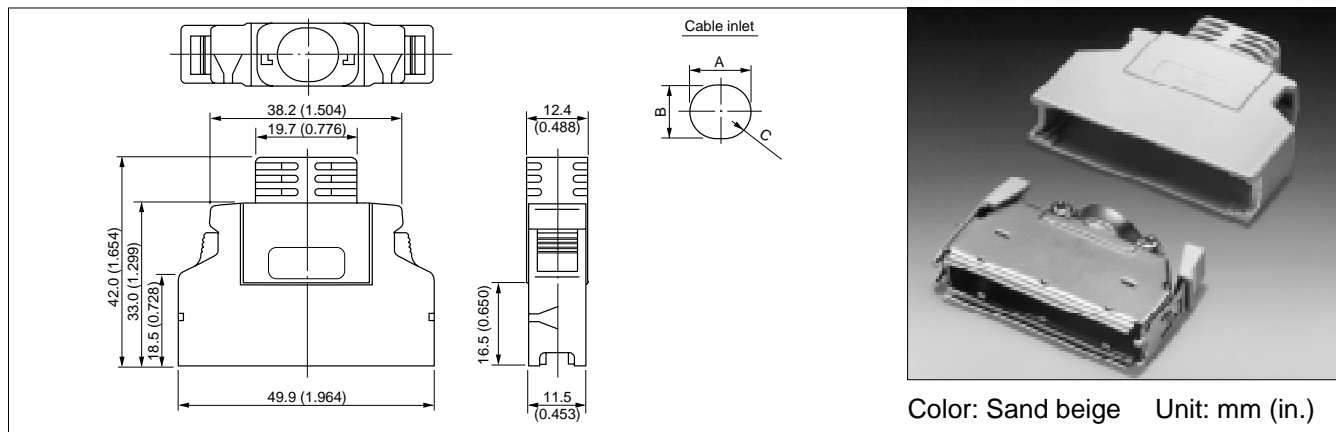

■ PART NUMBERS AND DIMENSIONS

Part number	Cable inlet	
	A × B	C
FCN-240C050-B/S	12.45 × 11.00	R5.5
FCN-240C050-D/S	11.05 × 9.40	R4.7

*: The standard color of the EMI/ESD resistant covers is sand beige, but black, ivory, and art gray are also available. Specify a part number as follows:

Black: FCN-240C□□□-Δ/S-K0. Ivory: FCN-240C□□□-Δ/S-C0.

Art gray: FCN-240C□□□-Δ/S-A0.

□□□: Number of contacts. Δ: Cover type.

240R Series

EMI/ESD RESISTANT COVER, LATCH-ON-HOOD TYPE

■ DIMENSIONS

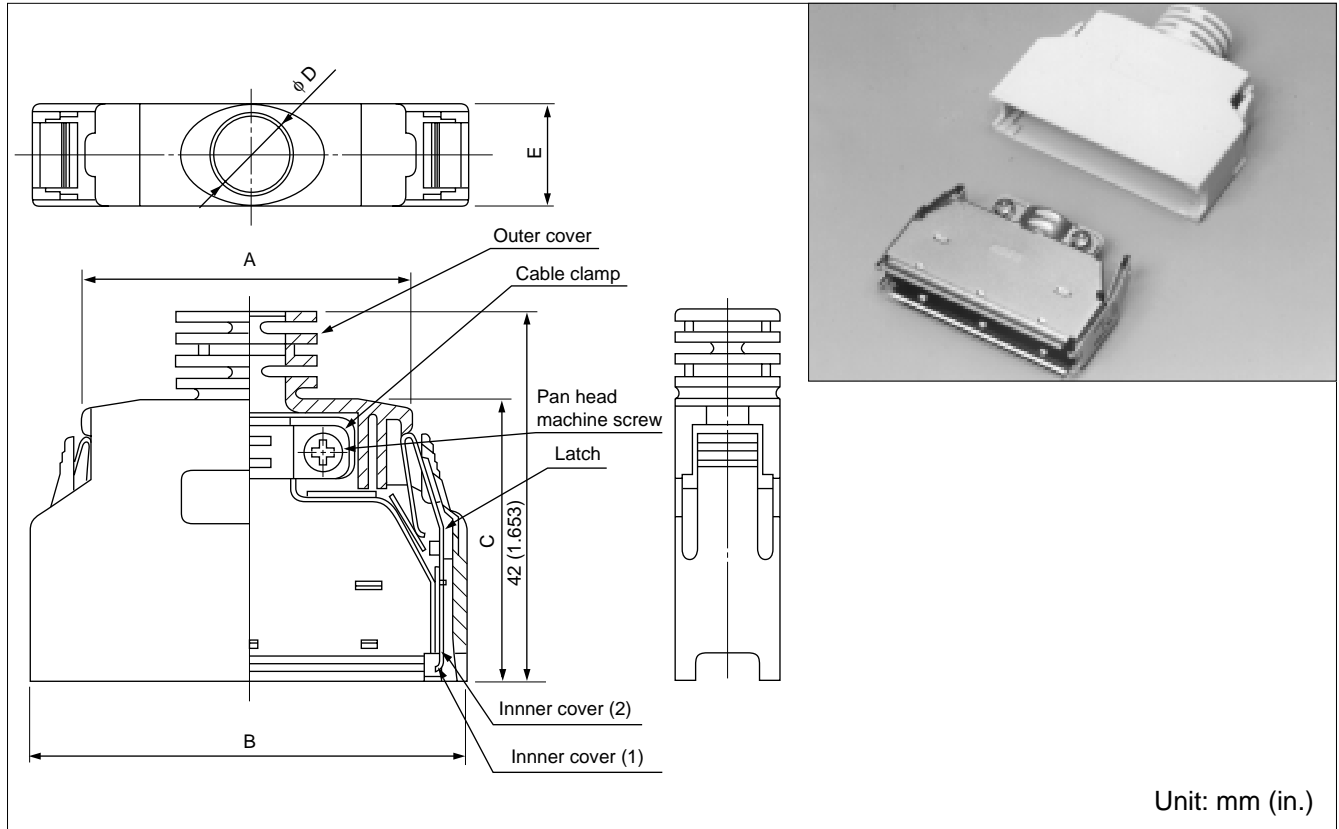

■ PART NUMBERS AND DIMENSIONS

Unit: mm (in.)

Number of contacts	Part number	A	B	C	D	E
36	FCN-240C036-A/SC	29.11 (1.146)	39.81 (1.567)	32.00 (1.259)	8.2 (0.223)	11.5 (0.223)
50	FCN-240C050-A/SC	38.00 (1.496)	48.70 (1.917)	32.00 (1.259)	9.0 (0.223)	11.5 (0.223)
	FCN-240C050-E/SC				9.8 (0.223)	11.4 (0.223)

ACCESSORY (DUST CAP FOR SOCKET) (230R SERIES AND 240R SERIES)

Used to prevent dust from entering the contact section of a plug connector.

■ DIMENSIONS

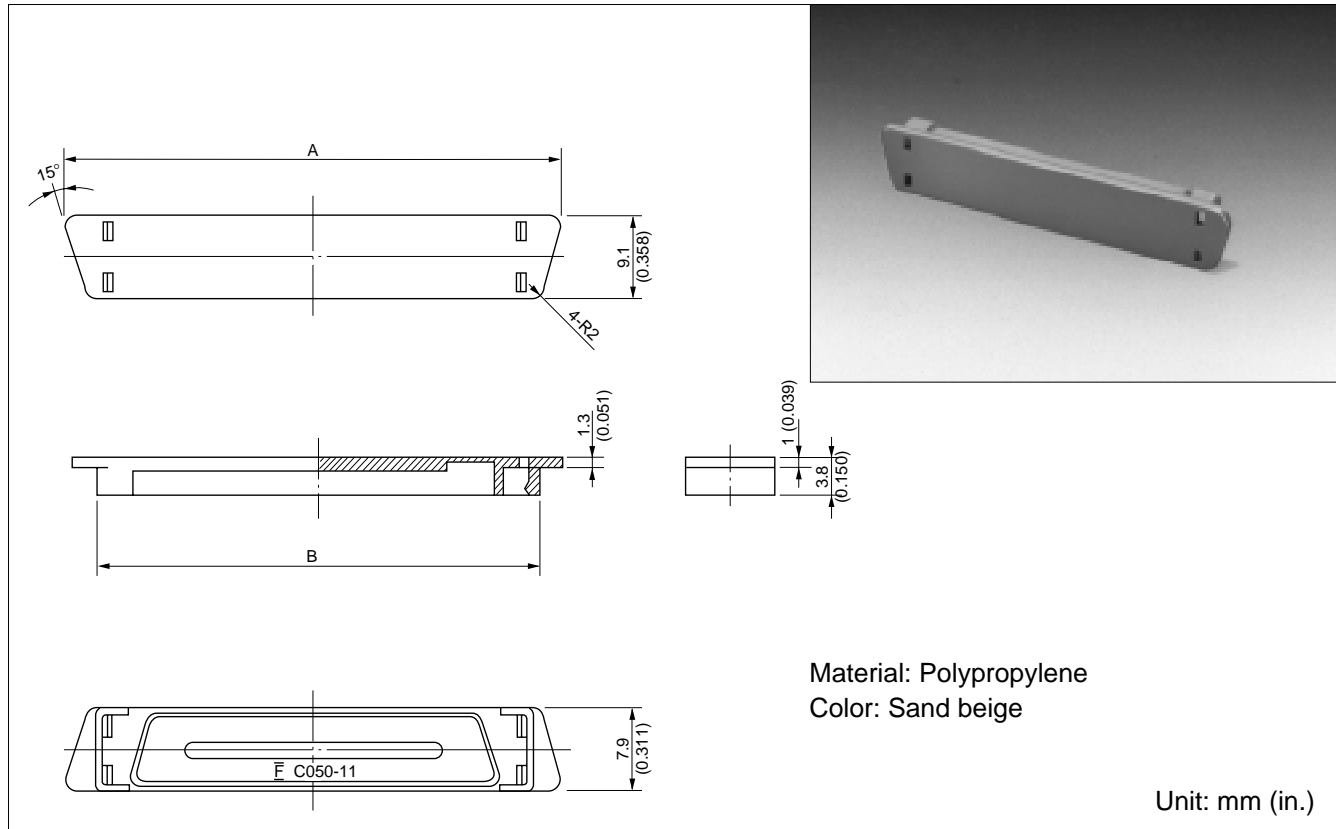

■ PART NUMBERS AND DIMENSIONS

Unit: mm (in.)

Number of contacts	Part number	A	B
28	FCN-230C028-11	35.7 (1.406)	30.1 (1.185)
36	FCN-230C036-11	40.8 (1.606)	35.2 (1.386)
50	FCN-230C050-11	49.7 (1.957)	44.1 (1.736)
68	FCN-230C068-11	61.1 (2.406)	55.5 (2.185)

■ APPLICATIONS

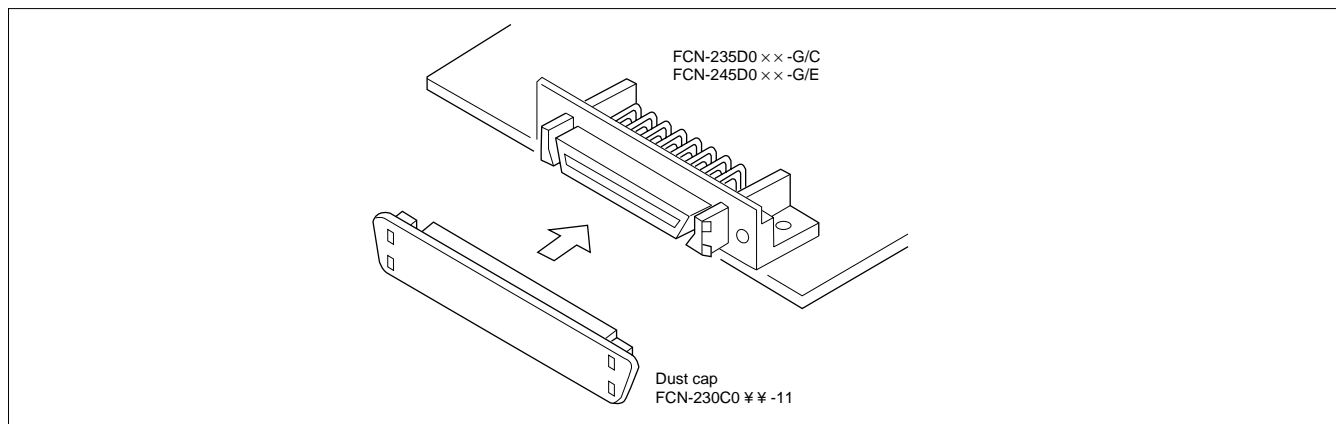

CABLE ASSEMBLY TOOLS

The following tools are needed to assemble FCN-230/230R/240/240R series connectors.

- Cable aligner (semiautomatic cable aligner or hand tool)
- IDC tool

1. Cable Aligner

Item	Semiautomatic cable aligner			Hand tool
	Body/Controller	Bed	Adaptor	
FCN-237J	FCN-M561-A/C	FCN-P560-2/A	FCN-K560-A-xxx	FCN-237T-T062/H
FCN-237R			FCN-K560-R-xxx	
FCN-247J			FCN-K560-K-xxx	
FCN-247R		FCN-P560-2/J	FCN-K560-J-xxx	FCN-247T-T061/H

xxx indicates the number of contacts.

2. Insulation Displacement Connection (IDC) tool

Item	Hand press	Head/Table
FCN-237J	FCN-237T-T109/H	FCN-237T-T064/H
FCN-237R		FCN-237T-T067/H
FCN-237D		FCN-237T-T075/H
FCN-247J		FCN-247T-T066/H
FCN-247R		FCN-247T-T068/H
FCN-247D		FCN-247T-T077/H

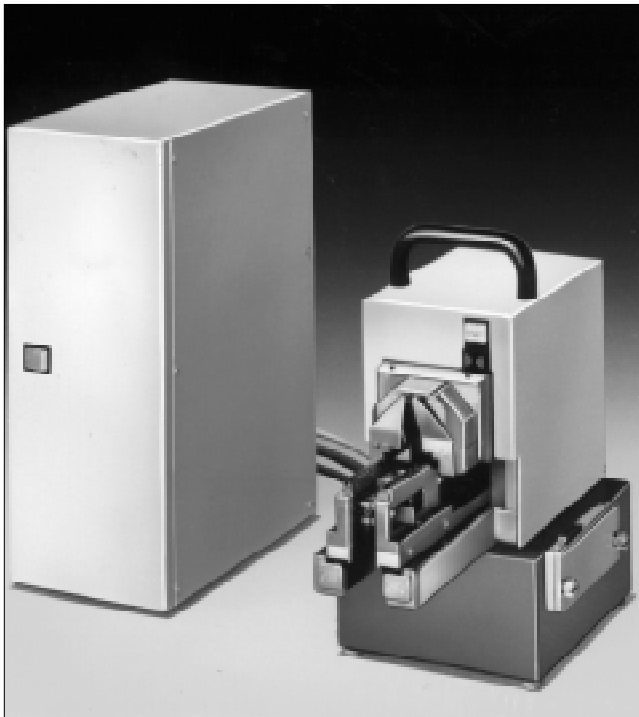

• Cable aligner

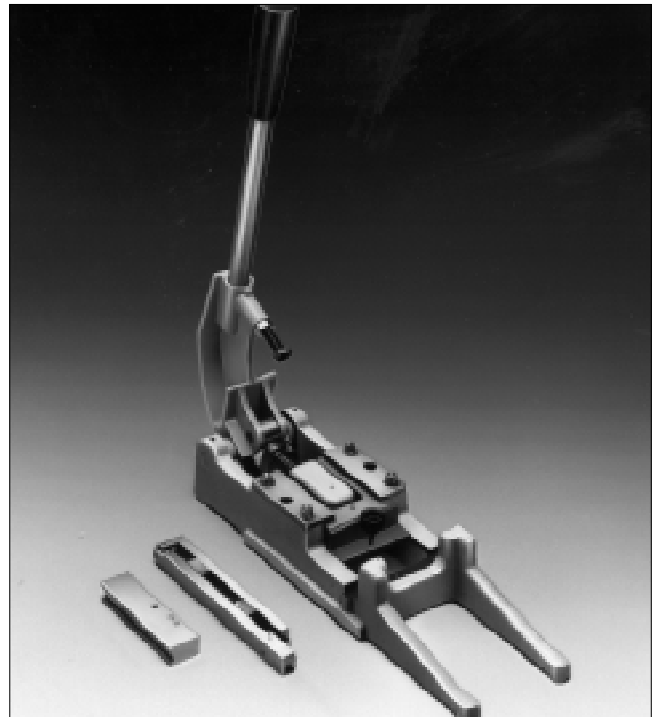

• Insulation displacement connection (IDC) tool

240R Series

**Semi-Automatic Tools
Cable Aligning Machine
Main Body (FCN-M551-120, FCN-M551-220)**

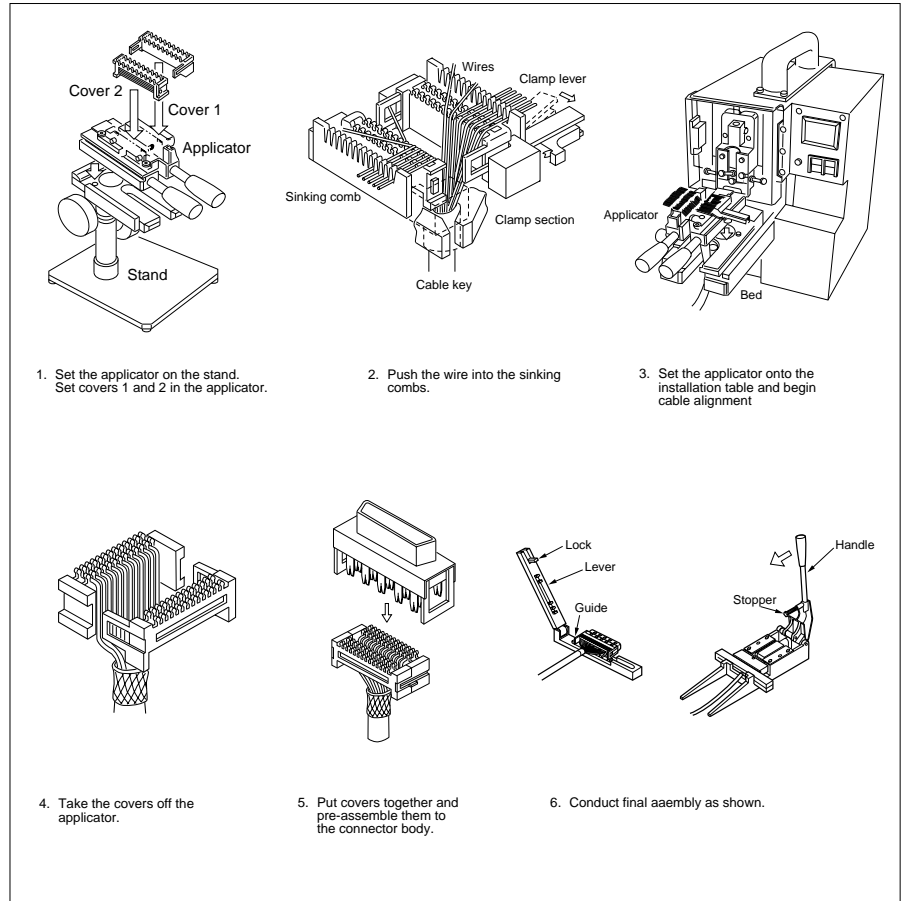

Head (FCN-H550-1/A)



Stand (FCN-D550)



Applicator (FCN-A550-1/A-xxx)



IDC Tool (FCN-237T-T109/H,
FCN-237T-T067/H locator)

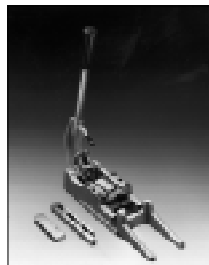

FCN-240R SERIES IDC ROUND-CABLE CONNECTORS

SOCKET: FCN-247R***-G/E (***: 020, 026, 036, 050, 068, 080)

Pos No.	Applied Wire (wire Dia.: mm)	Connector Part number	Cable Aligner		IDC Tool
			Hand Tool	Semi-Auto	
20 68	#28 to #30 (0.5 to 0.65)	FCN-247R020-G/E FCN-247R080-G/E	FCN-247T-T061/H	(See below*)	HAND PRESS: FCN-237T-T109/H HEAD & Locator: FCN-237T-T067/H

Semi-automatic-Medium Level
 Body: :FCN-M551-120
 Head Assembly: :FCN-H550
 Applicator: :FCN-A550-1/J-***(***: 020, 028, 036, 050, 068, 080)
 Stand: :FCN-D550

Fujitsu Components International Headquarter Offices

Japan

Fujitsu Component Limited
Gotanda-Chuo Building
3-5, Higashigotanda 2-chome, Shinagawa-ku
Tokyo 141-0022, Japan
Tel: (81-3) 5449-7010
Fax: (81-3) 5449-2626
Email: promothq@fcl.fujitsu.com
Web: www.fcl.fujitsu.com

North and South America

Fujitsu Components America, Inc.
250 E. Caribbean Drive
Sunnyvale, CA 94089 U.S.A.
Tel: (1-408) 745-4900
Fax: (1-408) 745-4970
Email: components@us.fujitsu.com
Web: <http://us.fujitsu.com/components>

Europe

Fujitsu Components Europe B.V.
Diamantlaan 25
2132 WV Hoofddorp
Netherlands
Tel: (31-23) 5560910
Fax: (31-23) 5560950
Email: info@fceu.fujitsu.com
Web: emea.fujitsu.com/components

Asia Pacific

Fujitsu Components Asia Ltd.
102E Pasir Panjang Road
#01-01 Citilink Warehouse Complex
Singapore 118529
Tel: (65) 6375-8560
Fax: (65) 6273-3021
Email: fcal@fcal.fujitsu.com
www.fcal.fujitsu.com

© 2007 Fujitsu Components America, Inc. All rights reserved. All trademarks or registered trademarks are the property of their respective owners. Fujitsu Components America, Inc. or its affiliates do not warrant that the content of the datasheet is error free. In a continuing effort to improve our products, Fujitsu Components America, Inc. or its affiliates reserve the right to change specifications/datasheets without prior notice. Rev. November 2, 2007.