

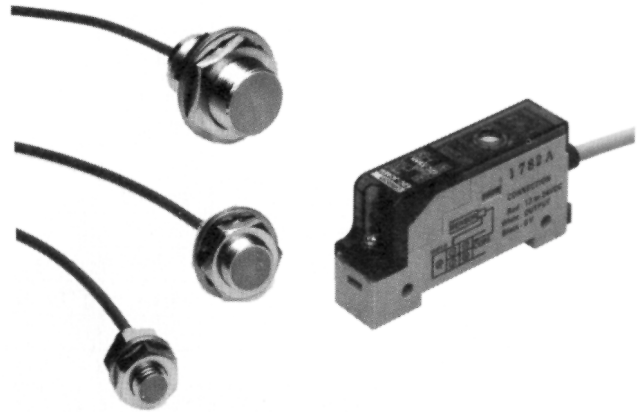

Proximity Sensor with Separate Amp
Resists Ambient Temperatures up to
200°C (392°F)

- A wide operating temperature range of -10° to 200°C (14° to 392°F)
- Ideal for checking the closing of mold halves on injection molding machines or for position sensing in high temperature chambers or ovens
- The compact, 14-mm wide amplifier can be mounted to DIN track in normal temperature environments
- Adjustable sensing distance (remote)
- Normally open/normally closed operation switch-selectable



Ordering Information

Sensing head		Sensing distance	Sensor part number	Amplifier part number
M8	Shielded 	1.5 mm	E2C-X1R5AH	E2C-JC4CH
M12		2 mm	E2C-X2AH	E2C-JC4DH
M18		5 mm	E2C-X5AH	E2C-JC4EH

Note: Sensors with 5 m cables are available on special request.

Application Example

■ DETECTING POSITION OF MOLD HALVES

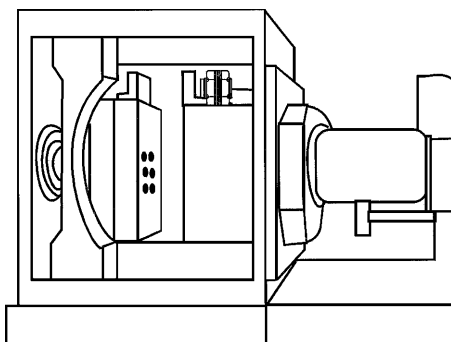

Specifications

■ SENSOR

Part number		E2C-X1R5AH	E2C-X2AH	E2C-X5AH
Sensor type		Inductive		
Body	Size	M8	M12	M18
	Type	Shielded		
Required amplifier		E2C-JC4CH	E2C-JC4DH	E2C-JC4EH
Detectable object type		Metallic Objects		
Usable setting distance		0 to 1.5 mm (0 to 0.06 in)	0 to 2 mm (0 to 0.08 in)	0 to 5 mm (0 to 0.20 in)
Standard target size (mild steel, L x W x H)		8 x 8 x 1 mm (0.32 x 0.32 x 0.04 in)	12 x 12 x 1 mm (0.47 x 0.47 x 0.04 in)	18 x 18 x 1 mm (0.71 x 0.71 x 0.04 in)
Differential travel		0.04 mm (0.002 in) max.		0.1 mm (0.004 in) max.
Response frequency		300 Hz		
Materials	Housing	Brass		
	Sensing face	Polyether ketonic resin		
	Cable sheath	Teflon® resin		
Connections	Prewired	3 m (9.8 ft) coaxial cable		
Weight with cable		Approx. 50 g (1.8 oz)	Approx. 60 g (2.1 oz)	Approx. 140 g (4.9 oz)
Enclosure rating	UL	—		
	NEMA	—		
	IEC 144	IP60		
Approvals	UL	—		
	CSA	—		
Ambient operating temperature		-10°C to 200°C (14°F to 392°F)		
Vibration		10 to 55 Hz, 1.5 mm (0.06 in) double amplitude for 2 hours each in X, Y, and Z directions		
Shock	Malfunction	50 G		

■ AMPLIFIERS

Part number		E2C-JC4CH	E2C-JC4DH	E2C-JC4EH
Supply voltage		10 to 30 VDC		
Current consumption		45 mA max.		
Sensing distance adjustable range		Adjustable with 4-turn potentiometer between 20% and 100% of the rated sensing distance		
Control output		NPN open collector, 100 mA max. load		
Cord length compensation		3 or 5 m selectable		
Indicators		Operation indicator (red LED)		
Materials	Case	PVC plastic		
Mounting		DIN rail track		
Connections		Pre-wired, 3-conductor cable, 2 m length		
Weight		80 g (3 oz)		
Enclosure ratings	UL	—		
	NEMA	—		
	IEC 144	IP20		
Approvals	UL	—		
	CSA	—		
Ambient operating temperature		-10°C to 55°C (14°F to 131°F)		
Vibration		10 to 55 Hz, 1.5 mm double amplitude for 2 hours each in X, Y, Z directions		
Shock		10 G		

Operation

■ AMPLIFIER SWITCH SETTINGS

Operation Mode

NC Output transistor is ON when the sensor detects a sensing object.
 NO

NC Output transistor is OFF when the sensor detects a sensing object.
 NO

Cord Length Compensation

3 m Set to 3 m when the length of the sensor cable is 3 m long.
 5 m

3 m Set to 5 m when the length of the sensor cable is 5 m long.
 5 m

■ OUTPUT CIRCUIT DIAGRAM

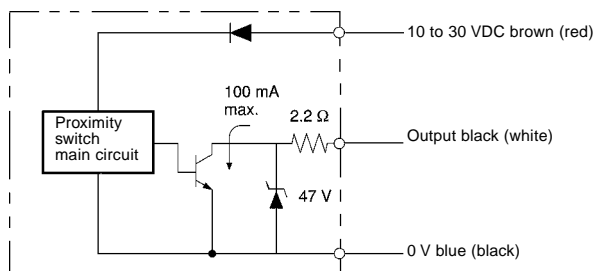

■ TIMING CHART

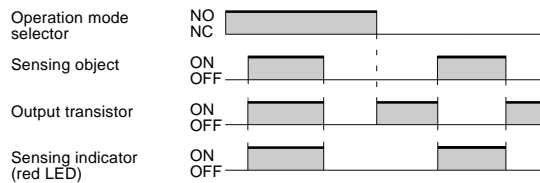

■ CONNECTION

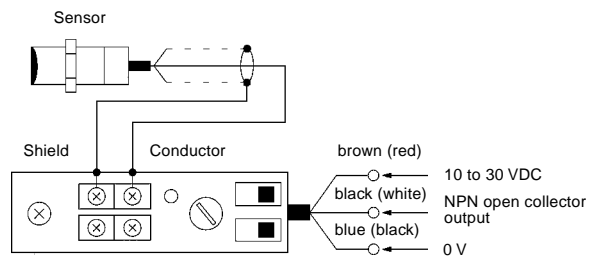

Note: JIS colors are shown in parentheses.

Engineering Data

■ OPERATING RANGE (TYPICAL)

E2C-X1R5AH + E2C-JC4CH

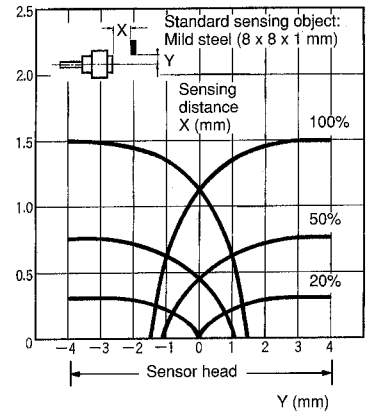

E2C-X2AH + E2C-JC4DH

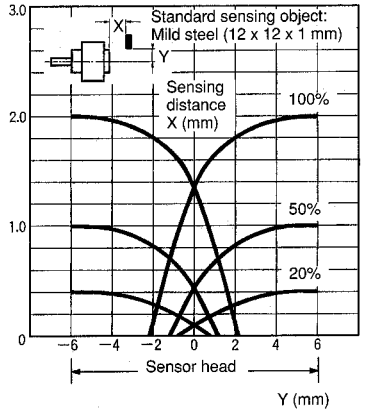

E2C-X5AH + E2C-JC4EH

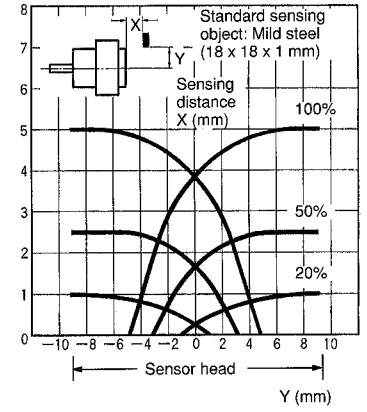

■ SENSING DISTANCE VS. SENSING OBJECT (TYPICAL)

E2C-X1R5AH + E2C-JC4CH

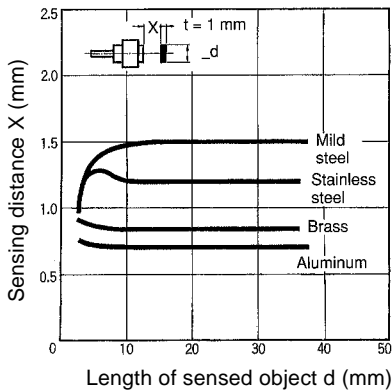

E2C-X2AH + E2C-JC4DH

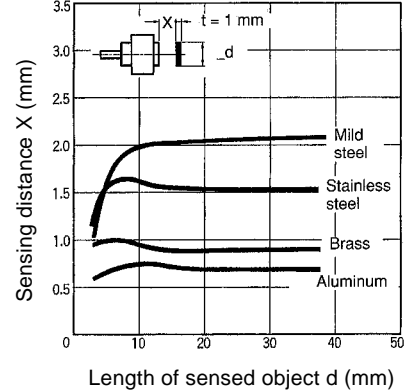

E2C-X5AH + E2C-JC4EH

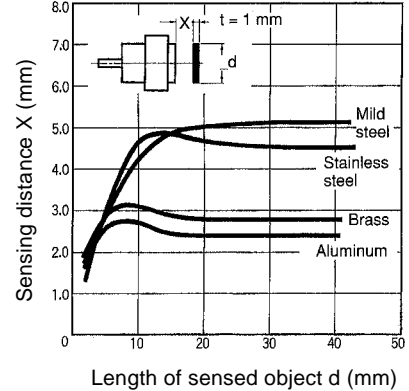

Nomenclature

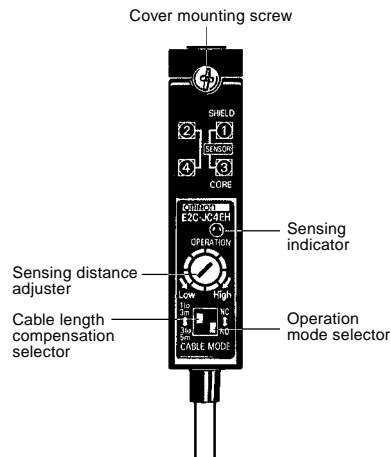

Dimensions

Unit: mm (inch)

E2C-X1R5AH

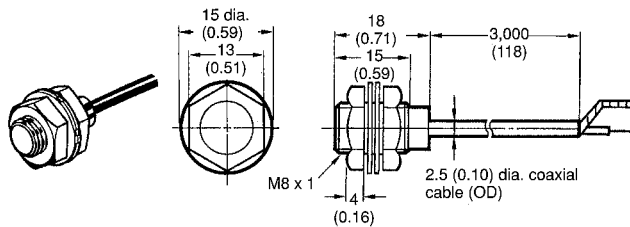

E2C-X2AH

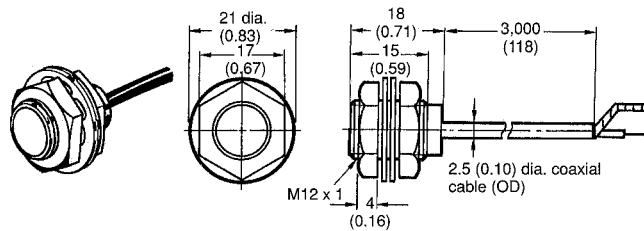

E2C-X5AH

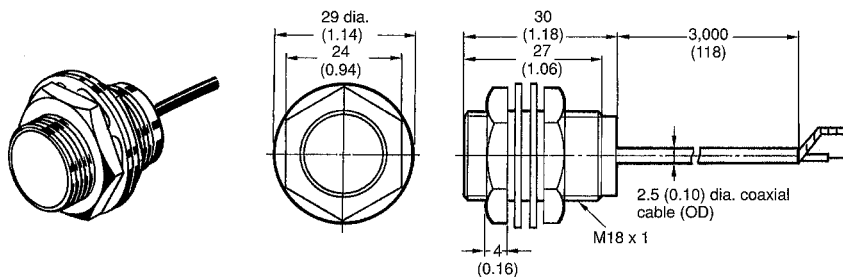

E2C-JC4_H

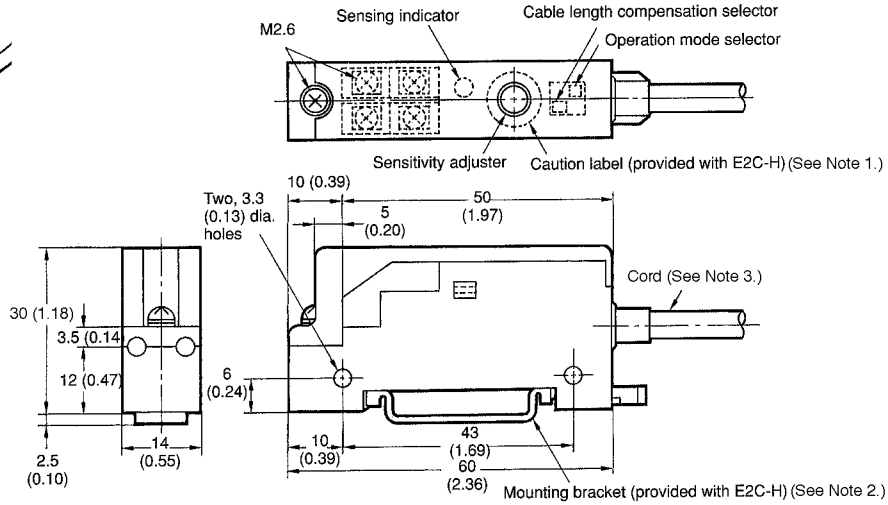
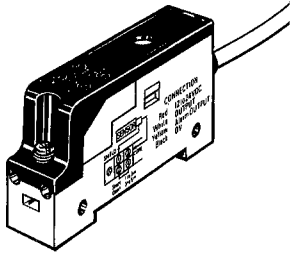

- Note:
1. Use the caution label to prevent improper operation after sensitivity adjustment.
 2. The mounting bracket is not required when DIN-track mounting.
 3. Cord: 4.5 dia. (OD), 4-conductor, vinyl-insulated round cord, standard length: 2 m (6.45 ft) (It is possible to extend the cord up to 200 m using an independent metal conduit).

Amplifier Mounting Bracket (supplied with each unit)

Unit: mm (inch)

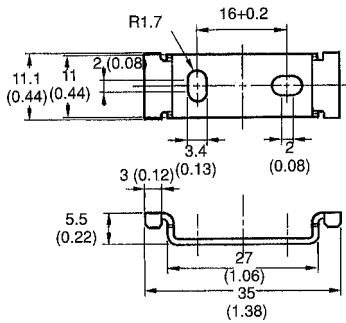

Installation

Do not tighten the nut with excessive force. A washer must be used with the nut.

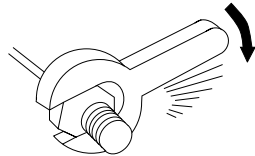

Model	Torque
E2C-X1R5AH	20 kgf • cm (17.3 in-lbs)
E2C-X2AH	60 kgf • cm (52 in-lbs)
E2C-X5AH	150 kgf • cm (130 in-lbs)

Note: The above torque values apply when you use a toothed washer with the nut that you tighten.

Effects of Surrounding Metal

When mounting the E2C-H within a metal panel, ensure that the clearances given in the following table are maintained. Failure to maintain these distances may cause deterioration in the performance of the sensor.

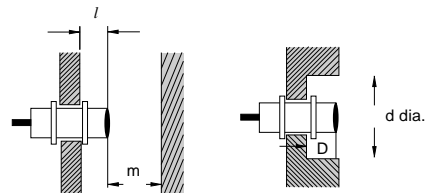

Model	l	d	D	m
E2C-X1R5AH	0 mm (0.0 in)	8 mm (0.31 in)	0 mm (0.0 in)	4.5 mm (0.18 in)
E2C-X2AH	0 mm (0.0 in)	12 mm (0.47 in)	0 mm (0.0 in)	6 mm (0.24 in)
E2C-X5AH	0 mm (0.0 in)	18 mm (0.71 in)	0 mm (0.0 in)	15 mm (0.59 in)

Mutual Interference

When installing two or more E2C-H sensors face to face or side by side, ensure the minimum distances given in the following table are maintained.

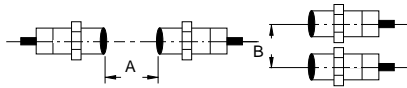

Model	A	B
E2C-X1R5AH	20 mm (0.79 in)	15 mm (0.59 in)
E2C-X2AH	30 mm (1.18 in)	20 mm (0.79 in)
E2C-X5AH	50 mm (1.97 in)	35 mm (1.38 in)

Mounting

Mount the front panel to a DIN track or mounting bracket first, and then mount the rear part. The mounting bracket is provided with the E2C-H.

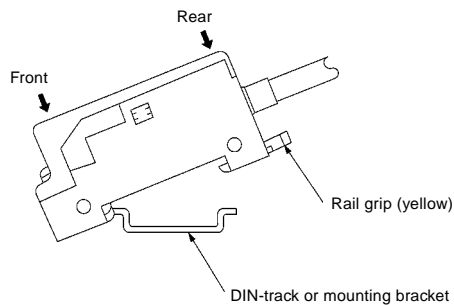

Removal

You can remove the E2C-H by pulling the yellow grip rail on the lower part of the rear panel with a flat-blade screwdriver.

Miscellaneous

Do not expose the sensor to steam or install it in places where water may be sprayed because the sensor is not water resistive.

Do not cut or extend the sensor cord or the sensor will not maintain its characteristics.

After you adjust the sensing distance, apply the caution label (provided with the E2C-H) to the amplifier and cover the surface of the sensitivity adjuster hole.

NOTE: DIMENSIONS ARE SHOWN IN MILLIMETERS. To convert millimeters to inches divide by 25.4.

OMRON

OMRON ELECTRONICS, INC.

One East Commerce Drive

Schaumburg, IL 60173

1-800-55-OMRON

OMRON CANADA, INC.

885 Milner Avenue

Scarborough, Ontario M1B 5V8

416-286-6465