

## ASMT-Mxx9

### Moonstone® 1W Power LED Light Source



## Data Sheet



### Description

The Moonstone® 1W Power LED Light Source is a high performance energy efficient device which can handle high thermal and high driving current. The exposed pad design has excellent heat transfer from the package to the motherboard.

It is available in various color temperatures ranging from 2600K to 10000K.

The package is compatible with reflow soldering. To facilitate easy pick and place assembly, the LEDs are also available in EIA-compliant tape and reel.

The 1W Power LED light source can be mounted onto metal core PCB enabling optimum heat dissipation and ease of installation.

### Features

- Available in Cool White & Warm White color
- Energy efficient
- Exposed pad for excellent heat transfer
- Suitable for reflow soldering process
- High current operation
- Long operation life
- Wide viewing angle
- Silicone encapsulation
- Non-ESD sensitive (threshold >16kV)
- MSL 4 products

### Applications

- Portable (flash light, bicycle head light)
- Reading light
- Architectural lighting
- Garden lighting
- Decorative lighting

### Package Dimension for Moonstone®

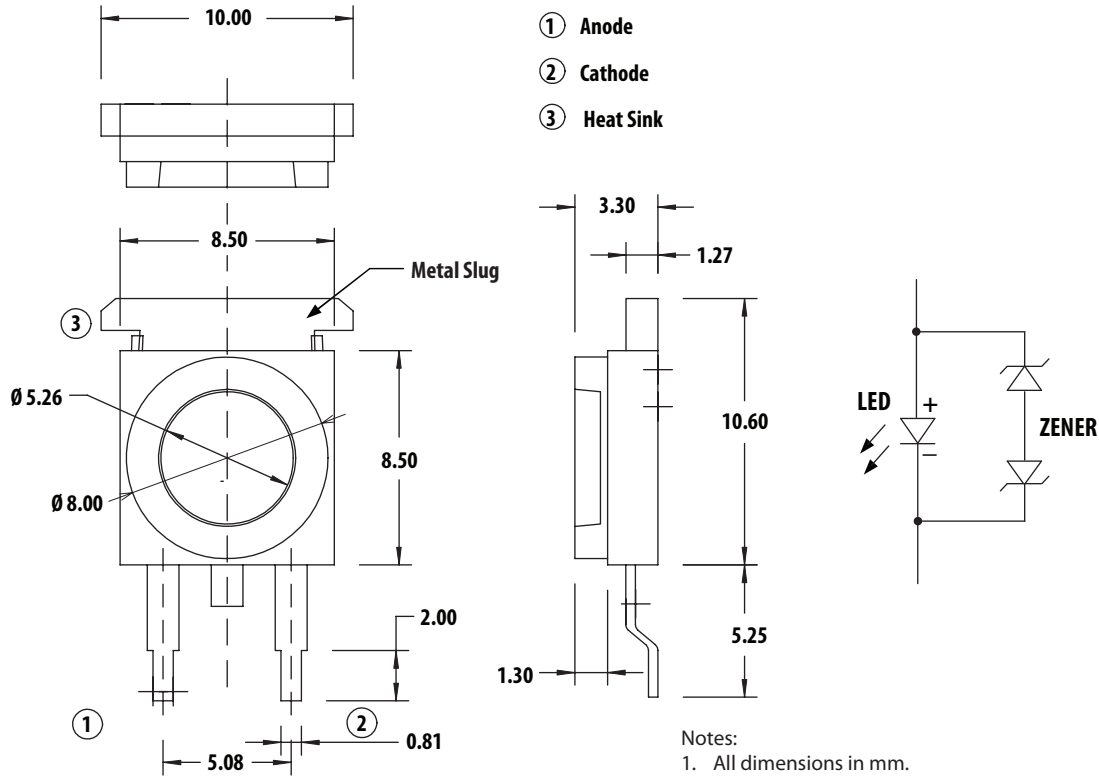

Figure 1. Moonstone® package outline drawing.

### Package Dimension for Moonstone® on MCPCB

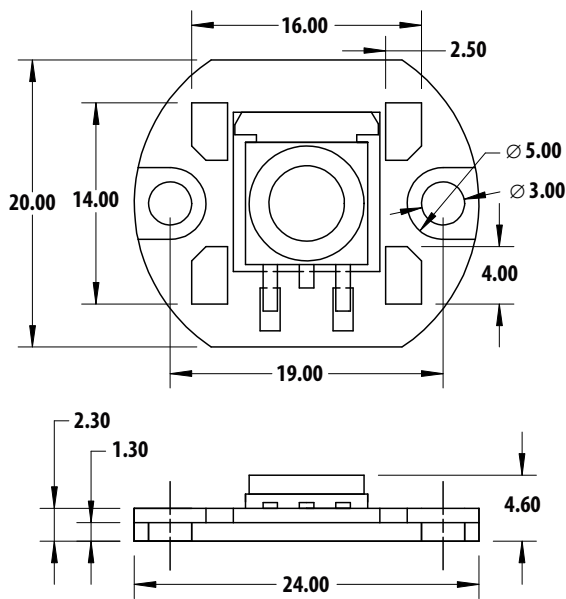

Figure 2. MCPCB I package outline drawing.

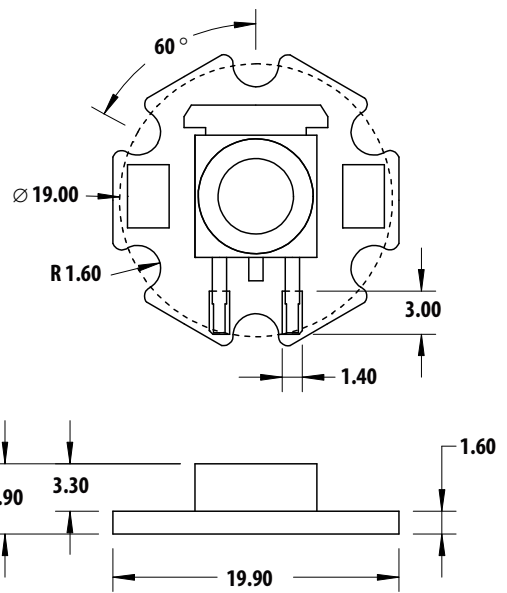
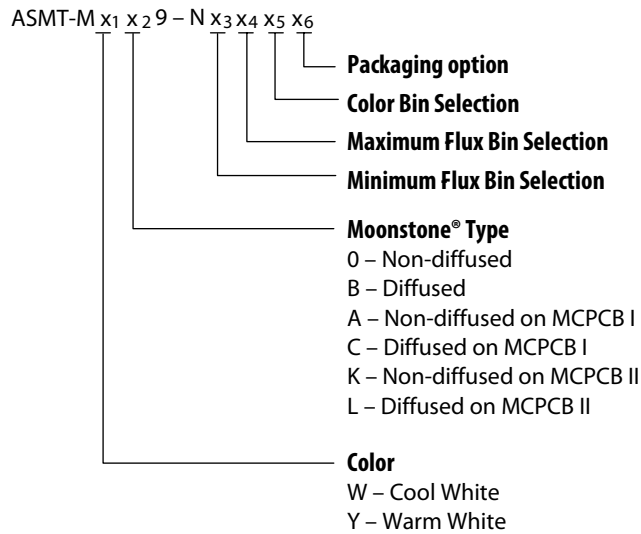

Figure 3. MCPCB II package outline drawing.

Notes:

1. All dimensions in millimeters.
2. Tolerance is  $\pm 0.1$  mm unless otherwise specified.

## Part Numbering System



Note:

1. Please refer to Page 7 for selection details.

## Device Selection Guide (T<sub>J</sub> = 25°C)

Part Number	Color	Luminous Flux, $\Phi_V^{[1,2]}$ (lm)			Test Current (mA)	Dice Technology
		Min.	Typ.	Max.		
ASMT-MWx <sub>2</sub> 9-NLLxx	Cool White	73	80	95	350	InGaN
ASMT-MWx <sub>2</sub> 9-NMMxx		95	-	124		
ASMT-MYx <sub>2</sub> 9-NKLxx	Warm White	56	73	95	350	InGaN
ASMT-MYx <sub>2</sub> 9-NLMxx		73	-	124		
ASMT-MWx <sub>2</sub> 9-NKLxx	Cool White Diffused	56	73	95	350	InGaN
ASMT-MWx <sub>2</sub> 9-NLMxx		73	-	124		
ASMT-MYx <sub>2</sub> 9-NKLxx	Warm White Diffused	56	68	95	350	InGaN
ASMT-MYx <sub>2</sub> 9-NLMxx		73	-	124		

Notes:

1.  $\Phi_V$  is the total luminous flux output as measured with an integrating sphere at 25ms mono pulse condition.
2. Flux tolerance is  $\pm 10\%$
3. For x<sub>2</sub>, please refer to part numbering system.

## Absolute Maximum Ratings

Parameter	ASMT-Mxx9	Unit
DC Forward Current <sup>[1]</sup>	500	mA
Peak Pulsing Current <sup>[2]</sup>	1000	mA
Power Dissipation	2100	mW
Reverse Voltage	5	V
LED Junction Temperature	125	°C
Operating Ambient Temperature Range	-40 to +85	°C
Storage Temperature Range	-40 to +120	°C
Soldering Temperature	Refer to figure 14	

Note:

1. Derate linearly based on Figure 8 and 9.
2. Pulse condition: duty factor = 10%, Frequency = 1kHz.

## Optical Characteristics at 350 mA (T<sub>J</sub> = 25°C)

Part Number	Color	Correlated Color Temperature, CCT (Kelvin)		Viewing Angle 2θ <sub>½</sub> <sup>[1]</sup> (Degrees)	Luminous Efficiency (lm/W)
		Min.	Max.	Typ.	Typ.
ASMT-MWx <sub>2</sub> 9-NLLxx	Cool White	4000	10000	120	64
ASMT-MYx <sub>2</sub> 9-NKLxx	Warm White	2600	4000	120	58
ASMT-MWx <sub>2</sub> 9-NKLxx	Cool White Diffused	4000	10000	120	58
ASMT-MYx <sub>2</sub> 9-NKLxx	Warm White Diffused	2600	4000	120	54

Notes:

1. θ<sub>½</sub> is the off-axis angle where the luminous intensity is ½ the peak intensity.

## Electrical Characteristic at 350 mA (T<sub>J</sub> = 25°C)

Dice Type	Forward Voltage, V <sub>F</sub> (Volts) at I <sub>F</sub> = 350mA			Thermal Resistance, R <sub>θj-ms</sub> (°C/W) <sup>[1]</sup>
	Min.	Typ.	Max.	Typ.
InGaN	3.2	3.6	4.0	10

Note:

1. R<sub>θj-ms</sub> is the Thermal Resistance from LED junction to metal slug.

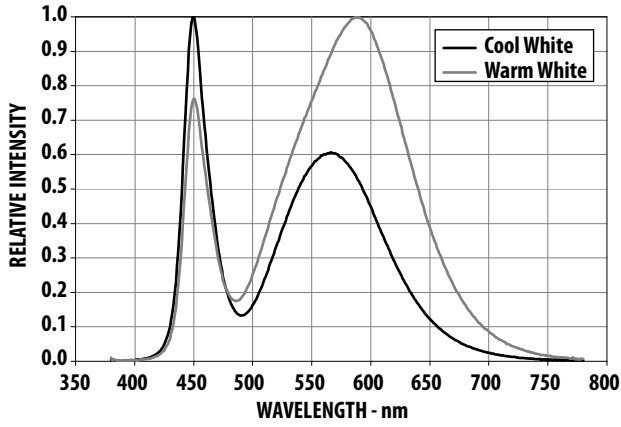

Figure 4. Relative intensity vs. wavelength

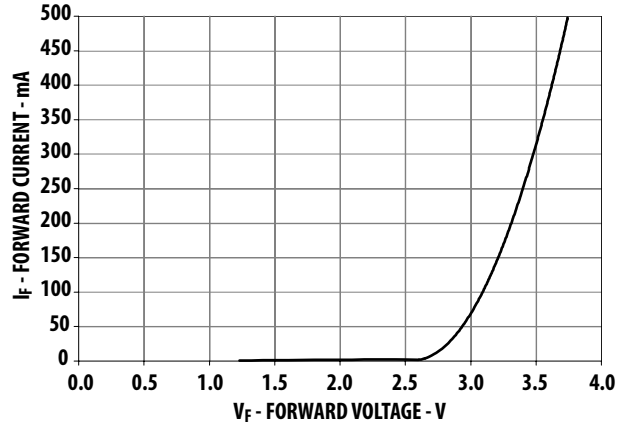

Figure 5. Forward voltage vs. forward current.

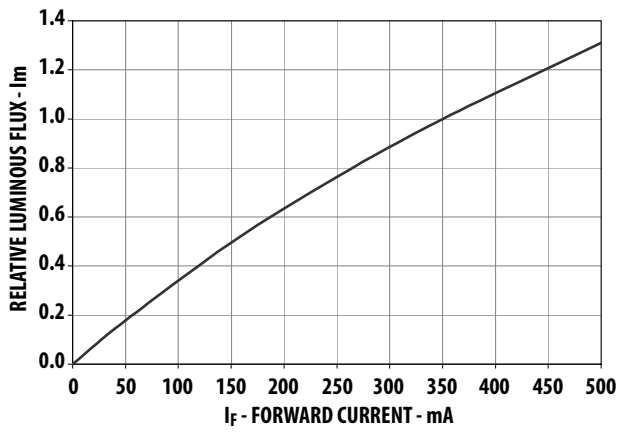

Figure 6. Relative luminous flux vs. forward current.

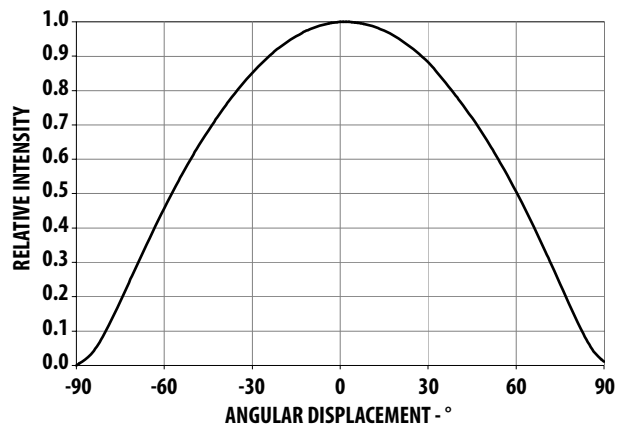

Figure 7. Radiation pattern.

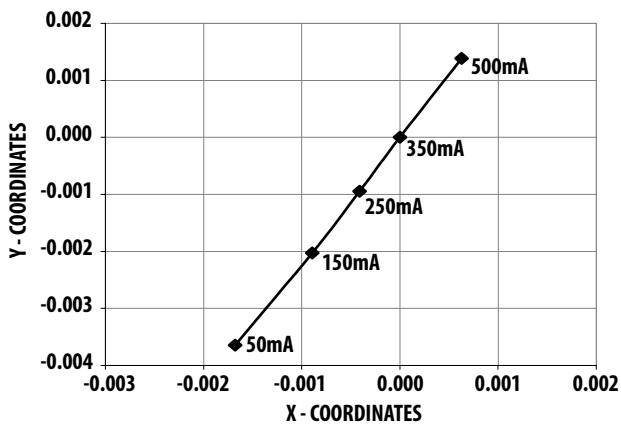

Figure 8. Chromaticity coordinate shift vs. forward current (Cool White).

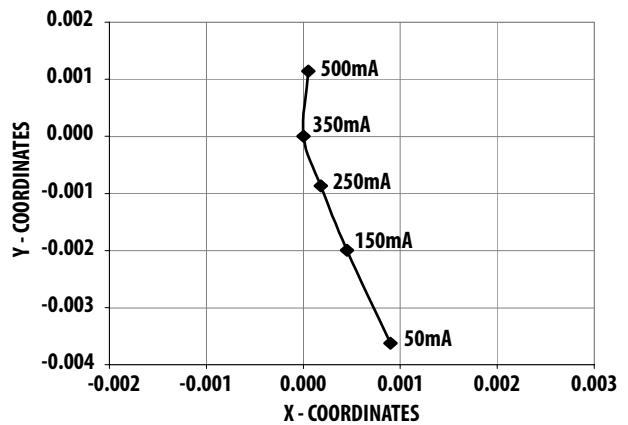

Figure 9. Chromaticity coordinate shift vs. forward current (Warm White).

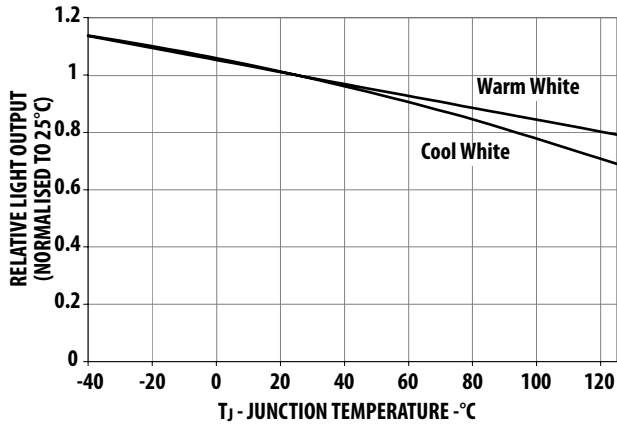

Figure 10. Relative light output vs. junction temperature.

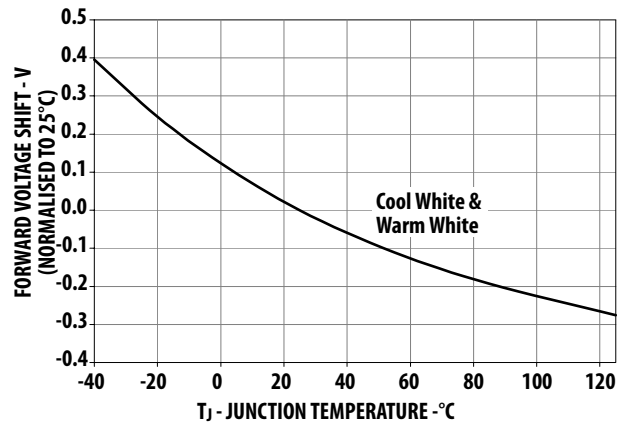

Figure 11. Forward voltage shift vs. junction temperature.

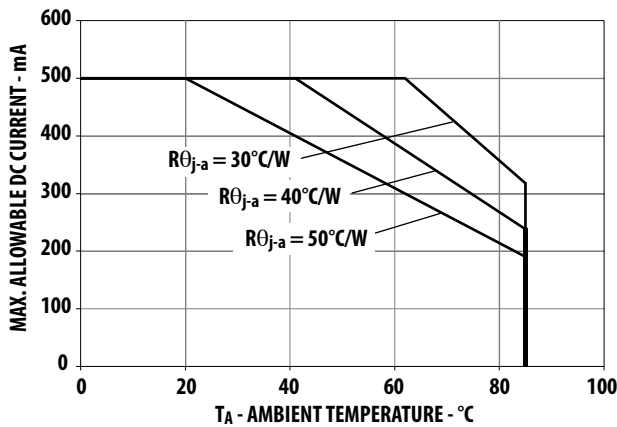

Figure 12. Maximum forward current vs. ambient temperature

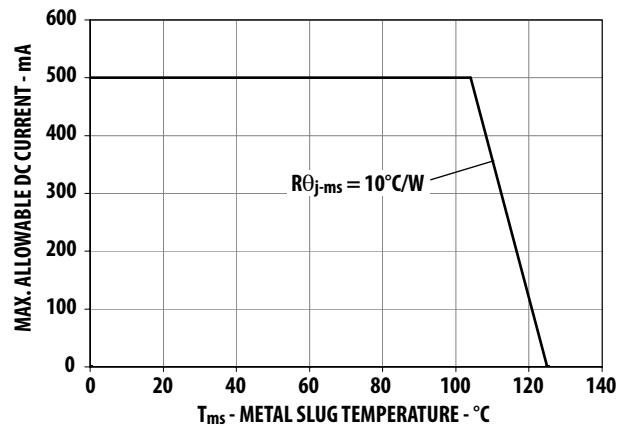

Figure 13. Maximum forward current vs. metal slug temperature

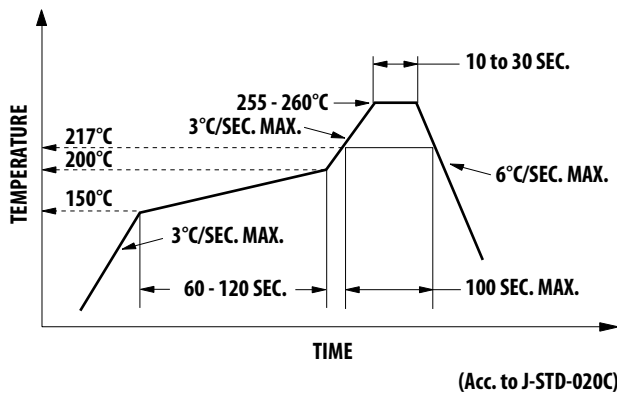

Figure 14. Recommended soldering profile.

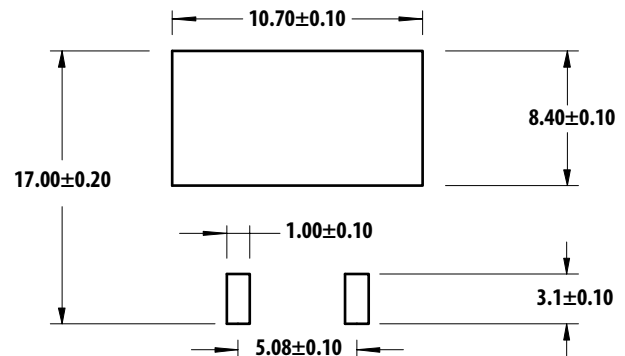

Figure 15 Recommended soldering land pattern.

Note:

For detail information on reflow soldering of Avago surface mount LEDs, do refer to Avago Application Note AN1060 Surface Mounting SMT LED Indicator Components.

## Option Selection Details

ASMT-Mxx9 – N x<sub>3</sub> x<sub>4</sub> x<sub>5</sub> x<sub>6</sub>

x<sub>3</sub> = Minimum flux bin

x<sub>4</sub> = Maximum flux bin

x<sub>5</sub> = Color Bin Selection

x<sub>6</sub> = Packaging Option

## Flux Bin Limit [x<sub>3</sub> x<sub>4</sub>]

Bin	Luminous Flux (lm) @ I <sub>F</sub> = 350mA	
	Min	Max
K	56.0	73.0
L	73.0	95.0
M	95.0	124.0

Tolerance: ±10%

## Color Bin Selections [x<sub>5</sub>]

Individual reel or tube will contain LEDs from one color bin only.

### Cool White

Selection	Bin
0	Full Distribution
A	A only
B	B only
C	C only
D	D only
E	E only
F	F only
G	G only
H	H only
L	A and G only
M	B and H only
N	A and C only
P	B and D only
Q	E and C only
R	F and D only
S	G and H only
U	E and F only
W	C and D only
Z	A and B only
1	A, B, C and D only
2	G, H, A and B only
4	C, D, E and F only

### Warm White

Selection	Bin
0	Full Distribution
A	A only
B	B only
C	C only
D	D only
E	E only
F	F only
N	A and C only
P	B and D only
Q	E and C only
R	F and D only
U	E and F only
W	C and D only
Z	A and B only
1	A, B, C and D only
4	C, D, E and F only

### Color Bin Limit

Cool White	Color Limits (Chromaticity Coordinates)				
		X	Y	X	Y
Bin A	X	0.367	0.362	0.329	0.329
	Y	0.400	0.372	0.345	0.369
Bin B	X	0.362	0.356	0.329	0.329
	Y	0.372	0.330	0.302	0.345
Bin C	X	0.329	0.329	0.305	0.301
	Y	0.369	0.345	0.322	0.342
Bin D	X	0.329	0.329	0.311	0.305
	Y	0.345	0.302	0.285	0.322
Bin E	X	0.303	0.307	0.283	0.274
	Y	0.333	0.311	0.284	0.301
Bin F	X	0.307	0.311	0.290	0.283
	Y	0.311	0.285	0.265	0.284
Bin G	X	0.388	0.379	0.362	0.367
	Y	0.417	0.383	0.372	0.400
Bin H	X	0.379	0.369	0.356	0.362
	Y	0.383	0.343	0.330	0.372

Tolerance:  $\pm 0.01$

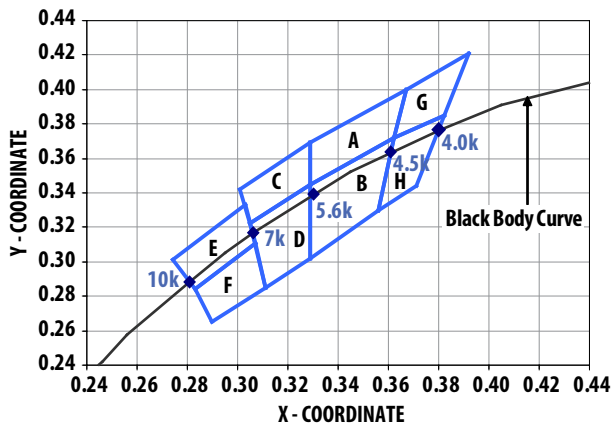

Figure 16. Color bins (Cool White)

### Packaging option [x<sub>6</sub>]

Selection	Option
0	Tube (for Moonstone® only) Tray (for Moonstone® on MCPCB only)
1	Tape & reel

Warm White	Color Limits (Chromaticity Coordinates)				
		X	Y	X	Y
Bin A	X	0.452	0.488	0.470	0.438
	Y	0.434	0.447	0.414	0.403
Bin B	X	0.438	0.470	0.452	0.424
	Y	0.403	0.414	0.384	0.376
Bin C	X	0.407	0.418	0.452	0.438
	Y	0.393	0.422	0.434	0.403
Bin D	X	0.395	0.407	0.438	0.424
	Y	0.362	0.393	0.403	0.376
Bin E	X	0.381	0.387	0.418	0.407
	Y	0.377	0.404	0.422	0.393
Bin F	X	0.373	0.381	0.407	0.395
	Y	0.349	0.377	0.393	0.362

Tolerance:  $\pm 0.01$

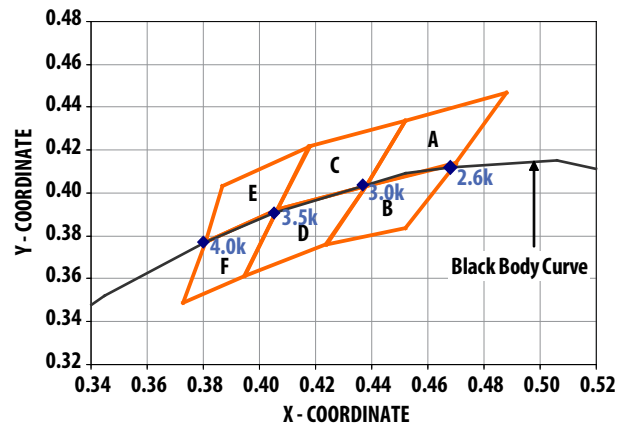

Figure 17. Color bins (Warm White)

### Example

#### ASMT-MW09-NLLZ1

- ASMT-MW09-Nxxxx – Cool White Non-diffused
- x<sub>1</sub> = L – Min. flux bin L
- x<sub>2</sub> = L – Max. flux bin L
- x<sub>3</sub> = Z – Color bin A & B only
- x<sub>4</sub> = 1 – Tape & reel option



### Packing Tube - Option 0

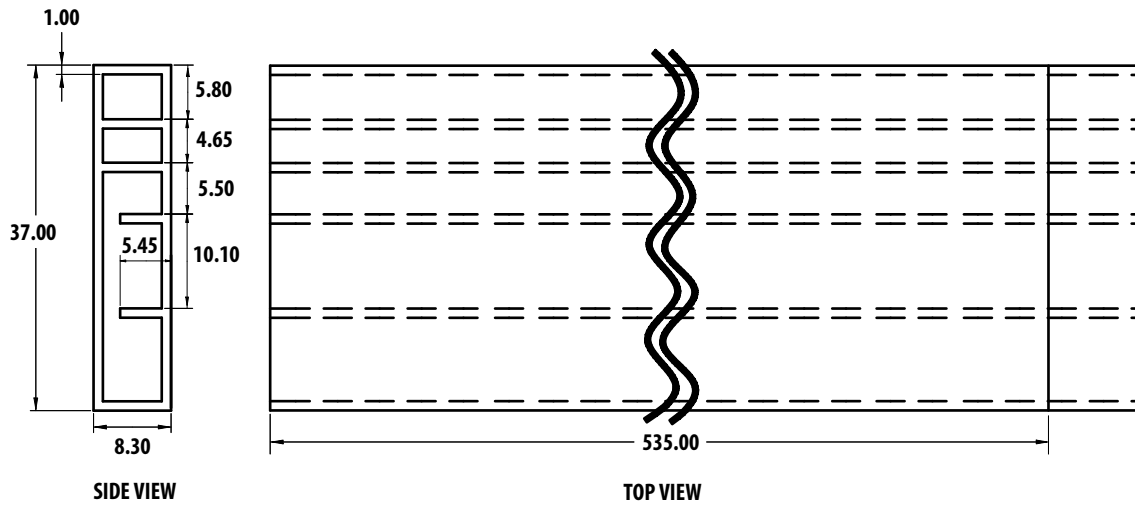

Quantity per tube = 25 pcs

Figure 18. Tube dimensions

### Tape and Reel - Option 1

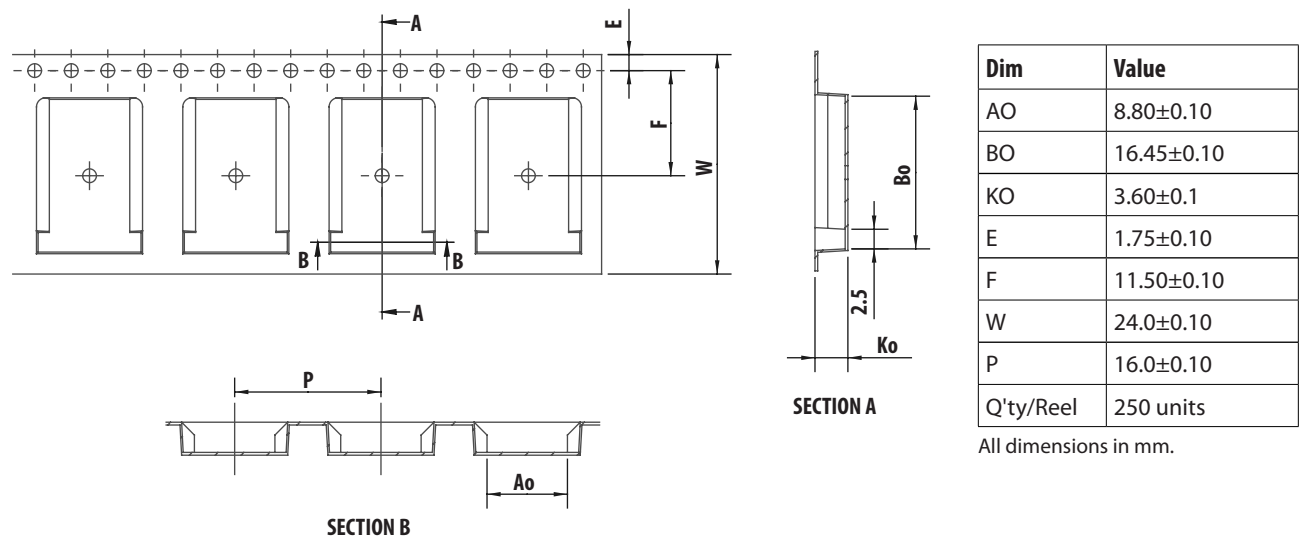
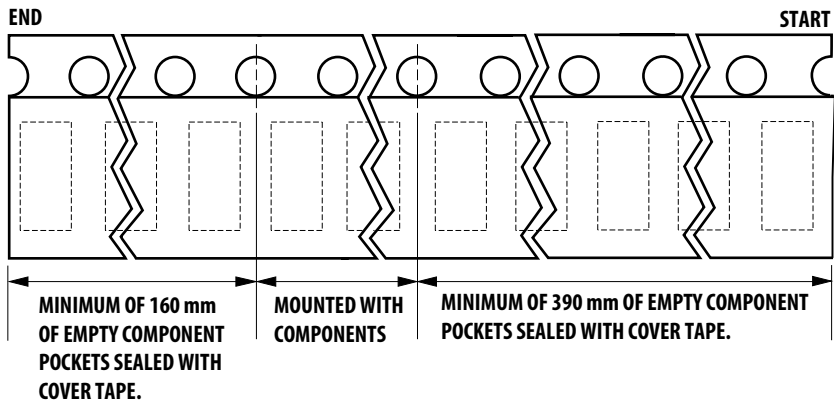

Figure 19. Carrier tape dimensions



\*Note: Tape & Reel Packaging only applicable as per this datasheet only.

Figure 20. Carrier tape leader and trailer dimensions

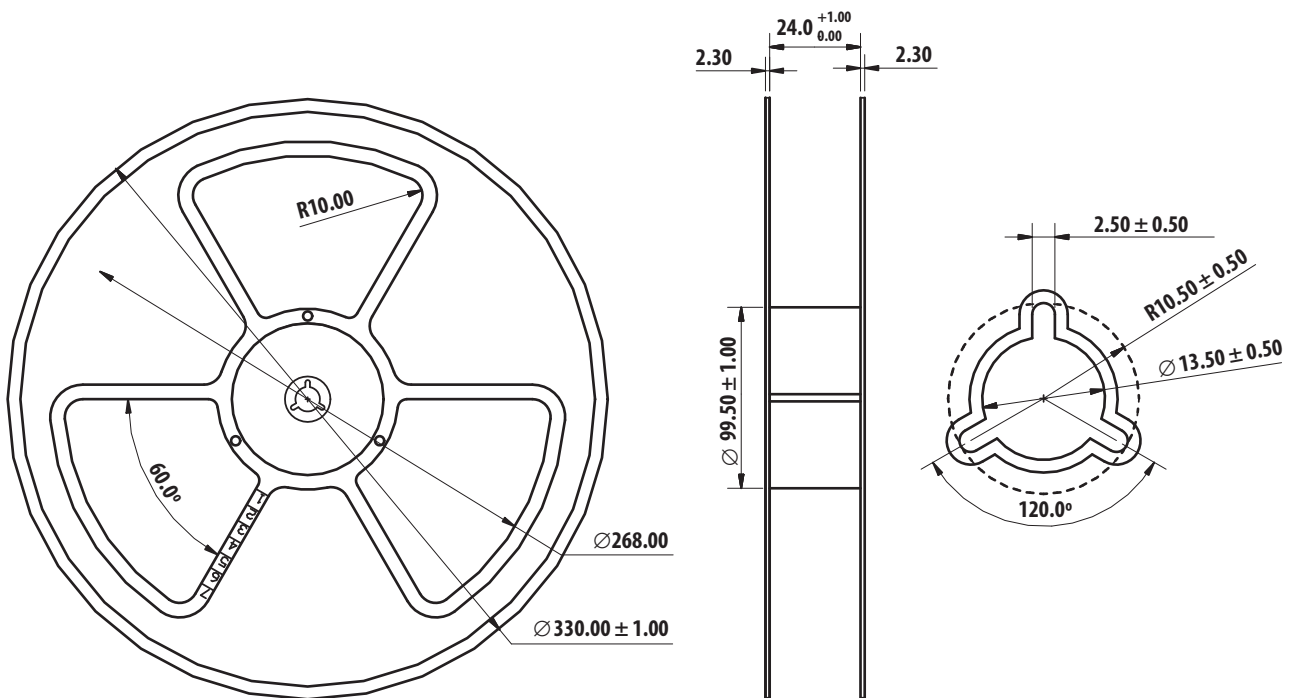
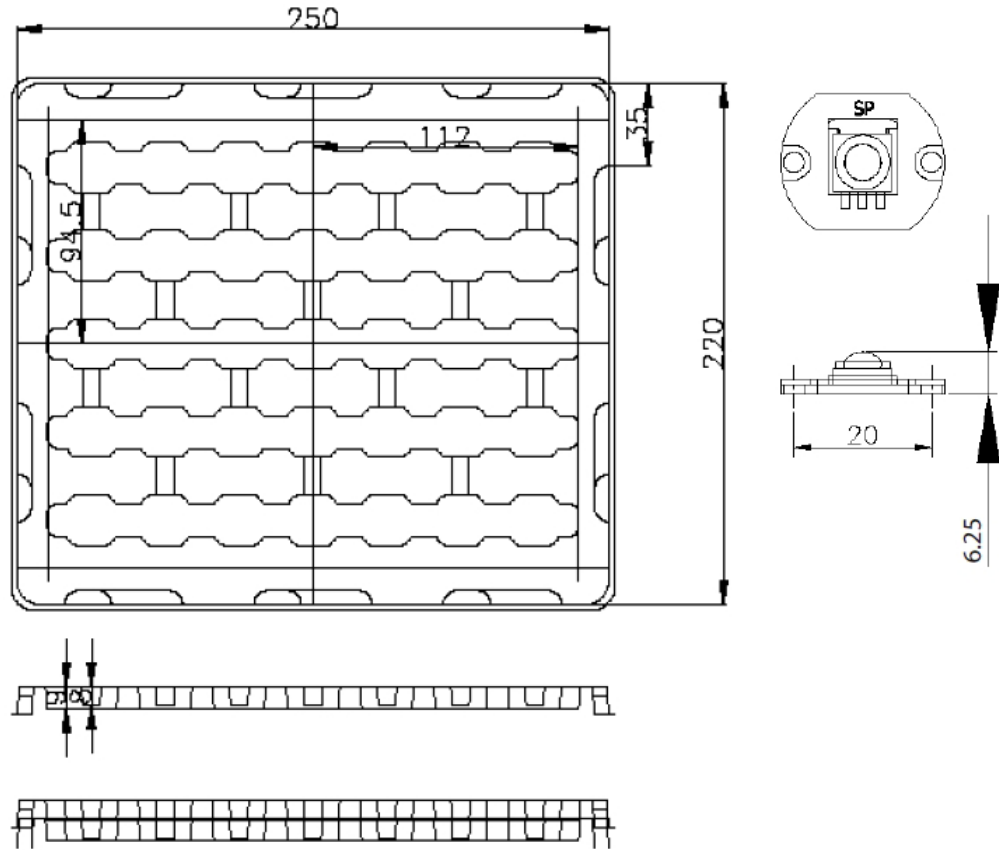

Figure 21. Reel dimensions

**Packing Tray - Option 0 (for Moonstone® on MCPCB only)**



**Figure 22. Tray dimensions.**

## Handling Precaution

The encapsulation material of the product is made of silicone for better reliability of the product. As silicone is a soft material, please do not press on the silicone or poke a sharp object onto the silicone. These might damage the product and cause premature failure. During assembly or handling, the unit should be held on the body only. Please refer to Avago Application Note AN 5288 for detail information.

## Moisture Sensitivity

This product is qualified as Moisture Sensitive Level 4 per Jedec J-STD-020. Precautions when handling this moisture sensitive product is important to ensure the reliability of the product. Do refer to Avago Application Note AN5305 Handling of Moisture Sensitive Surface Mount Devices for details.

### A. Storage before use

- Unopen moisture barrier bag (MBB) can be stored at <math>40^{\circ}\text{C}/90\%RH</math> for 12 months. If the actual shelf life has exceeded 12 months and the humidity indicator card (HIC) indicates that baking is not required, then it is safe to reflow the LEDs per the original MSL rating.
- It is not recommended to open the MBB prior to assembly (e.g. for IQC).

### B. Control after opening the MBB

- The humidity indicator card (HIC) shall be read immediately upon opening of MBB.
- The LEDs must be kept at <math>30^{\circ}\text{C}/60\%RH</math> at all time and all high temperature related process including soldering, curing or rework need to be completed within 72 hours.

### C. Control for unfinished reel

- For any unused LEDs, they need to be stored in sealed MBB with desiccant or desiccator at <math>5\%RH</math>.

### D. Control of assembly boards

- If the PCB soldered with the LEDs is to be subjected to other high temperature processes, the PCB need to be stored in sealed MBB with desiccant or desiccator at <math>5\%RH</math> to ensure no LEDs have exceeded their floor life of 72 hours.

### E. Baking is required if

- HIC "10%" indicator is not blue and "5%" indicator is pink.
- The LEDs are exposed to condition of <math>30^{\circ}\text{C}/60\%RH</math> at any time.
- The LEDs floor life exceeded 72hrs.

Recommended baking condition:  $60\pm 5^{\circ}\text{C}$  for 20hrs.

For product information and a complete list of distributors, please go to our web site: [www.avagotech.com](http://www.avagotech.com)