

DRAWING MADE IN THIRD ANGLE PROJECTION
 THIS DRAWING IS UNPUBLISHED. RELEASED FOR PUBLICATION
 © COPYRIGHT 19 BY AMP INCORPORATED, HARRISBURG, PA. ALL INTERNATIONAL RIGHTS RESERVED. AMP PRODUCTS MAY BE COVERED BY U.S. AND FOREIGN PATENTS AND/OR PATENTS PENDING.

LOC		DIST		REV		ZONE		LTR		DESCRIPTION		DATE	APPD
BD	77									D	REV PER EC 0020-983-95	15 DEC 95	RT
										E	REV PER EC 0020-1448-95	11 JAN 96	RLT
										F	SUPSD -1 PER EC 0020-570-96	28 FEB 97	RT

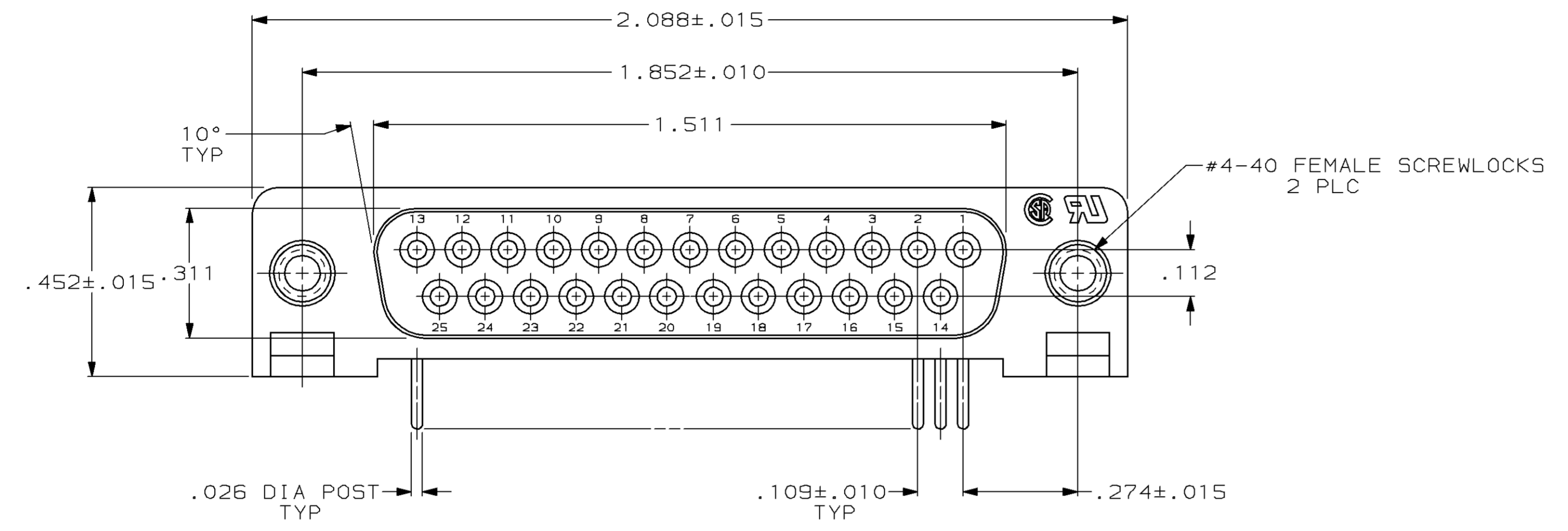

- ① FLAME RETARDANT, 94V-0 RATED, GLASS FILLED NYLON OR POLYESTER, COLOR: BLACK.
- ② PHOS. BRONZE PER QQ-B-750.
- ③ REFER TO APPLICATION SPEC FOR RECOMMENDED P.C. BOARD MOUNTING DIMENSIONS FOR AUTOMATIC INSERTION.
- ④ GOLD PLATING PER MIL-G-45204, TIN PLATING PER MIL-T-10727, NICKEL PLATING PER QQ-N-290.
- ⑤ PLATED WITH GOLD FLASH FOR LENGTH OF .055 MIN FROM MATING END, WITH POINT OF MEASUREMENT .035 FROM MATING END OF CONTACT, .000100-.000200 TIN OR TIN-LEAD ON SOLDER END, ALL OVER .000050 NICKEL ON ENTIRE CONTACT.
- ⑥ PLATED WITH .000030 GOLD FOR LENGTH OF .055 MIN FROM MATING END, WITH POINT OF MEASUREMENT .035 FROM MATING END OF CONTACT, .000100-.000200 TIN OR TIN-LEAD ON SOLDER END, ALL OVER .000050 NICKEL ON ENTIRE CONTACT.

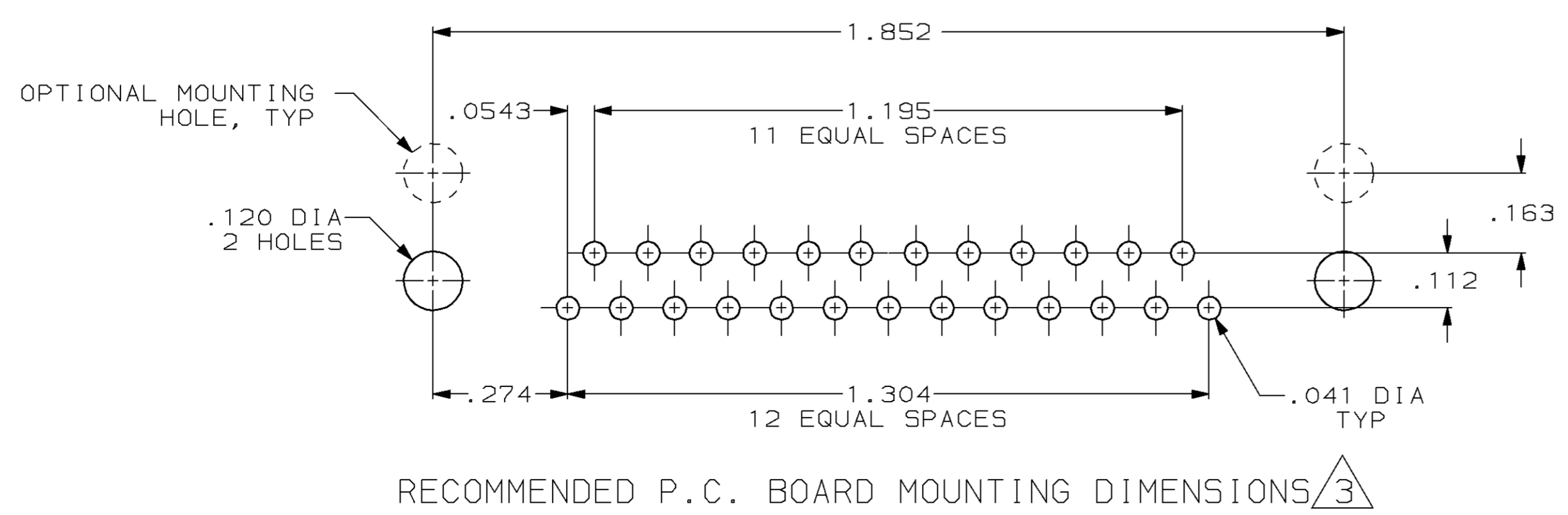
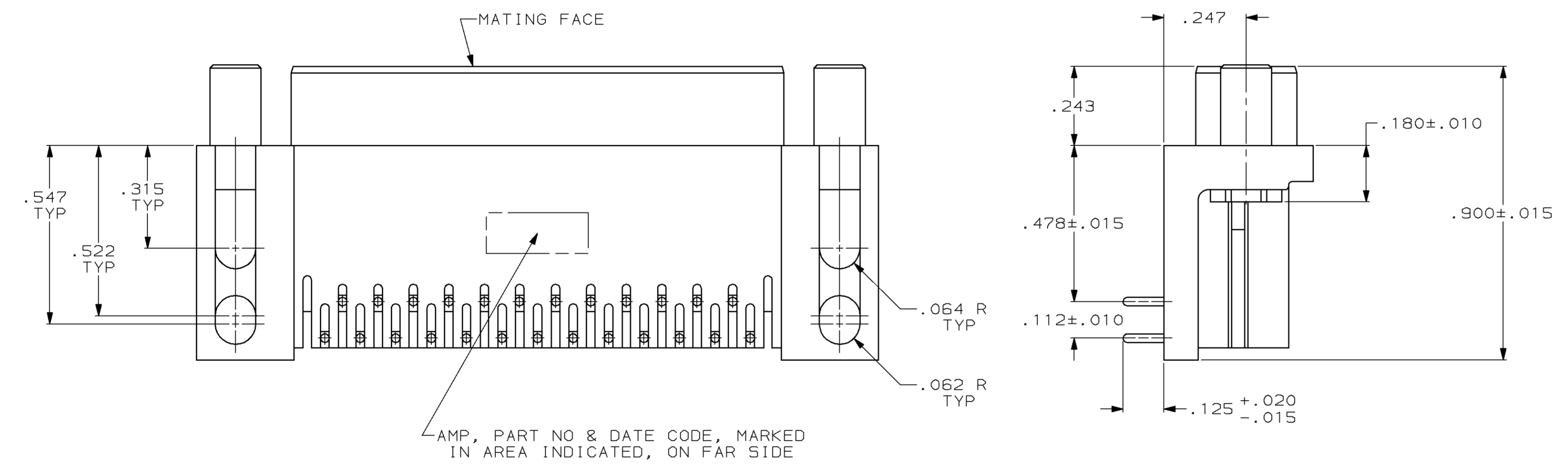

UNLESS OTHERWISE SPECIFIED DIMENSIONS ARE IN INCHES TOLERANCES ON :		DR 5-5-87 S.WELDON	AMP INCORPORATED Harrisburg, Pa. 17105
2 PL DEC ± .005		CHK 5-5-87 C.RICHARD	
3 PL DEC ± .005		APPD 5-5-87 B.TAYLOR	NAME RECEPTACLE ASSY, SIZE 3, 25 POSN, RIGHT ANGLE, .478 SERIES, .026 DIA POSTS, W/ FEMALE SCREWLOCKS, AMPLIMITE® HD-20
ANGLES ± 2°		APPD 5-5-87 J.ASSINI	SIZE D
MATERIAL		PRODUCT SPEC 108-40005	FSCM NO 00779
MOULDED PARTS: ①		APPLICATION SPEC 114-40015	DRAWING NO 745398
CONTACTS: ②		WEIGHT -	SCALE 4:1
SCREWLOCKS: ④ ZINC			SHEET 1 of 1
FINISH: ⑤			
CONTACTS: SEE TABLE			
SCREWLOCKS: CLEAR CHROMATE			