

LOC	DIST	P	F	ZONE	LTR	REVISIONS	DATE	APPD	
BD	26					0	RELEASED NPR 4572 WAS 92-4264-35-1	02/04/93	-
						01	ADDED -2 PER NPR 4767	05/11/93	RB
						A	REV PER EC 0020-824-95	13 OCT 95	JH
						B	REV PER EC 0410-95-96	03 MAR 97	JGH
						C	REV PER EC 0410-281-97	29 SEP 97	JGH
						D	REV PER EC 0410-410-97	06 FEB 98	JGH

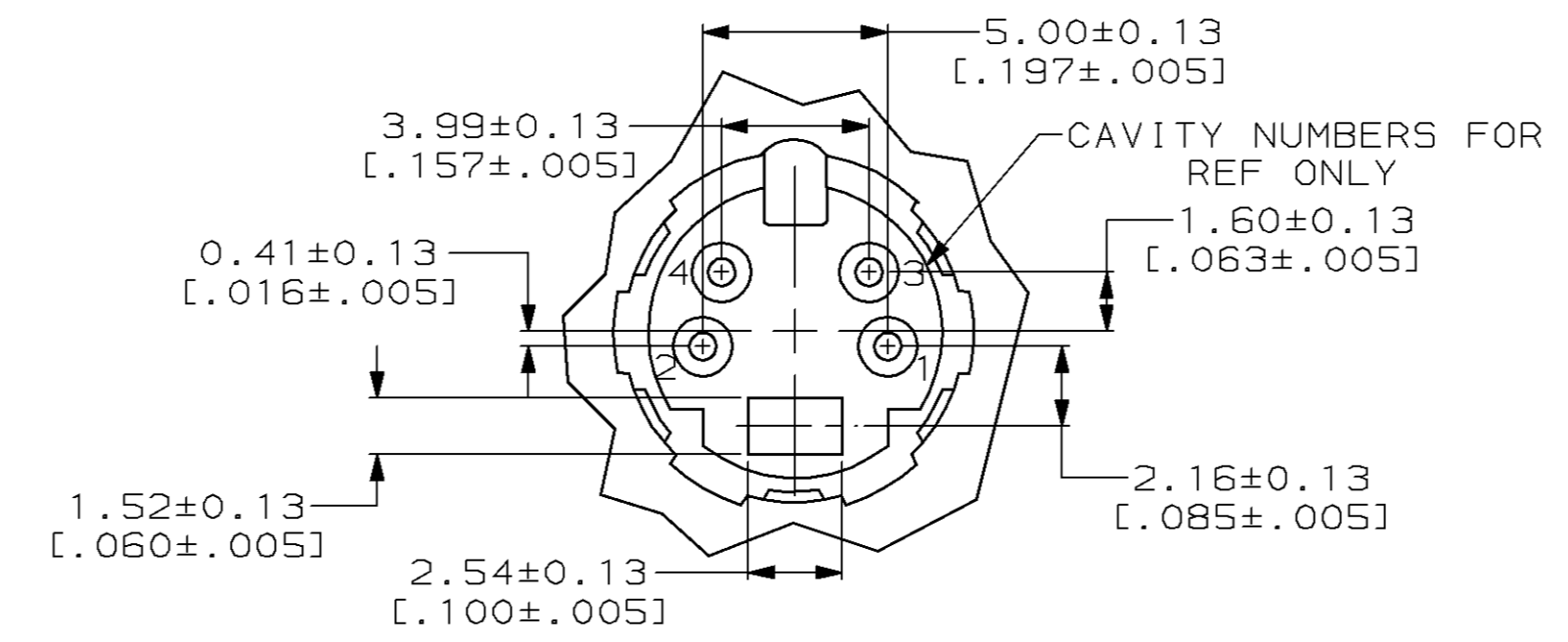

- 1 POLYESTER, UL 94V-0 RATED, PLATINUM GRAY.
- 2 COPPER ALLOY.
- 3 GOLD PLATING PER MIL-G-45204, TIN PLATING PER MIL-T-10727, NICKEL PLATING PER QQ-N-290.
- 4 0.76µm [0.00030] MIN GOLD FOR A LENGTH OF 1.52 [0.060] MIN FROM MATING END, 3.05µm [0.00120] MIN TIN-LEAD ON OPPOSITE END, BOTH OVER 1.27µm [0.00050] MIN NICKEL, ENTIRE CONTACT.
- 5 1.50-4.00µm [0.00059-.00158] THICK BRIGHT TIN.
- 6 786728-2 ONLY: LETTER S IS MARKED AS SHOWN.
- 7 DATUMS AND BASIC DIMENSION SUPPLIED BY CUSTOMER.

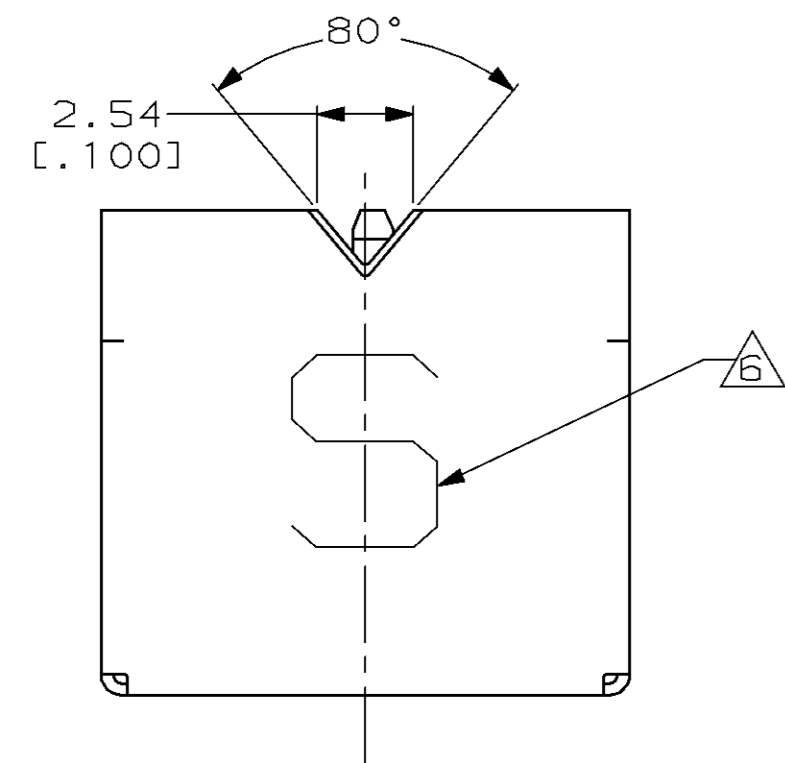
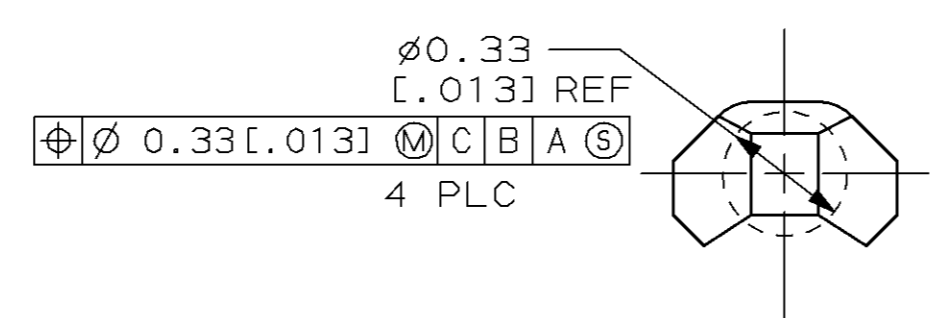
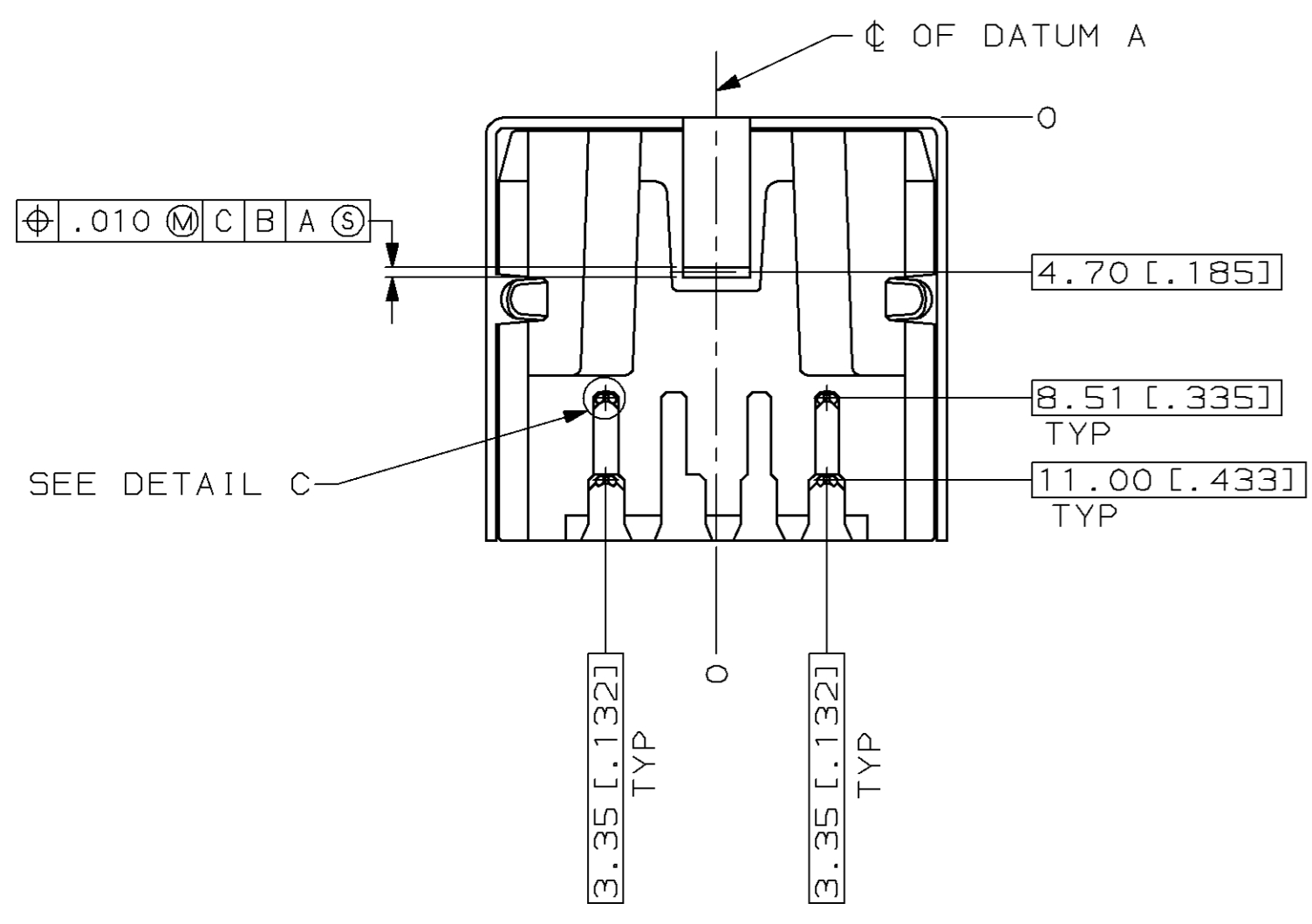
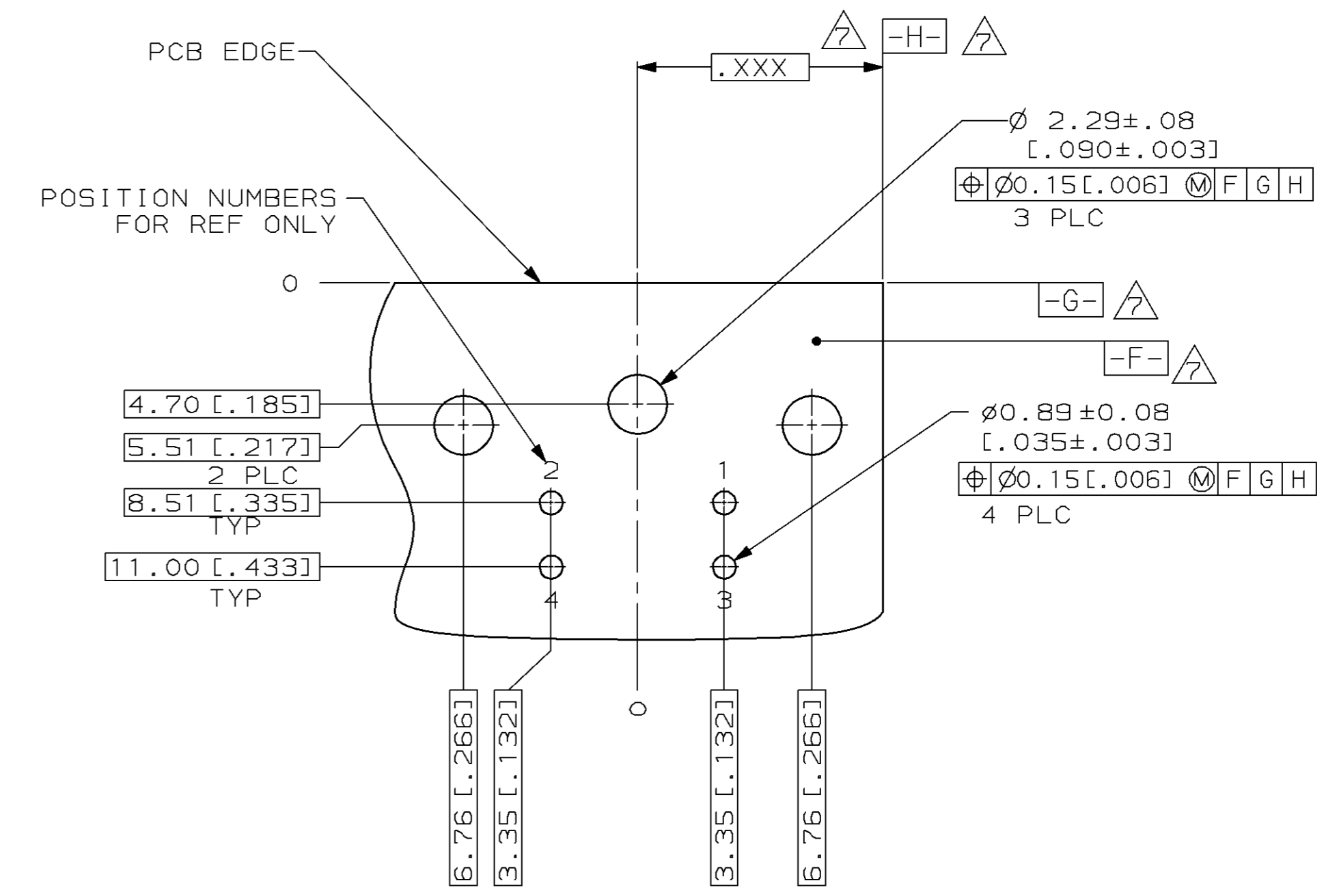
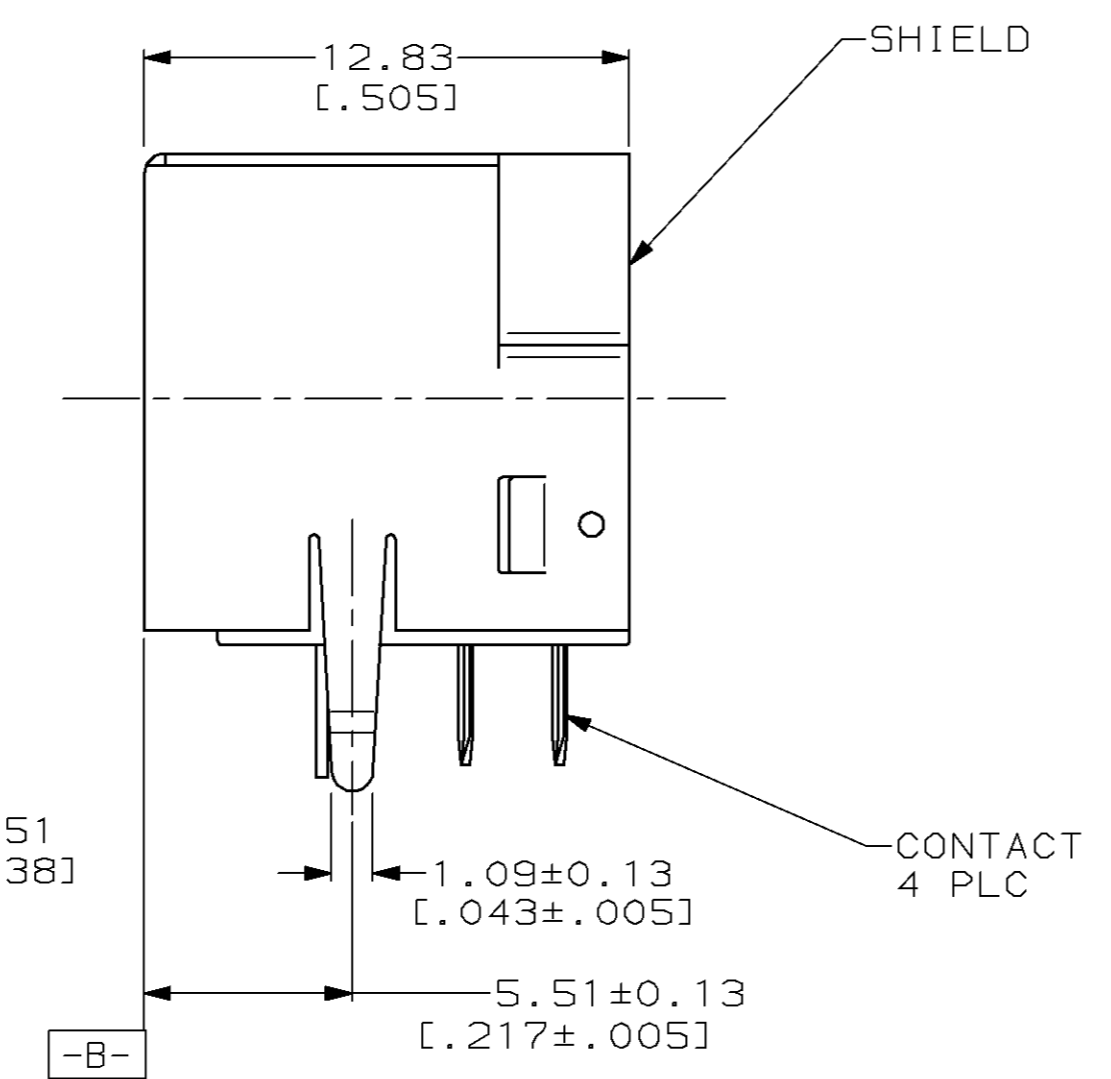
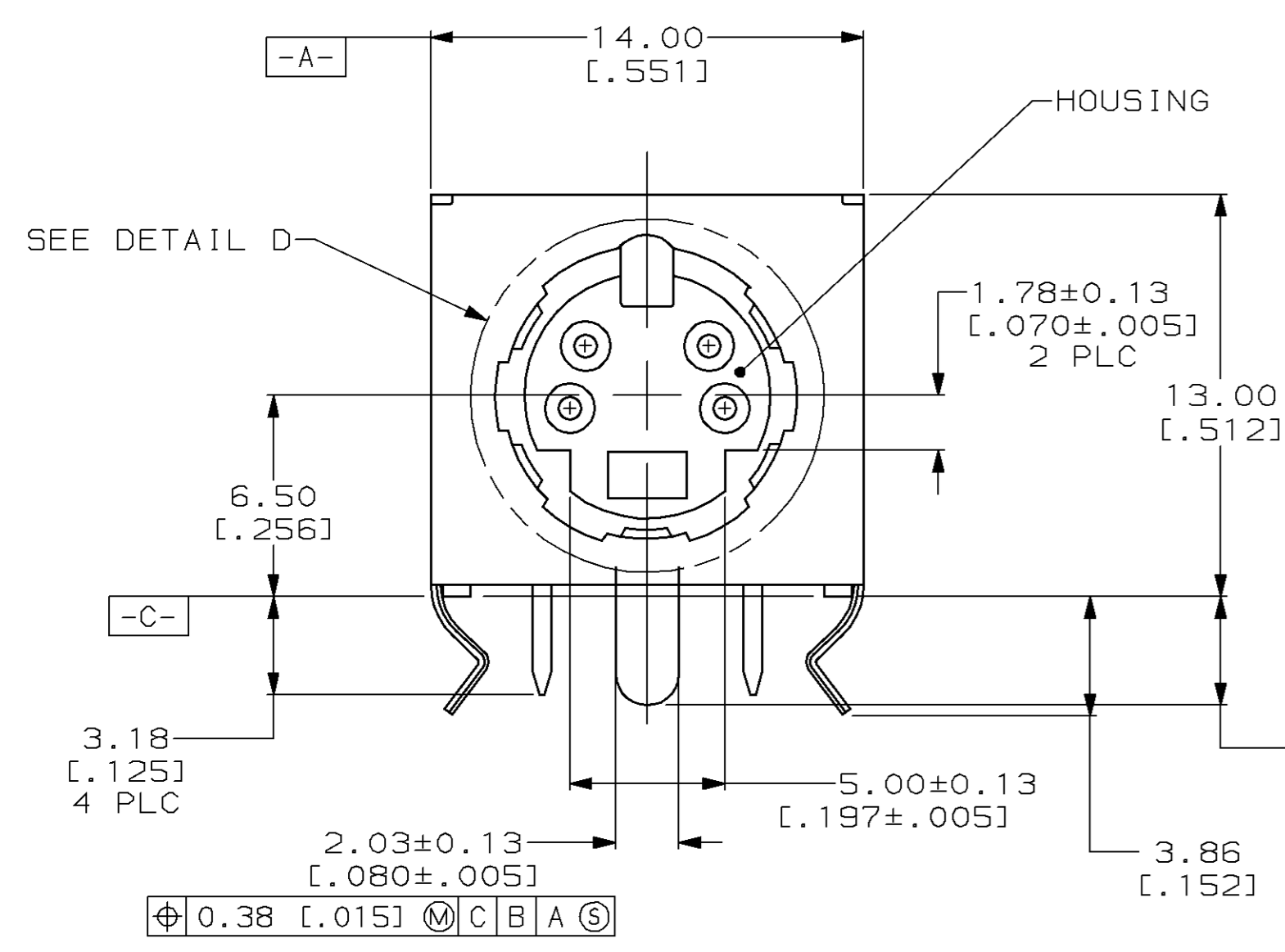

DETAIL C  
SCALE 50:1

RECOMMENDED PC BOARD LAYOUT  
BOTTOM VIEW

786728-2
786728-1
PART NO

DO NOT SCALE PRINT. UNLESS SPECIFIED DIMENSIONS IN mm [INCHES] TOLERANCES ON: 2 PLC DEC ± 0.38 [0.015] 3 PLC DEC ± - ANGLES ± 0°30'	DR 02/04/93 C.DORWART CHK 02/10/93 W.LENKER APPD 02/12/93 R.BYERS APPD 02/12/93 C.HAMMAKER PRODUCT SPEC 108-1225 APPLICATION SPEC 114-40031 WEIGHT -	<p><b>AMP</b> AMP Incorporated Harrisburg, PA 17105-3608</p> <p>NAME RECEPTACLE ASSEMBLY, WITH HOLD DOWN, 4 POSITION, RIGHT ANGLE, MINIATURE CIRCULAR DIN</p> <p>SIZE D CAGE CODE 00779 DRAWING NO C-786728 SCALE 5:1 SHEET 1 OF 1</p>
---	--	--

THIS DRAWING IS A CONTROLLED DOCUMENT FOR AMP INCORPORATED. IT IS SUBJECT TO CHANGE AND THE CONTROLLING ENGINEERING ORGANIZATION SHOULD BE CONTACTED FOR THE LATEST REVISION.