

This document is the property of Amphenol Corporation and is delivered on the express condition that it is not to be disclosed, reproduced or used, in whole or in part, for manufacture or sale by anyone other than Amphenol Corporation without its prior consent, & that no right is granted to disclose or to use any information in this document.

REVISIONS				
SYM	ECN	DESCRIPTION	DATE	APPROVED
A	HK	INITIAL RELEASE	06/11/03	Y.M.LEE
1	HK	ADD CHOP OF ROHS'	10/25/10	IP

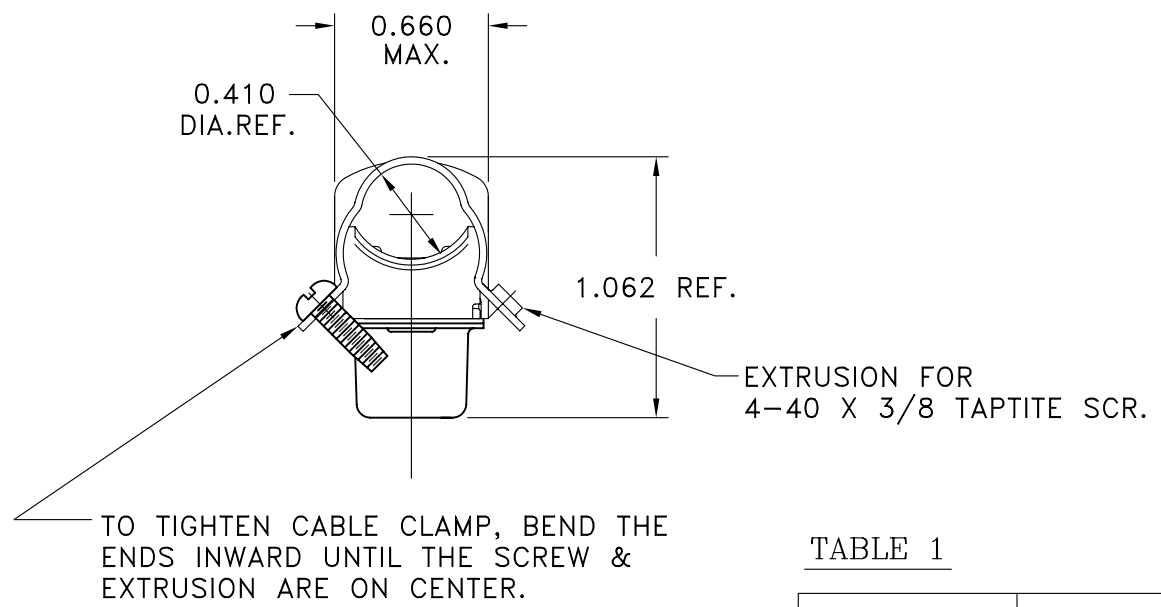
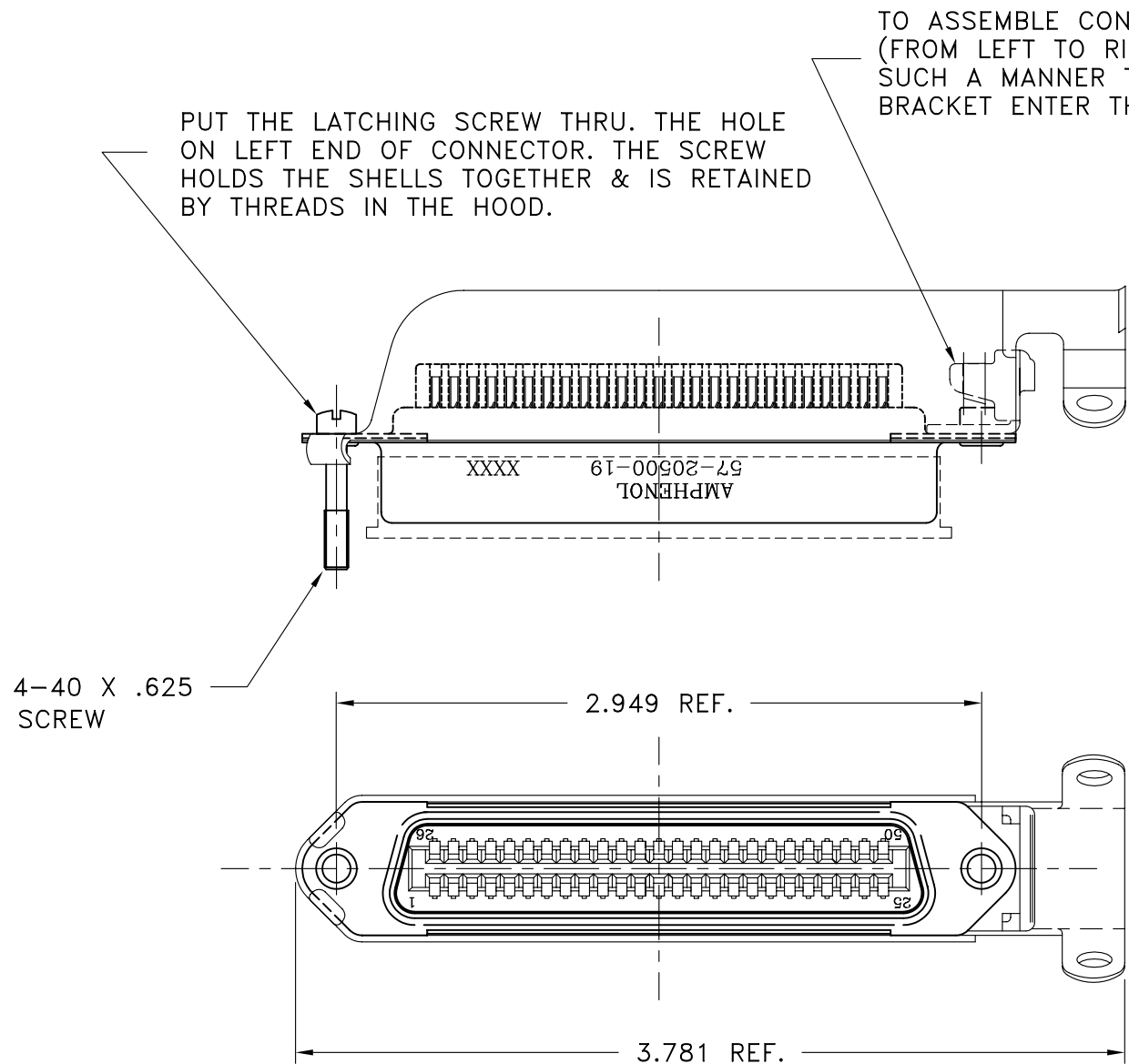

TABLE 1

CONNECTOR SIZES	AVERAGE MATING FORCE (POUNDS)
14	5
24	8
36	12
50	15
64	19



SPECIFICATIONS:

- 1) SOLDER CUP CONTACT: TO ACCOMMODATE 22-30 AWG SOLID AND 24-30 STRANDED CONNECTOR WIRES.
- 2) DIELECTRIC: DIALYL-PHTHALATE PER MIL-M-14F TYPE MDG UL-94V0
- 3) CONTACT MATERIAL: COPPER ALLOY
- 4) CONTACT: 20 MICRO-INCHES MIN. GOLD MATING AREA: 3-5 MICRO-INCHES GOLD TERMINAL AREA: 50 MICRO-INCHES MIN. NICKEL UNDERPLATING ALL OVER.
- 5) SHELL MATERIAL: ZINC PLATED STEEL WITH CLEAR CHROMATE COATING
- 6) CURRENT CAPACITY: 5 AMPS MAX
- 7) VOLTAGE RATING: 700 VOLTS D.C. AT SEA LEVEL
200 VOLTS D.C. AT 70,000 FEET
- 8) INSULATION RESISTANCE: >5000 M OHM
- 9) DIELECTRIC WITHSTANDING VOLTAGE: 1200 VAC (RMS) AT SEA LEVEL
- 10) CONNECTOR MATING FORCE: REFER TO TABLE 1.

- 11) CONTACT RETENTION FORCE: 2 LBS
- 12) DURABILITY: 250 CYCLES MIN.
- 13) VIBRATION: NO INTERRUPTIONS < 1u SEC.
- 14) OPERATING TEMPERATURE: -55°C TO +105°C (-67°F TO +221°F)
- 15) MATERIAL SHOULD BE FULFILLED AMPHENOL SPEC.# SSN001.

CUSTOMER INFORMATION DRAWING

ITEM NO	PART OR IDENTIFICATION NO	NOMENCLATURE OR DESCRIPTION	QTY REQ'D
PARTS LIST			
UNLESS OTHERWISE SPECIFIED TOLERANCES		APPROVAL	DATE
U.S. METRIC		DRAWN XS.GUO	10/25/10
.X +/- 0.020		CHECKED	
.XX +/- 0.010		CHECKED	
.XXX +/- 0.005		TITLE 50 CONTACT RECEPT. ASSEMBLY	
FRACTIONS +/-		RUNNING CABLE 25-50 END,	
ANGLES +/- 1°		DUST COVER	
FOR MATERIALS AND FINISHES SEE NOTES		DRAWING FILE : \DRAWING\157\C572050019.DWG	
REMOVE SHARP EDGES		ANGLE OF PROJECTION	
DIMENSIONS		SIZE DRAWING NO. REV.	
U.S. INCHES		A3 C57-20500-19 1	
-(METRIC)- (MM)-		SCALE NONE SHEET 1 OF 1	