

4

3

DRW NO. C-471-1025-500	SH 1	REV N
---------------------------	---------	----------

ZONE	REV	SCR NUMBER	DESCRIPTION	BY	DATE	APPROVED
	G	JPRX-7ESPW4.VER01	ADDED P/N 471-1045-104 AND 471-1045-604	HCL-AP	05/15/08	J.PROULX
	H	JPRX-7PNHRT.VER01	ADDED P/N 471-3025-101 AND 471-3025-601	HCL-RB	03/09/09	J.PROULX
	J	JPRX-7TBGML.VER01	ADDED P/N 471-2095-101 AND 471-2095-601	HCL-MH	07/02/09	J.PROULX
-	K	CSAS-82ATTZ.VER01	ADDED NEW PART NUMBERS IN TABLES FOR NEW PLATING CODES. ADDED 471-2065-X01 & 471-3095-X00 PART NUMBERS IN TABLE 1	HCL-MH	02/12/2010	C.SAMMIS
	L	JPRX-86EPK6.VER01	ADDED P/N 471-2045-X03	HCL-BK	06/15/2010	C.SAMMIS
	M	CSAS-8XGS99.VER01	ADDED P/N 471-2025-X04 IN TABLE 1	HCL-MP	08/28/2012	C.SAMMIS
SH1.A4	N	MCHH-9TUTMD.VER01	CHANGED NOTE 4 TO AVOID AMBIGUITY ABOUT TOOLING HOLES	M.CHARETH	02/18/2015	J.PROULX

B

B

NOTES;

1. ALL DIMENSIONS ARE IN MM.
2. MAT'L: HOUSING/WAFERS/VACUUM CAP - LCP
CONTACTS - HIGH PERFORMANCE COPPER ALLOY,
PER MTS-506.
3. 0.71 DIA SOLDER SPHERES WILL NOT BE PERFECTLY
PHERICAL AFTER REFLOW ATTACHMENT.
4. TOOLING HOLES USED FOR INTERNAL PROCESS ALIGNMENT AND NOT REQUIRED
FOR SMT PROCESS ALIGNMENT. QUANTITY OF TOOLING HOLES IS OPTIONAL, AT
MANUFACTURERS DISCRETION.
5. SOLDER BALL PROTRUSION BELOW HOUSING.
6. SEE TECHNICAL BULLETIN TB-2082 FOR DETAILED SMT PROCESSING
AND PCB FOOT PRINT RECOMMENDATIONS.
7. MAXIMUM CO-PLANARITY OF THE BALL FIELD.
8. MAXIMUM TRUE POSITION OF ANY SOLDER BALL
IN RELATION TO AN IDEAL BEST FIT GRID.
9. TOLERANCES DO NOT APPLY TO REFERENCE DIMENSIONS
SHOWN IN "()" OR BASIC DIMENSIONS SHOWN IN "□".

A

4

3

2

1

TOLERANCES		DESIGN 7/7/99 D. MCNAMARA	Amphenol TCS A Division of Amphenol Corporation 200 Innovative Way, Nashua, NH 03062 603.879.3000
0.0	±0.25	DRAWN 2/10/00 RJ MCISAAC	
0.00	±0.13	CHK 06/21/02 J.MARVIN	
0.000	± -	APVD 2/6/04 J.MARVIN	
ANGLES	± -		
UNLESS OTHERWISE SPECIFIED DIMENSIONS ARE IN MM. DECIMAL MARKER IS A PERIOD			TITLE PLUG MODULE ASSEMBLY NEXLEV CONNECTOR
CUSTOMER USE DRAWING			PART NO. SEE TABLE 1 REV N/A
CODE IDENT 31413			DRAWING NO. C-471-1025-500 REV N
			Pro/E type: P1002-PD-SHRD-CU-W-CAP Pro/E DRAWING: C-471-1025-500 1.5 M.1
SIZE B	SCALE 2/1	SHEET 1 OF 8	

DRW NO.
C-471-1025-500

SH
1
REV
N

4

3

DRW NO. C-471-1025-500	SH 2	REV N
---------------------------	---------	----------

ZONE	REV	SCR NUMBER	DESCRIPTION	BY	DATE	APPROVED
			SEE SHEET 1			

TABLE 1

PART NUMBER (SEE TABLE 2)	DESCRIPTION	WAFERS INSTALLED	H	J	N	P	S
471-1025-X00	10 POS. 2.5 HIGH. PLUG ASSY	ALL	2.5	8.5	9	15.75	21.82
471-1025-X02	10 POS. 2.5 HIGH. PLUG ASSY	1,3,5,7,9	2.5	8.5	9	15.75	21.82
471-2025-X00	20 POS. 2.5 HIGH. PLUG ASSY	ALL	2.5	8.5	19	33.25	39.32
471-2025-X01	20 POS. 2.5 HIGH. PLUG ASSY	1,3,5,7,9,11,13,15,17,19	2.5	8.5	19	33.25	39.32
471-2025-X02	20 POS. 2.5 HIGH. PLUG ASSY	1,3,5,7,9,11,13,14,15,16,17,18,19,20	2.5	8.5	19	33.25	39.32
471-2025-X03	20 POS. 2.5 HIGH. PLUG ASSY	1,2,4,5,7,8,10,11,13,14,16,17,19,20	2.5	8.5	19	33.25	39.32
471-2025-X04	20 POS. 2.5 HIGH. PLUG ASSY	1 THRU 16, 18, 20	2.5	8.5	19	33.25	39.32
471-3025-X00	30 POS. 2.5 HIGH. PLUG ASSY	ALL	2.5	8.5	29	50.75	56.82
471-3025-X01	30 POS. 2.5 HIGH. PLUG ASSY	1,3,5,7,9,11,13,15,17,19,21,23,25,27,29	2.5	8.5	29	50.75	56.82
471-1045-X00	10 POS. 4.5 HIGH. PLUG ASSY	ALL	4.5	10.5	9	15.75	21.82
471-1045-X01	10 POS. 4.5 HIGH. PLUG ASSY	1,3,5,7,9	4.5	10.5	9	15.75	21.82
471-1045-X02	10 POS. 4.5 HIGH. PLUG ASSY	1,2,3,4,5,6,8,10	4.5	10.5	9	15.75	21.82
471-1045-X03	10 POS. 4.5 HIGH. PLUG ASSY	1,3,5,7,9,10	4.5	10.5	9	15.75	21.82
471-1045-X04	10 POS. 4.5 HIGH. PLUG ASSY	1,2,3,4,6,7,8,9,10	4.5	10.5	9	15.75	21.82
471-2045-X00	20 POS. 4.5 HIGH. PLUG ASSY	ALL	4.5	10.5	19	33.25	39.32
471-2045-X01	20 POS. 4.5 HIGH. PLUG ASSY	1,3,5,7,9,11,13,15,17,19	4.5	10.5	19	33.25	39.32
471-2045-X02	20 POS. 4.5 HIGH. PLUG ASSY	1 THRU 16, 18, 20	4.5	10.5	19	33.25	39.32
471-2045-X03	20 POS. 4.5 HIGH. PLUG ASSY	1,2,3,4,5,6,7,8,9,10,11,12,13,14,16,18	4.5	10.5	19	33.25	39.32
471-3045-X00	30 POS. 4.5 HIGH. PLUG ASSY	ALL	4.5	10.5	29	50.75	56.82
471-3045-X01	30 POS. 4.5 HIGH. PLUG ASSY	1 THRU 26, 28, 30	4.5	10.5	29	50.75	56.82
471-1065-X00	10 POS. 6.5 HIGH. PLUG ASSY	ALL	6.5	12.5	9	15.75	21.82
471-1065-X01	10 POS. 6.5 HIGH. PLUG ASSY	1,3,5,7,9	6.5	12.5	9	15.75	21.82
471-2065-X00	20 POS. 6.5 HIGH. PLUG ASSY	ALL	6.5	12.5	19	33.25	39.32
471-2065-X01	20 POS. 6.5 HIGH. PLUG ASSY	1 THRU 16,18,20	6.5	12.5	19	33.25	39.32
471-2065-X02	20 POS. 6.5 HIGH. PLUG ASSY	1,3,5,7,9,11,13,14,15,16,17,18,19,20	6.5	12.5	19	33.25	39.32
471-3065-X00	30 POS. 6.5 HIGH. PLUG ASSY	ALL	6.5	12.5	29	50.75	56.82
471-3065-X01	30 POS. 6.5 HIGH. PLUG ASSY	1,3,5,7,9,11,13,15,17,19,21,23,25,27,29	6.5	12.5	29	50.75	56.82
471-5065-X00	25 POS. 6.5 HIGH. PLUG ASSY	ALL	6.5	12.5	24	42.00	48.07
471-2095-X00	20 POS. 9.5 HIGH. PLUG ASSY	ALL	9.5	15.5	19	33.25	39.32
471-2095-X01	20 POS. 9.5 HIGH. PLUG ASSY	1 THROUGH 12,18,19,20	9.5	15.5	19	33.25	39.32
471-3095-X00	30 POS. 9.5 HIGH. PLUG ASSY	ALL	9.5	15.5	29	50.75	56.82
471-5095-X00	25 POS. 9.5 HIGH. PLUG ASSY	ALL	9.5	15.5	24	42.00	48.07
471-5095-X01	25 POS. 9.5 HIGH. PLUG ASSY	1 THROUGH 21, 23, 25	9.5	15.5	24	42.00	48.07

TABLE 2

PART NUMBER	SOLDER BALL/WAFER DESCRIPTION
471-YYY5-10Y	TIN/LEAD SOLDER BALLS - EUTECTIC (RoHS 5 COMPLIANCE), WAFERS WITH Ni SULFAMATE UNDERPLATE
471-YYY5-20Y	TIN/LEAD SOLDER BALLS - EUTECTIC (RoHS 5 COMPLIANCE), WAFERS WITH NANO Ni UNDERPLATE
471-YYY5-60Y	LEAD FREE SOLDER BALLS (RoHS 6 COMPLIANCE), WAFERS WITH Ni SULFAMATE UNDERPLATE
471-YYY5-70Y	LEAD FREE SOLDER BALLS (RoHS 6 COMPLIANCE), WAFERS WITH NANO Ni UNDERPLATE

B

B

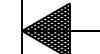

A

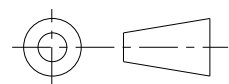
TOLERANCES		DESIGN 7/7/99 D. MCNAMARA	Amphenol TCS A Division of Amphenol Corporation 200 Innovative Way, Nashua, NH 03062 603.879.3000
0.0	±0.25	DRAWN 2/10/00 RJ MCISAAC	
0.00	±0.13	CHK 06/21/02 J.MARVIN	
0.000	± -	APVD 2/6/04 J.MARVIN	
ANGLES	± -		TITLE PLUG MODULE ASSEMBLY NEXLEV CONNECTOR
UNLESS OTHERWISE SPECIFIED DIMENSIONS ARE IN MM. DECIMAL MARKER IS A PERIOD			PART NO. SEE TABLE 1 REV N/A
 INTERPRET PER ASME Y14.5M CODE IDENT 31413			DRAWING NO. C-471-1025-500 REV N
			Pro/E type: P1002-PD-SHRD-CU-W-CAP Pro/E DRAWING: C-471-1025-500 1.5 M.1
SIZE B	SCALE 2/1	SHEET 2 OF 8	

CUSTOMER USE DRAWING

DRW NO. C-471-1025-500

SH 2 REV N

4

3

2

1

DRW NO. C-471-1025-500 SH 3 REV N

ZONE	REV	SCR NUMBER	DESCRIPTION	BY	DATE	APPROVED
			SEE SHEET 1			

PART NO. 471-0001-074
(PLUG VACUUM CAP-
REMOVE AFTER ASSY TO PCB)
(14.00) PICK-UP AREA

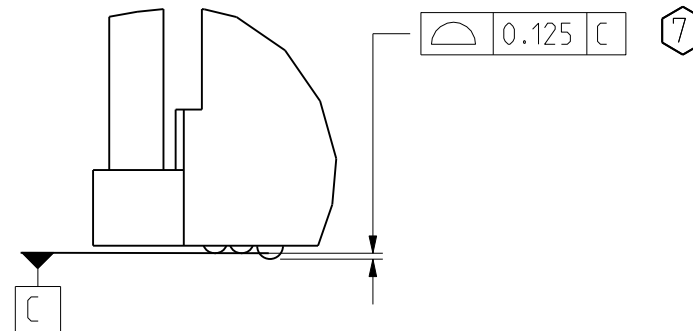
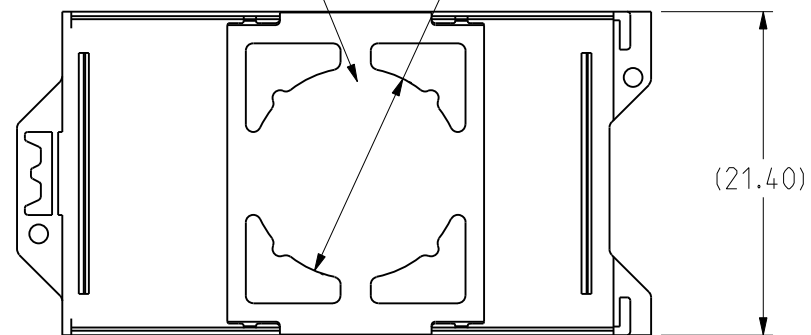

DETAIL B
SCALE 4/1

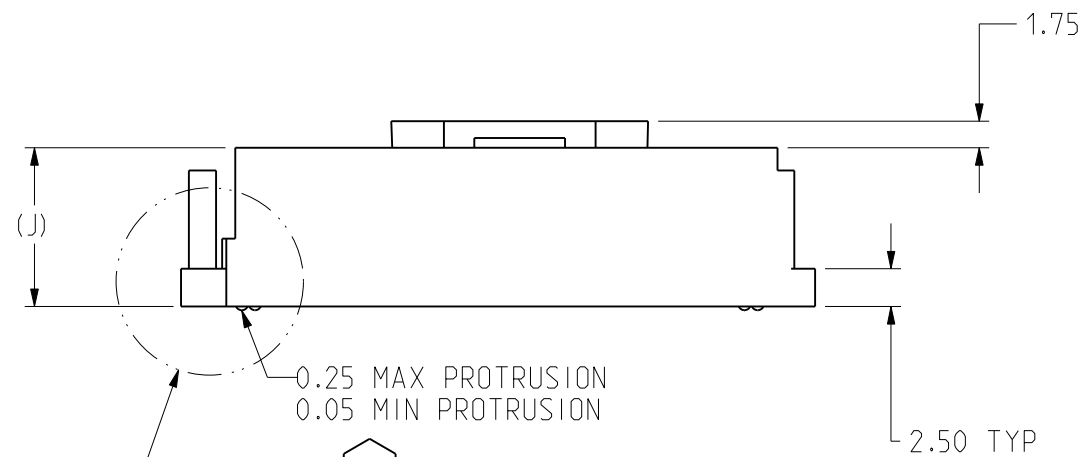

SEE DETAIL B

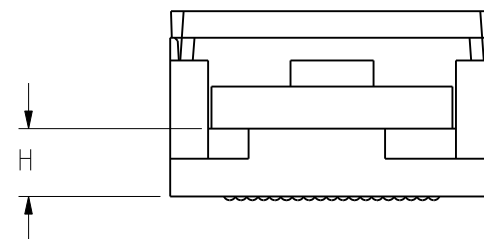

TOLERANCES		DESIGN 7/7/99 D. MCNAMARA
0.0	±0.25	DRAWN 2/10/00 RJ MCISAAC
0.00	±0.13	CHK 06/21/02 J.MARVIN
0.000	± -	APVD 2/6/04 J.MARVIN
ANGLES	± -	

Amphenol TCS A Division of Amphenol Corporation 200 Innovative Way, Nashua, NH 03062 603.879.3000		SH	3
		REV	N
TITLE		PLUG MODULE ASSEMBLY NEXLEV CONNECTOR	
PART NO.	SEE TABLE 1	REV	N/A
DRAWING NO.	C-471-1025-500	REV	N
Pro/E type: P1002-PD-SHRD-CU-W-CAP Pro/E DRAWING: C-471-1025-500		1.5	M.1
SIZE	B	SCALE	2/1
		SHEET 3 OF 8	

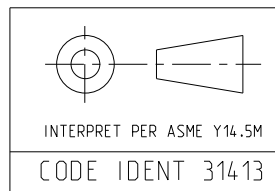

UNLESS OTHERWISE SPECIFIED DIMENSIONS
ARE IN MM. DECIMAL MARKER IS A PERIOD

CUSTOMER USE
DRAWING

DRW NO. C-471-1025-500

SH 3
REV N

4

3

4

3

2

1

B

B

A

ZONE	REV	SCR NUMBER	DESCRIPTION	BY	DATE	APPROVED
			SEE SHEET 1			

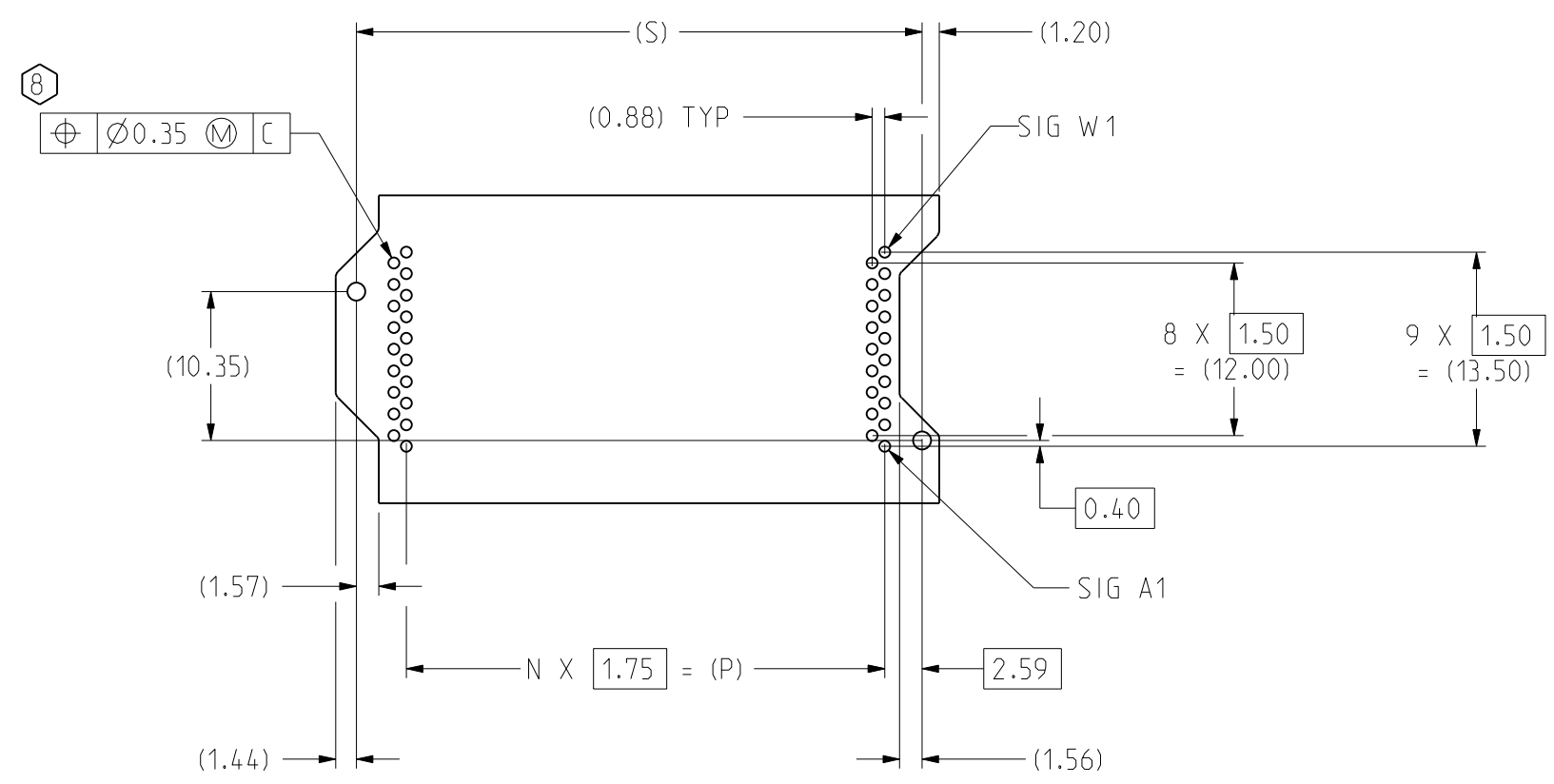

BOTTOM VIEW OF CONNECTOR

TOLERANCES		DESIGN 7/7/99 D. MCNAMARA
0.0	±0.25	DRAWN 2/10/00 RJ MCISAAC
0.00	±0.13	CHK 06/21/02 J.MARVIN
0.000	± -	APVD 2/6/04 J.MARVIN
ANGLES	± -	

Amphenol TCS A Division of Amphenol Corporation 200 Innovative Way, Nashua, NH 03062 603.879.3000		TITLE	PLUG MODULE ASSEMBLY NEXLEV CONNECTOR
		PART NO.	SEE TABLE 1
REV	N/A	DRAWING NO.	C-471-1025-500
Pro/E type:	P1002-PD-SHRD-CU-W-CAP	REV	N
Pro/E DRAWING:	C-471-1025-500	SCALE	1.5 M.1
SIZE	B	SHEET	4 OF 8

UNLESS OTHERWISE SPECIFIED DIMENSIONS ARE IN MM. DECIMAL MARKER IS A PERIOD

INTERPRET PER ASME Y14.5M
CODE IDENT 31413

CUSTOMER USE
DRAWING

DRW NO.
C-471-1025-500

SH	4
REV	N

DRW NO. C-471-1025-500	SH 5	REV N
---------------------------	---------	----------

ZONE	REV	SCR NUMBER	DESCRIPTION	BY	DATE	APPROVED
			SEE SHEET 1			

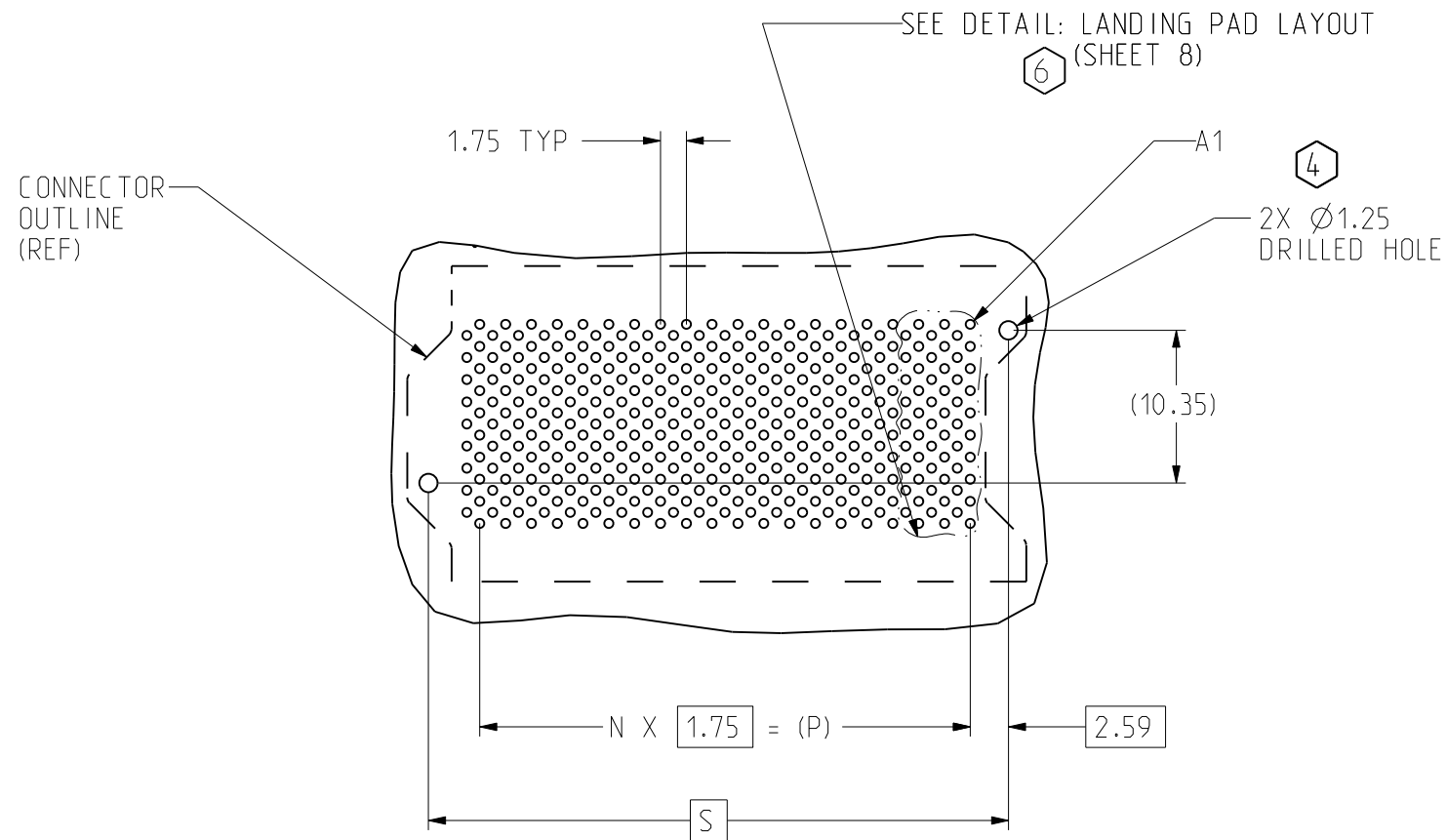

PCB LANDING PAD LAYOUT
CONNECTOR SIDE

TOLERANCES		DESIGN 7/7/99 D. MCNAMARA
0.0	±0.25	DRAWN 2/10/00 RJ MCISAAC
0.00	±0.13	CHK 06/21/02 J.MARVIN
0.000	± -	APVD 2/6/04 J.MARVIN
ANGLES	± -	

Amphenol TCS A Division of Amphenol Corporation 200 Innovative Way, Nashua, NH 03062 603.879.3000		TITLE	PLUG MODULE ASSEMBLY NEXLEV CONNECTOR
		PART NO.	SEE TABLE 1
REV	N/A	DRAWING NO.	C-471-1025-500
Pro/E type:	P1002-PD-SHRD-CU-W-CAP	REV	N
Pro/E DRAWING:	C-471-1025-500	1.5	M.1
SIZE	B	SCALE	2/1
		SHEET 5 OF 8	

INTERPRET PER ASME Y14.5M
 CODE IDENT 31413

UNLESS OTHERWISE SPECIFIED DIMENSIONS ARE IN MM. DECIMAL MARKER IS A PERIOD

**CUSTOMER USE
DRAWING**

DRW NO.
C-471-1025-500

SH
5

REV
N

4

3

DRW NO. C-471-1025-500	SH 6	REV N
---------------------------	---------	----------

ZONE	REV	SCR NUMBER	DESCRIPTION	BY	DATE	APPROVED
			SEE SHEET 1			

B

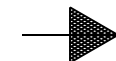

A

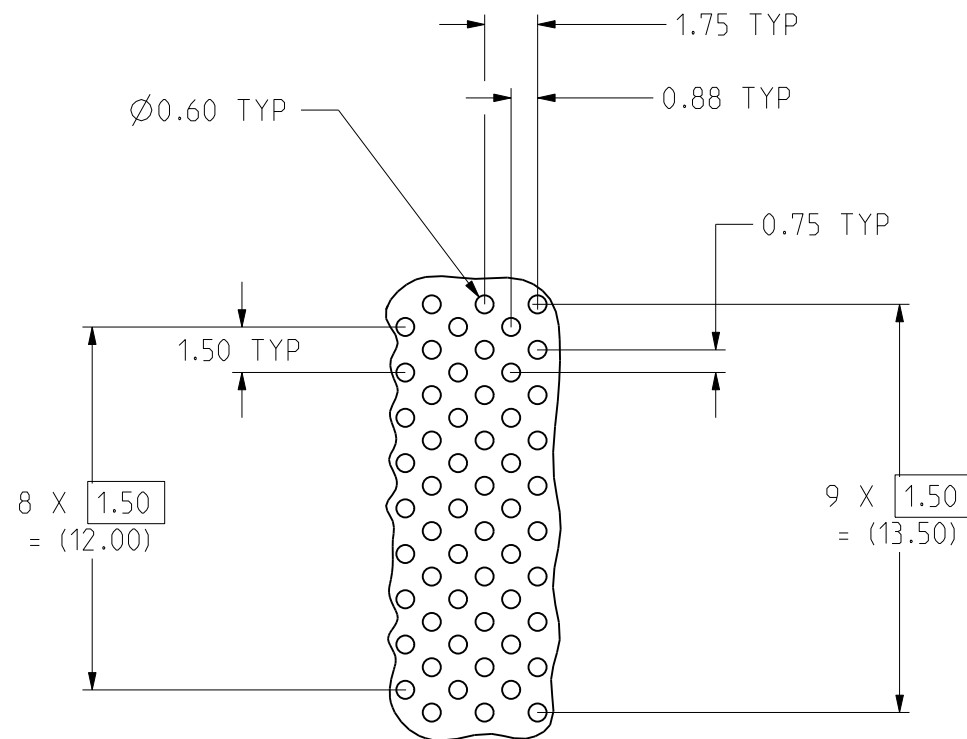

DETAIL: LANDING PAD LAYOUT
 NOTE: SEE TECHNICAL BULLETIN TB-2082
 FOR LANDING PAD SHAPE, MASKING, ROUTING
 AND OTHER DETAILS
 SCALE 4/1

B



DRW NO.
C-471-1025-500

SH
6
REV
N

TOLERANCES		DESIGN 7/7/99 D. MCNAMARA
0.0	± 0.25	DRAWN 2/10/00 RJ MCISAAC
0.00	± 0.13	CHK 06/21/02 J.MARVIN
0.000	$\pm -$	APVD 2/6/04 J.MARVIN
ANGLES	$\pm -$	

Amphenol TCS A Division of Amphenol Corporation 200 Innovative Way, Nashua, NH 03062 603.879.3000		TITLE	PLUG MODULE ASSEMBLY NEXLEV CONNECTOR
		PART NO.	SEE TABLE 1
REV	N/A	DRAWING NO.	C-471-1025-500
Pro/E type:	P1002-PD-SHRD-CU-W-CAP	REV	N
Pro/E DRAWING:	C-471-1025-500	1.5	M.1
SIZE	B	SCALE	2/1
		SHEET 6 OF 8	

INTERPRET PER ASME Y14.5M
 CODE IDENT 31413

UNLESS OTHERWISE SPECIFIED DIMENSIONS ARE IN MM. DECIMAL MARKER IS A PERIOD

CUSTOMER USE DRAWING

4

3

2

1



DRW NO. C-471-1025-500	SH 7	REV N
---------------------------	---------	----------

ZONE	REV	SCR NUMBER	DESCRIPTION	BY	DATE	APPROVED
			SEE SHEET 1			

6 5 5 5 5 5 5 5 5 5 4 4 4 4 4 4 4 4 4 4 3 3 3 3 3 3 3 3 2 2 2 2 2 2 2 2 1 1 1 1 1 1 1 1 1 1 1 1 1 1 1
0 9 8 7 6 5 4 3 2 1 0 9 8 7 6 5 4 3 2 1 0 9 8 7 6 5 4 3 2 1 0 9 8 7 6 5 4 3 2 1 0 9 8 7 6 5 4 3 2 1

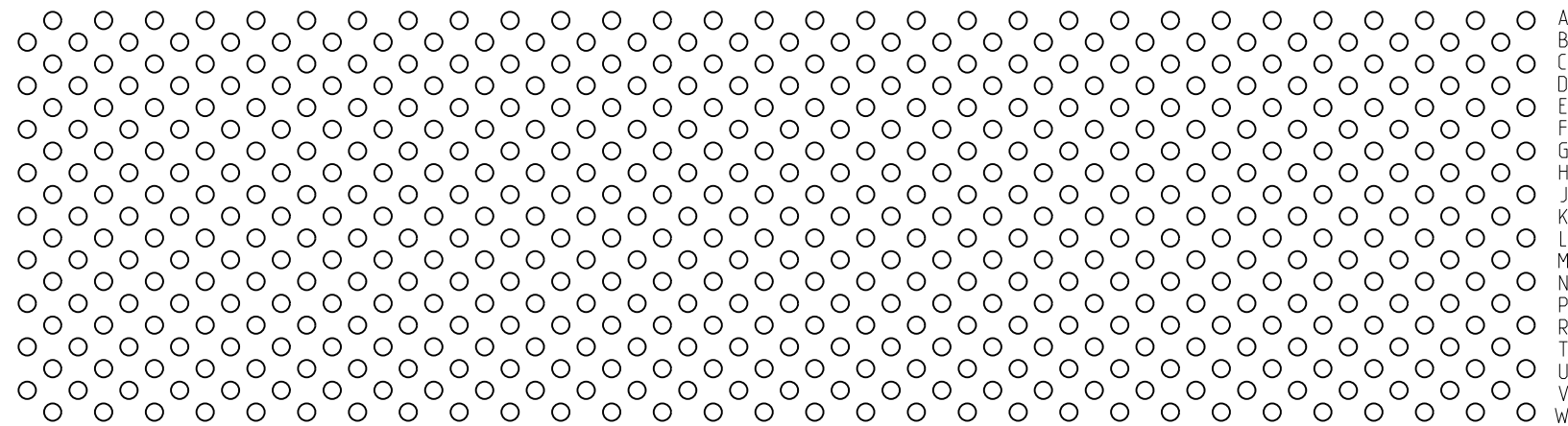

300 SIGNAL PINS. 270 PWR/GND 30 WAFERS	250 SIGNAL PINS. 225 PWR/GND 25 WAFERS	200 SIGNAL PINS. 180 PWR/GND 20 WAFERS	100 SIGNAL PINS. 90 PWR/GND 10 WAFERS
---	---	---	--

CONNECTOR SIDE OF PCB
PIN ASSIGNMENT
SCALE 4/1

TOLERANCES		DESIGN 7/7/99 D. MCNAMARA
0.0	±0.25	DRAWN 2/10/00 RJ MCISAAC
0.00	±0.13	CHK 06/21/02 J.MARVIN
0.000	± -	APVD 2/6/04 J.MARVIN
ANGLES	± -	

Amphenol TCS A Division of Amphenol Corporation 200 Innovative Way, Nashua, NH 03062 603.879.3000		TITLE PLUG MODULE ASSEMBLY NEXLEV CONNECTOR
		PART NO. SEE TABLE 1
DRAWING NO. C-471-1025-500		REV N
Pro/E type: P1002-PD-SHRD-CU-W-CAP Pro/E DRAWING: C-471-1025-500		1.5 M.1
SIZE B	SCALE 2/1	SHEET 7 OF 8

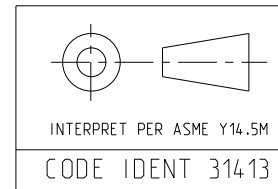

UNLESS OTHERWISE SPECIFIED DIMENSIONS
ARE IN MM. DECIMAL MARKER IS A PERIOD

**CUSTOMER USE
DRAWING**

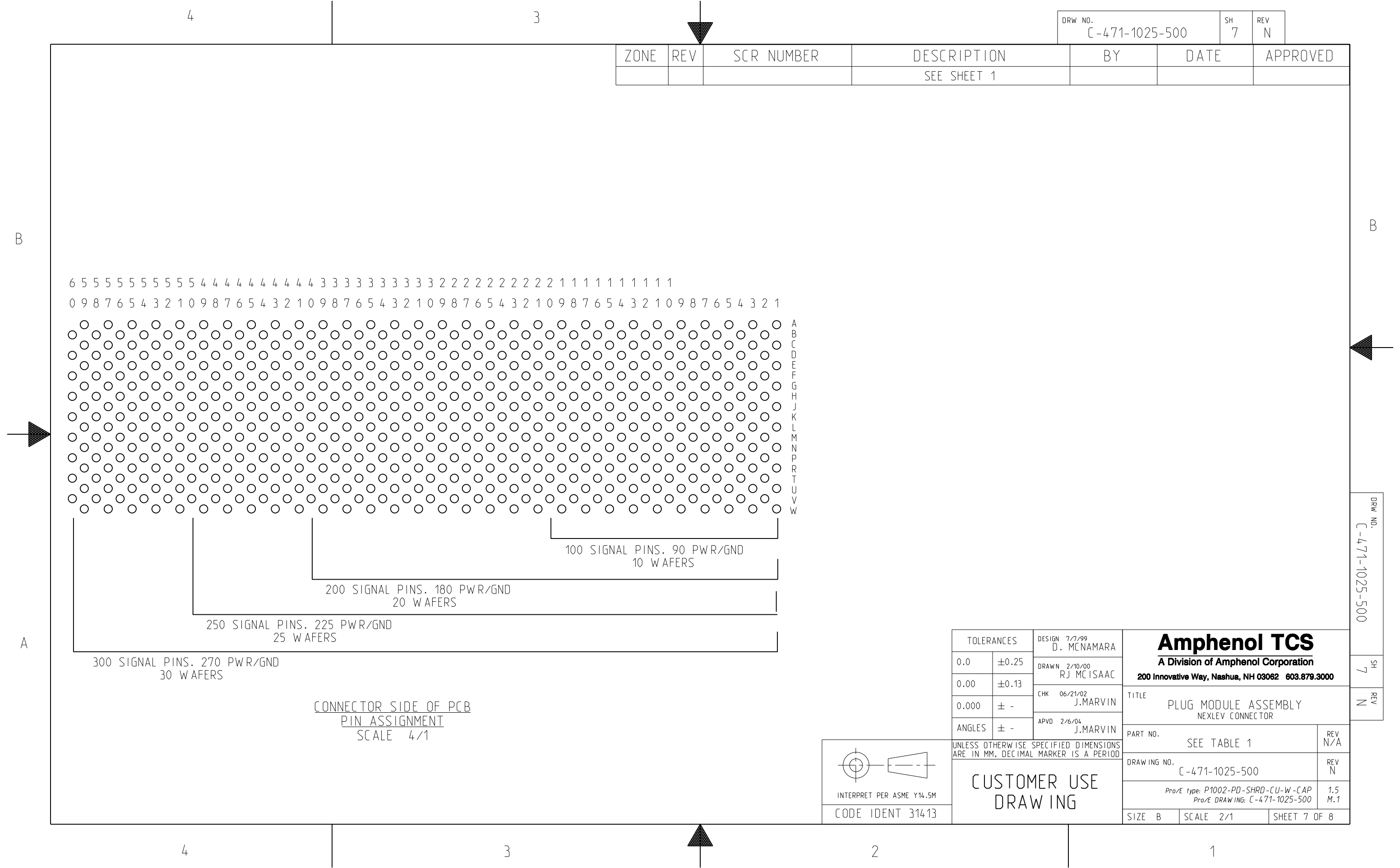

DRW NO. C-471-1025-500	SH 8	REV N
---------------------------	---------	----------

ZONE	REV	SCR NUMBER	DESCRIPTION	BY	DATE	APPROVED
			SEE SHEET 1			

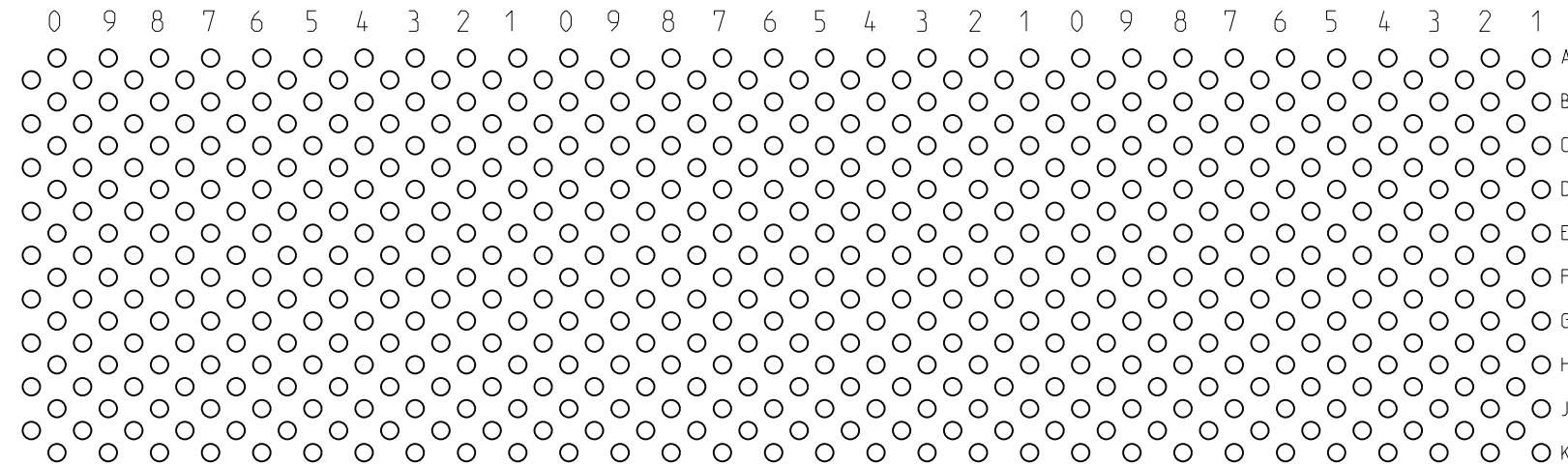

100 SIGNAL PINS. 90 PWR/GND
10 WAFERS

200 SIGNAL PINS. 180 PWR/GND
20 WAFERS

250 SIGNAL PINS. 225 PWR/GND
25 WAFERS

300 SIGNAL PINS. 270 PWR/GND
30 WAFERS

ALTERNATE PIN NUMBERING
(CONNECTOR SIDE OF PCB)
SCALE 4/1

TOLERANCES		DESIGN 7/7/99 D. MCNAMARA
0.0	±0.25	DRAWN 2/10/00 RJ MCISAAC
0.00	±0.13	CHK 06/21/02 J.MARVIN
0.000	± -	APVD 2/6/04 J.MARVIN
ANGLES	± -	

Amphenol TCS A Division of Amphenol Corporation 200 Innovative Way, Nashua, NH 03062 603.879.3000		TITLE	PLUG MODULE ASSEMBLY NEXLEV CONNECTOR
		PART NO.	SEE TABLE 1
REV	N/A	DRAWING NO.	C-471-1025-500
Pro/E type:	P1002-PD-SHRD-CU-W-CAP	REV	N
Pro/E DRAWING:	C-471-1025-500	1.5	M.1
SIZE	B	SCALE	2/1
		SHEET	8 OF 8

INTERPRET PER ASME Y14.5M
 CODE IDENT 31413

UNLESS OTHERWISE SPECIFIED DIMENSIONS
ARE IN MM. DECIMAL MARKER IS A PERIOD

**CUSTOMER USE
DRAWING**

DRW NO.
C-471-1025-500

SH
8
REV
N



4

3

4

3

2

1

B

B

A