

3SK195

SILICON N CHANNEL DUAL GATE MOS TYPE FIELD EFFECT TRANSISTOR

TV TUNER, VHF RF AMPLIFIER APPLICATIONS.
FM TUNER APPLICATIONS.

- Superior Cross Modulation Performance.
- Low Reverse Transfer Capacitance : $C_{rss} = 0.015\text{pF}$ (Typ.)
- Low Noise Figure : $NF = 1.1\text{dB}$ (Typ.)

MAXIMUM RATINGS ($T_a = 25^\circ\text{C}$)

CHARACTERISTIC	SYMBOL	RATING	UNIT
Drain-Source Voltage	V_{DS}	13.5	V
Gate 1-Source Voltage	V_{G1S}	± 8	V
Gate 2-Source Voltage	V_{G2S}	± 8	V
Drain Current	I_D	30	mA
Drain Power Dissipation	P_D	150	mW
Channel Temperature	T_{ch}	125	$^\circ\text{C}$
Storage Temperature Range	T_{stg}	$-55 \sim 125$	$^\circ\text{C}$

Marking

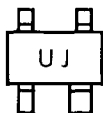

ELECTRICAL CHARACTERISTICS ($T_a = 25^\circ\text{C}$)

CHARACTERISTIC	SYMBOL	TEST CONDITION	MIN.	TYP.	MAX.	UNIT
Gate 1 Leakage Current	I_{G1SS}	$V_{DS} = 0, V_{G1S} = \pm 4\text{V}, V_{G2S} = 0$	—	—	± 50	nA
Gate 2 Leakage Current	I_{G2SS}	$V_{DS} = 0, V_{G1S} = 0, V_{G2S} = \pm 4\text{V}$	—	—	± 50	nA
Drain-Source Voltage	$V_{(BR)DSX}$	$V_{G1S} = -4\text{V}, V_{G2S} = -4\text{V}, I_D = 100\mu\text{A}$	13.5	—	—	V
Drain Current	I_{DSS}	$V_{DS} = 6\text{V}, V_{G1S} = 0, V_{G2S} = 4\text{V}$	0	—	0.1	mA
Gate 1-Source Cut-off Voltage	$V_{G1S(OFF)}$	$V_{DS} = 6\text{V}, V_{G2S} = 4\text{V}, I_D = 100\mu\text{A}$	0	—	1.0	V
Gate 2-Source Cut-off Voltage	$V_{G2S(OFF)}$	$V_{DS} = 6\text{V}, V_{G1S} = 4\text{V}, I_D = 100\mu\text{A}$	0	—	1.2	V
Forward Transfer Admittance	$ Y_{fs} $	$V_{DS} = 6\text{V}, V_{G2S} = 4\text{V}, I_D = 10\text{mA}, f = 1\text{kHz}$	—	13	—	mS
Input Capacitance	C_{iss}	$V_{DS} = 6\text{V}, V_{G2S} = 4\text{V}, I_D = 10\text{mA}, f = 1\text{MHz}$	2.0	2.7	3.4	pF
Reverse Transfer Capacitance	C_{rss}	$I_D = 10\text{mA}, f = 1\text{MHz}$	—	0.015	0.03	pF
Power Gain	G_{ps}	$V_{DS} = 6\text{V}, V_{G2S} = 4\text{V}, I_D = 10\text{mA}, f = 200\text{MHz}$ (Fig.1)	22	27	—	dB
Noise Figure	NF		—	1.1	2.2	dB

Unit in mm

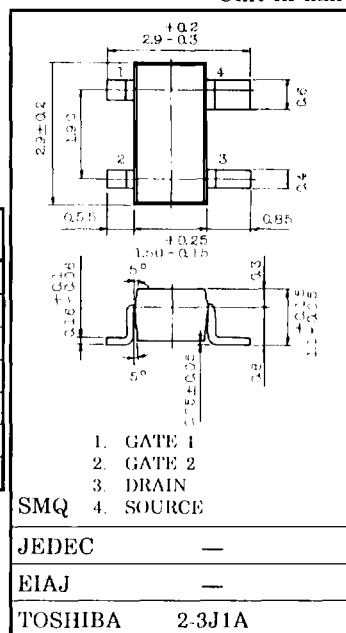

Weight : 0.013g

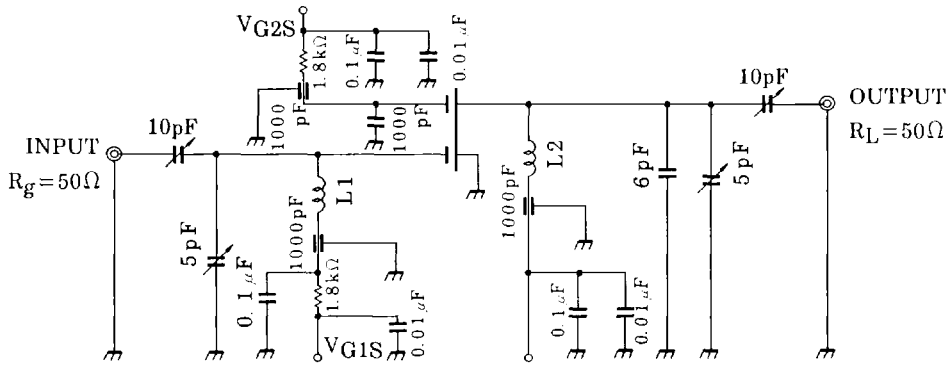

L1 : 1mmϕ Silver Plated Copper Wire, 2 Turns, 8mm ID
 L2 : 1mmϕ Silver Plated Copper Wire, 2.5 Turns, 8mm ID

Fig.1 200MHz, Gps NF TEST CIRCUIT

