

NOTES:

1. MATERIALS AND FINISHES:
 BODY - BRASS, NICKEL PLATING
 CONTACT - BRASS, SILVER PLATING
 INSULATOR - PTFE
2. ELECTRICAL:
 A. IMPEDANCE: 50 OHM
 B. FREQUENCY RANGE: DC 0-4 GHz
 C. DIELECTRIC WITHSTANDING VOLTAGE: 1500 VRMS, MIN.
3. MECHANICAL:
 A. DURABILITY: 500 CYCLES MIN.
 B. TEMPERATURE RANGE: - 65°C to +165°C
4. WHEN CRIMPING CONTACT PIN TO CABLE, CRIMP WITH AMPHENOL TOOL 227-944 (M22520/5-01) AND DIE SET 227-1221-11, CAVITY 'B' (M22520/5-11, CLOSURE 'B')
5. WHEN CRIMPING FERRULE TO CABLE, CRIMP WITH AMPHENOL TOOL 227-944 (M22520/5-01) AND DIE SET 227-1221-11, CAVITY 'A' (M22520/5-11, CLOSURE 'A')
6. FOR ASSEMBLY INSTRUCTIONS SEE AMPHENOL SPEC.349-50229

THIRD ANGLE PROJ.

REVISIONS

REV	DESCRIPTION	DATE	ECO	APPR
B	SEE SHEET 1	10-Mar-08	--	AW
R	REDRAWN TO UPDATE FORMAT	11-Dec-08	47239	SH
T	SEE SHEET 1	12-Jan-10	47921	SH

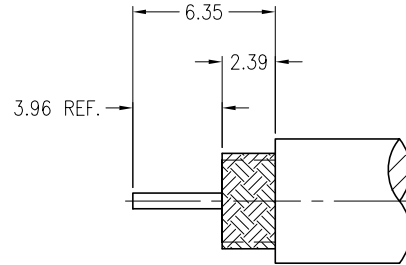

RECOMMENDED
CABLE STRIPPING DIM'S

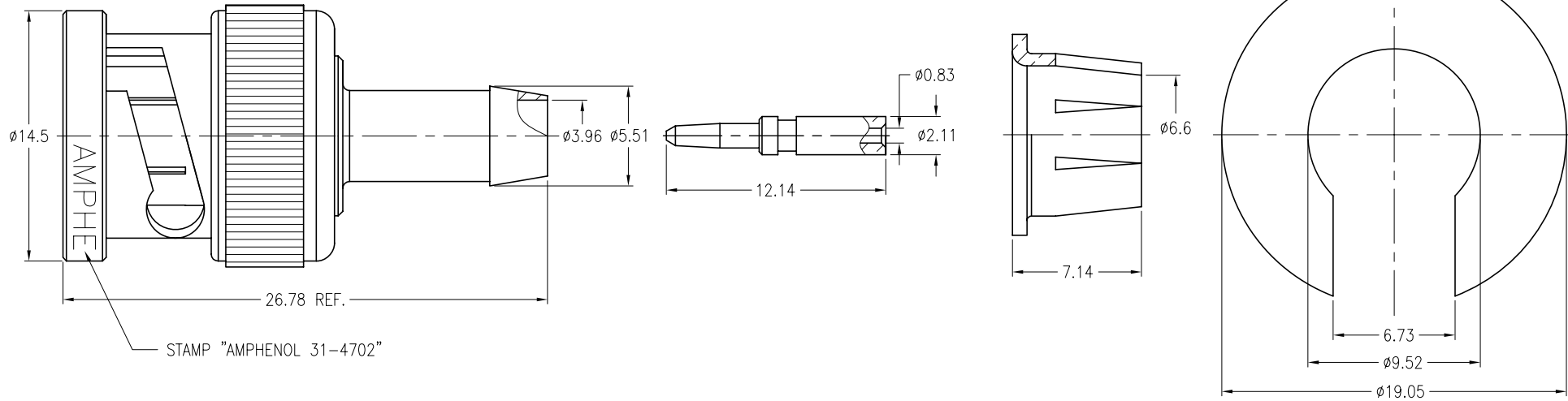

THIS CONNECTOR IS COVERED BY U.S. PATENT 3439294 & 4053200

CUSTOMER OUTLINE DRAWING

ALL OTHER SHEETS ARE FOR INTERNAL USE ONLY

UNLESS OTHERWISE SPECIFIED, DIMENSIONS ARE IN METRIC AND TOLERANCES ARE:
 <0.5mm ±0.05mm 0.5 - 6mm ±0.1mm 6 - 30mm ±0.2mm 30 - 120mm ±0.3mm ANGLES ±1°

NOTICE - These drawings, specifications, or other data (1) are, and remain the property of Amphenol Corp. (2) must be returned upon request; and (3) are confidential and not to be disclosed to any person other than those to whom they are given by Amphenol Corp. The furnishing of these drawings, specifications, or other data by Amphenol Corp., or to any other person to anyone for any purpose is not to be regarded by implication or otherwise in any manner licensing, granting rights or permitting such holder or any other person to manufacture, use or sell any product, process or design, patented or otherwise, that may in any way be related to or disclosed by said drawings, specifications, or other data.

MATERIAL	DRAWN	T.DENG	DATE	11-Jan-10	TITLE			Amphenol RF Danbury CT USA, Tainan Taiwan, Shenzhen China www.amphenolrf.com	
	ENGINEER	C.WANG	DATE	11-Jan-10					
REFERENCE	APPROVED	S.HSIEH	DATE	12-Jan-10	BNC/FCP PLUG (FOR RG-59/U TYPE CABLE)			DRAWING NO. 31-4702	
	CAD FILE	F:\DWG\CNPD\31\4702-TSZ						SCALE: 3/1	SHEET 2 OF 2
FINISH					DWG SIZE	CODE ID	REV	PART NO. 31-4702	
				B		74868	T		