

# 75 Ω SMB Style Coaxial Connector

## 27CP Series

DDK Ltd.

### FEATURE

- 27CP series is a SMB connector which corresponding to 75 Ω .
- Low profile coaxial connector with push on lock mechanism. It is suitable to the applications of internal equipments.
- Push-on locking mechanism provides quick and reliable connection.
- Incompatible to 27DPseries(50 Ω SMB connector)

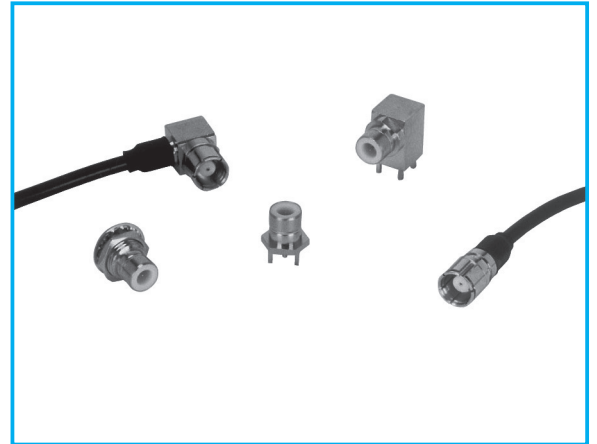

Frequency Range

DC to 500MHz

Characteristic Impedance

75 Ω

Lock Type

Push On

### APPLICATIONS

Measurement equipments, Broadcasting, CATV, HDTV

### SPECIFICATIONS

Characteristic Impedance	75 Ω
Rated Voltage	500VAC(r.m.s.)
Dielectric Withstanding Voltage	1000V AC(r.m.s.)for1 minute
Insulation Resistance	1000M Ω Mim. at 500V DC
Contact Resistance	6m Ω Max.
V.S.W.R.	1.5 max. at DC to 500MHz
Operating Temperature	-40 ~ +85°C

\* The specifications are typical but may not apply to all connectors. Please check the specifications on each item with its drawing from us when you use.

### MATERIAL/FINISH



Item	Material / Finish
Shell (Body)	Copper Alloy / Ni or Au Plating
Contact (Male)	Copper Alloy / Au Plating
Contact (Female)	Copper Alloy / Au Plating
Insulator	PTFE

© Please acknowledge that the specification etc. of this catalog might change by the improvement etc. without notice. Moreover, the characteristic and the specification of the published product are the reference values. Please confirm the content with the latest delivery specifications when you use the product.

▶ Straight Cable Plug

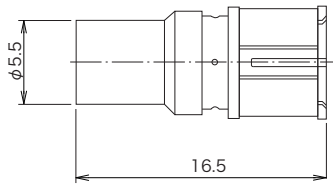

Part Number	Applicable Cable	Finish		Assembly Instruction	Crimp Tool
		Outer Conductor	Center Conductor		
27CP-P-1.5-CF	1.5C-2V	Ni	Au	1	CR-H-1100
27CP-P-1.5W-CF	1.5C-2W	Ni	Au		CR-H-1100
27CP-P-2.5-CF	2.5C-2V	Ni	Au	1	CR-H-1100

▶ Right Angle Cable Plug

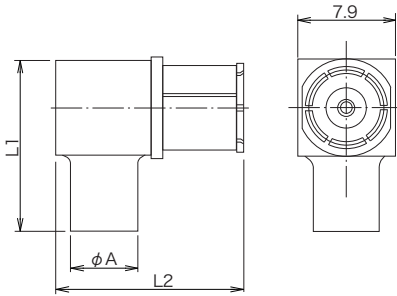

Part Number	Applicable Cable	phi A	L1	L2	Finish		Assembly Instruction	Crimp Tool
					Outer Conductor	Center Conductor		
27CP-LP-1.5-CF	1.5C-2V	5.5	14.40	15.5	Ni	Au	2	CR-H-1100
27CP-LP-1.5W-CF	1.5C-2W	5.5	14.35	15.5	Ni	Au		CR-H-1100
	1.5C-2WX							
27CP-LP-2.5W-CF	2.5C-2W	6.0	14.35	15.5	Ni	Au		CR-H-15285
27CP-LP-2.5-CF	2.5C-2V	5.5	14.40	15.5	Ni	Au	2	CR-H-1100

▶ Straight Bulkhead Cable Jack

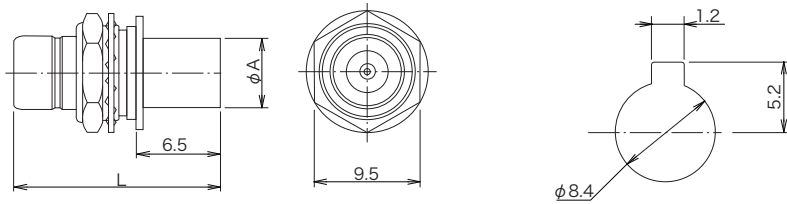

Mounting Panel Thickness : 2.4mm max.

Panel Mounting Dimensions

Part Number	Applicable Cable	phi A	L	Finish		Assembly Instruction	Crimp Tool
				Outer Conductor	Center Conductor		
27CP-BJ-1.5-CF	1.5C-2V	5.5	17.10	Ni	Au		CR-H-1100
27CP-BJ-1.5W-CF	1.5C-2W	5.5	17.07	Ni	Au	1	CR-H-1100
27CP-BJ-2.5-CF	2.5C-2V	5.5	17.10	Ni	Au		CR-H-1100
27CP-BJ-2.5W-CF	2.5C-2W	6.0	17.00	Ni	Au		CR-H-15285

▶ Straight Bulkhead Receptacle

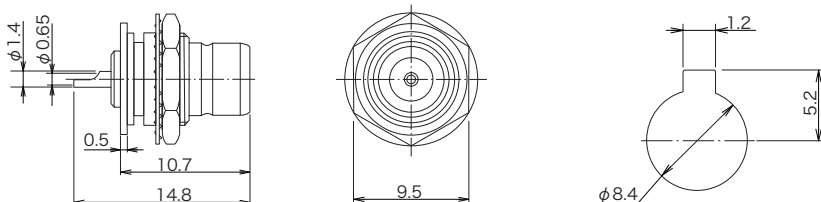

Mounting Panel Thickness : 2.4mm max.

Panel Mounting Dimensions

Part Number	Finish	
	Outer Conductor	Center Conductor
27CP-BR-CF	Ni	Au

© Please acknowledge that the specification etc. of this catalog might change by the improvement etc. without notice.

Moreover, the characteristic and the specification of the published product are the reference values.

Please confirm the content with the latest delivery specifications when you use the product.

▶ Right Angle Receptacle Jack

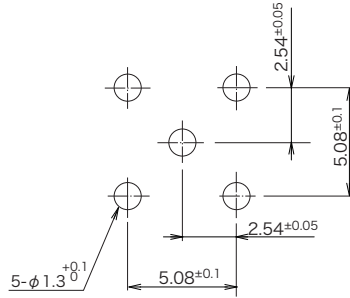
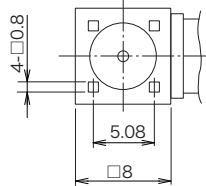
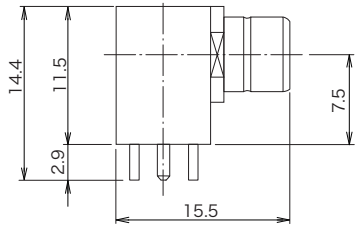

Panel Mounting Dimensions

Part Number	Finish	
	Outer Conductor	Center Conductor
27CP-LR-PC-CF	Ni	Au

▶ Receptacle Jack

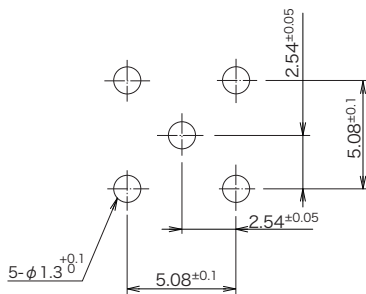
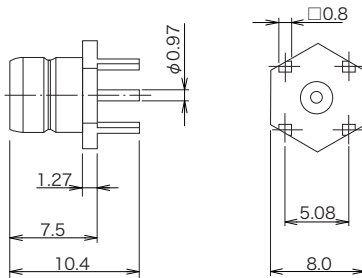

Panel Mounting Dimensions

Part Number	Finish	
	Outer Conductor	Center Conductor
27CP-R-PC-CF	Ni	Au

© Please acknowledge that the specification etc. of this catalog might change by the improvement etc. without notice.  
 Moreover, the characteristic and the specification of the published product are the reference values.  
 Please confirm the content with the latest delivery specifications when you use the product.

▶ Assembly Instruction (1)

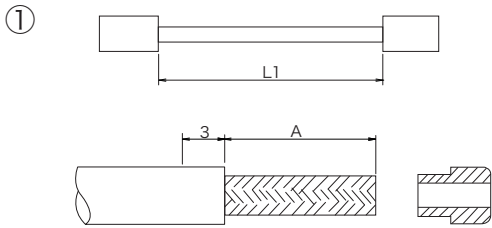

① Cut the cable as fig.1.

The cable length require for the cable assembly  
 $L=L1+A+3$

Part Number	A
27CP-P-1.5-CF	6.4mm
27CP-P-2.5-CF	6.4mm
27CP-BJ-1.5W-CF	8.0mm

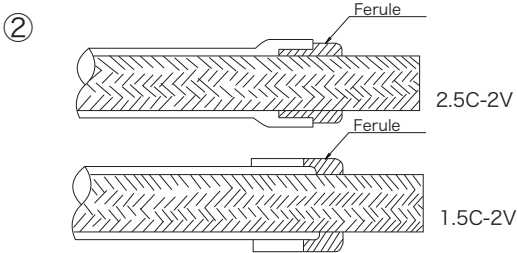

② Insert the ferule between outer conductor and sheath when the cable is 2.5C-2V.  
 Insert the ferule until ferule contacts with the sheath when the cable is 1.5C-2V.

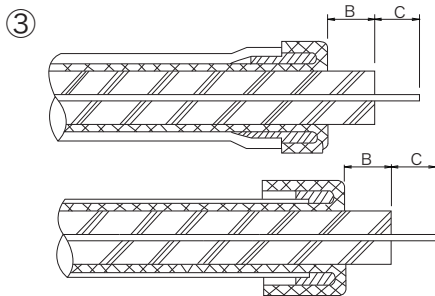

③ Pick the outer conductor and turn down to the ferule. Cut the extra outer conductor along the ferule. Cut the center conductor as fig.3.  
 Please be careful to not damage the center conductor. Pre-solder the center conductor.

Part Number	B	C
27CP-P-1.5-CF	2.0mm	1.6mm
27CP-P-2.5-CF	2.0mm	1.6mm
27CP-BJ-1.5W-CF	2.0mm	3.0mm

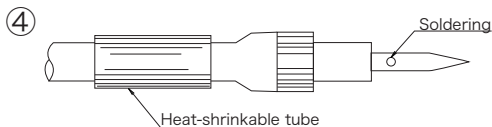

④ Insert the contact and solder from side hole. Please be careful to not make gap between contact and center conductor of the cable and not damage the insulator by heat. When the solder is stick out, please shave the extra solder along the contact. Insert the heat-shrinkable tube.

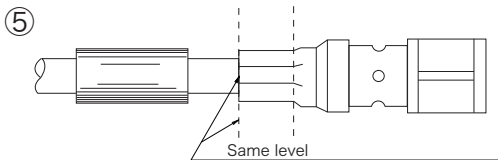

⑤ Insert the above contact into the body and crimp the root of the body as fig.5.

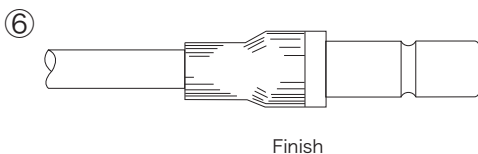

⑥ Cover the heat shrinkable tube on the root of the body and heat up.

© Please acknowledge that the specification etc. of this catalog might change by the improvement etc. without notice.  
 Moreover, the characteristic and the specification of the published product are the reference values.  
 Please confirm the content with the latest delivery specifications when you use the product.

## ▶ Assembly Instruction (2)

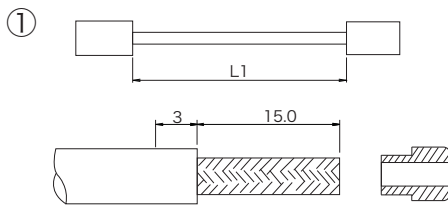

- ① Cut the cable as fig.1.  
The cable length require for the cable assembly  
 $L=L1+15+3$

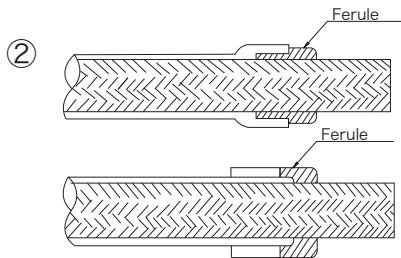

- ② Insert the ferule between outer conductor and sheath when the cable is 2.5C-2V.  
Insert the ferule until ferule contacts with the sheath when the cable is 1.5C-2V.

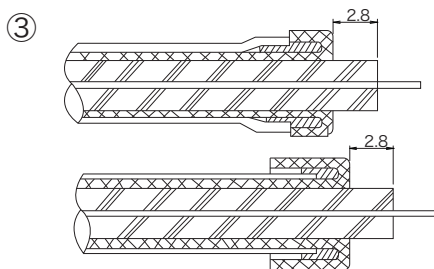

- ③ Pick the outer conductor and turn down to the ferule. Cut the extra outer conductor along the ferule. Cut the center conductor as fig.3.  
Please be careful to not damage the center conductor. Pre-solder the center conductor.

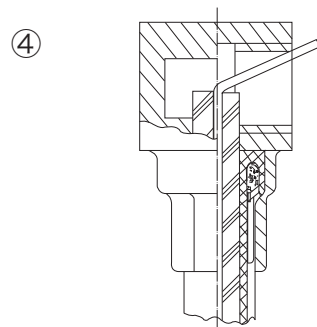

- ④ Insert the boot into the cable and insert the center conductor into the body as fig.4.  
Crimp the root of the body.

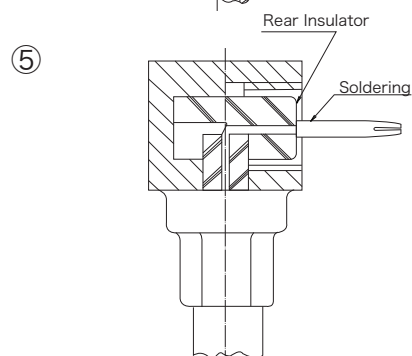

- ⑤ Insert the rear insulator into the center conductor.  
Cut the center conductor in 1.6mm and pre-soldering.  
Insert the contact and solder.

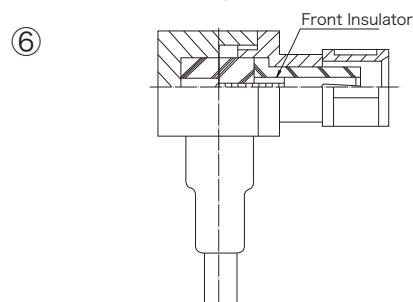

- ⑥ Insert the front insulator into the contact and twist in the interface.  
Cover the heat-shrinkable tube and heat up.

© Please acknowledge that the specification etc. of this catalog might change by the improvement etc. without notice.  
Moreover, the characteristic and the specification of the published product are the reference values.  
Please confirm the content with the latest delivery specifications when you use the product.