

ALSO
AVAILABLE IN
SURFACE
MOUNT

DESCRIPTION

The 1EZ110D5 thru 1EZ200D5 series of axial-leaded 1.0 watt Zeners provides voltage regulation selections with 5% tolerances from 110 to 200 volts in a DO-41 plastic package size. Other Zener voltage tolerances are also available by changing the suffix number to the tolerance desired such as 1 and 2 for tighter tolerances or 10 for wider tolerance. These plastic encapsulated Zeners have moisture classification of Level 1 with no dry pack required and are also available in various military equivalent screening levels by adding a prefix identifier as also described in the Features section. They may be operated at high maximum dc currents or full power rating with adequate heat sinking. Microsemi also offers numerous other Zener products to meet higher and lower power applications.

APPEARANCE

**DO-41 or
DO-204AL
(Plastic)**

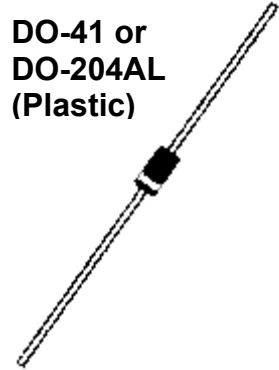

IMPORTANT: For the most current data, consult MICROSEMI's website: <http://www.microsemi.com>

FEATURES

- Higher voltages of 110 to 200 V extends the JEDEC registered 1N4728 thru 1N4664A (3.3 to 100 V)
- Standard voltage tolerances are plus/minus 5% with a "5" suffix and 10% with "10" suffix identification
- Tight tolerances available in plus or minus 2% or 1% with "2" or "1" suffix respectively
- Options for screening in accordance with MIL-PRF-19500 for JAN, JANTX, JANTXV, and JANS are available by adding MQ, MX, MV, or MSP prefixes respectively to part numbers
- Surface mount package equivalents available as SMBJ1EZ110D5 to SMBJ1EZ200D5 in the popular DO-214AA package, or SMBG1EZ110D5 to SMBG1EZ200D5 in the DO-215AA package

APPLICATIONS / BENEFITS

- Regulates voltage over a broad operating current and temperature range.
- Zener voltage selection from 110 to 200 V.
- Flexible axial-lead mounting terminals.
- Nonsensitive to ESD per MIL-STD-750 Method 1020
- Withstands surge stresses.
- High specified maximum current (I_{ZM}) when adequately heat sunk.
- Moisture classification is Level 1 per IPC/JEDEC J-STD-020B with no dry pack required.

MAXIMUM RATINGS

- Power dissipation at 25°C: 1.0 watts (also see derating in Figure 1).
- Operating and Storage temperature: -65°C to +150°C.
- Thermal Resistance: 45°C/W junction to lead at 3/8 (10mm) lead length from body, or 105°C/W junction to ambient when mounted on FR4 PC board (1oz Cu) with 4 mm² copper pads and track width 1 mm, length 25 mm.
- Steady-State Power: 1.0 watt at $T_L \leq 105^\circ\text{C}$ 3/8 inch (10 mm) from body, or 1.0 watts at $T_A \leq 45^\circ\text{C}$ when mounted on FR4 PC described for thermal resistance (also see Figure 1).
- Forward voltage @ 200 mA: 1.2 volts (maximum).
- Solder Temperatures: 260°C for 10 s (max).

MECHANICAL AND PACKAGING

- CASE: Void-free transfer molded thermosetting epoxy body meeting UL94V-0
- TERMINALS: Leads, tin-lead plated solderable per MIL-STD-750, method 2026
- POLARITY: Cathode indicated by band where diode is to be operated with the banded end positive with respect to the opposite end
- MARKING: Part number
- TAPE & REEL option: Standard per EIA-296 (add "TR" suffix to part number)
- WEIGHT: 0.4 grams
- See package dimensions on last page

ELECTRICAL CHARACTERISTICS @ 25°C

MICROSEMI PART NUMBER (Note 1 and 5)	NOMINAL ZENER VOLTAGE (Note 2)		MAXIMUM ZENER IMPEDANCE (Note 3)			MAXIMUM REVERSE CURRENT		MAXIMUM ZENER CURRENT @ 100°C	TYPICAL TEMP. COEFF. OF ZENER VOLTAGE	MAXIMUM SURGE CURRENT (Note 4)
	V_Z @	I_{ZT}	Z_{ZT} @ I_{ZT}	Z_{ZK} @	I_{ZK}	I_R @	V_R	I_{ZM}	$\alpha_{V(BR)}$	I_{ZSM}
	Volts	mA	Ohms	Ohms	mA	μA	Volts	mA	%/°C	Amps
1EZ110D5	110	2.3	570	5200	0.25	0.5	83.6	8.3	+0.095	0.15
1EZ120D5	120	2.0	710	5800	0.25	0.5	91.2	8.0	+0.095	0.14
1EZ130D5	130	1.9	910	6500	0.25	0.5	98.8	6.9	+0.095	0.13
1EZ140D5	140	1.8	1100	7000	0.25	0.5	106.4	6.5	+0.095	0.12
1EZ150D5	150	1.7	1300	7500	0.25	0.5	114	5.7	+0.095	0.12
1EZ160D5	160	1.6	1400	8000	0.25	0.5	121.6	5.4	+0.095	0.11
1EZ170D5	170	1.5	1450	8500	0.25	0.5	130.4	5.2	+0.095	0.10
1EZ180D5	180	1.4	1500	9000	0.25	0.5	136.8	4.9	+0.095	0.10
1EZ190D5	190	1.3	1700	9500	0.25	0.5	144.8	4.7	+0.095	0.10
1EZ200D5	200	1.2	1900	10000	0.25	0.5	152	4.6	+0.100	0.10

NOTES:

- Suffix 5 indicates +/-5% tolerance. Suffix 10 indicates +/-10%, no suffix indicates +/-20%. Also Suffix 1 indicates +/-1% and suffix 2 indicates +/-2% on V_Z tolerance.
- Voltage measurements to be performed 90 seconds after application of dc current at T_A 25°C (+8, -2°C). Test currents (I_{ZT}) have been selected so that power dissipation is 0.25 watts at nominal voltages. This results in a typical junction temperature rise of 10°C.
- The Zener impedance is derived from the 60 Hz ac voltage that results when an ac current having an rms value equal to 10% of the dc Zener current (I_{ZT} or I_{ZK}) is superimposed on I_{ZT} or I_{ZK} .
- Maximum Surge Current I_{ZSM} is a non recurrent maximum peak reverse surge with a pulse width of 8.3 ms.
- Glass devices may be ordered by replacing E in the series type number with G.
Example: 1GZ110D5

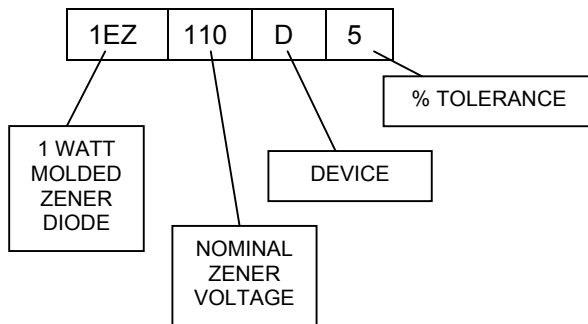

OUTLINE AND CIRCUIT

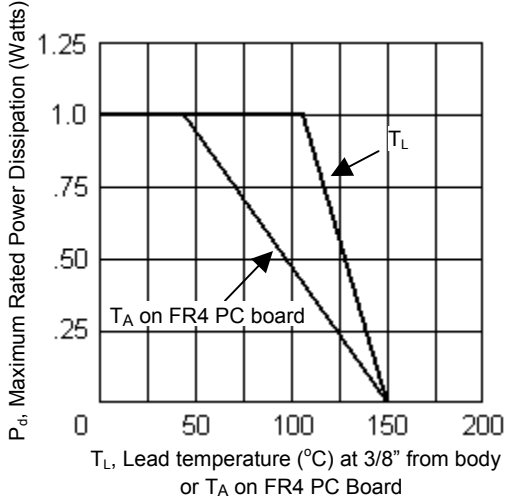
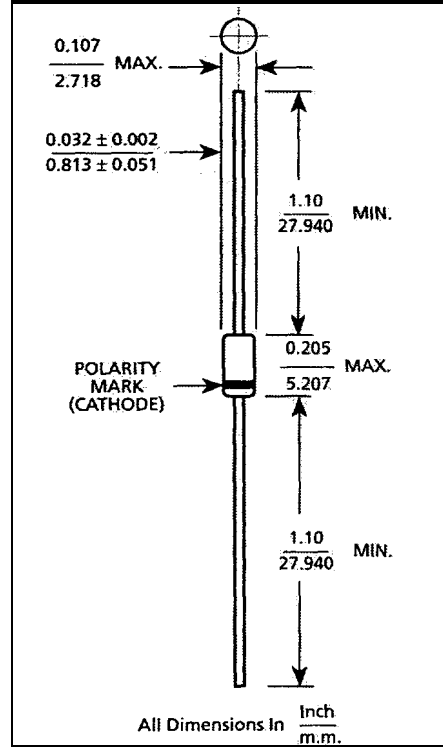

FIGURE 1
POWER DERATING CURVE

PACKAGE DIMENSIONS



This datasheet has been download from:

www.datasheetcatalog.com

Datasheets for electronics components.