

LOC	DIST	REVISIONS					
		P	LTR	DESCRIPTION	DATE	DWN	APVD
HJ	-		A6	Tolerance added	09SEP2009	UKo	HD
			B	Change marking	11SEP2009	UKo	HD
			C	Printing	10MAY2010	UKo	HD
			C1	Printing Date-Code	20AUG2010	UKo	HD

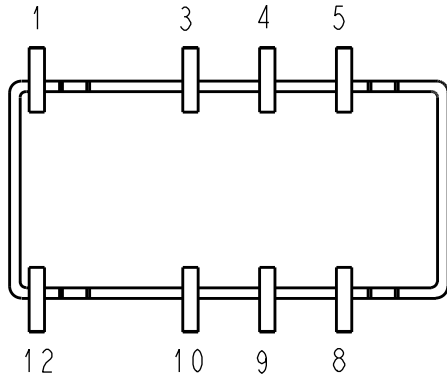

Relay - bottom view

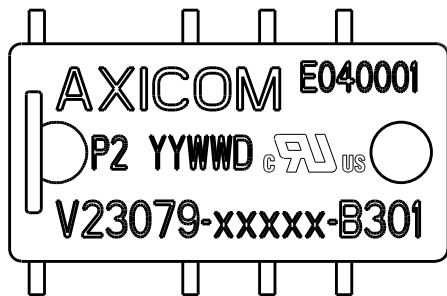
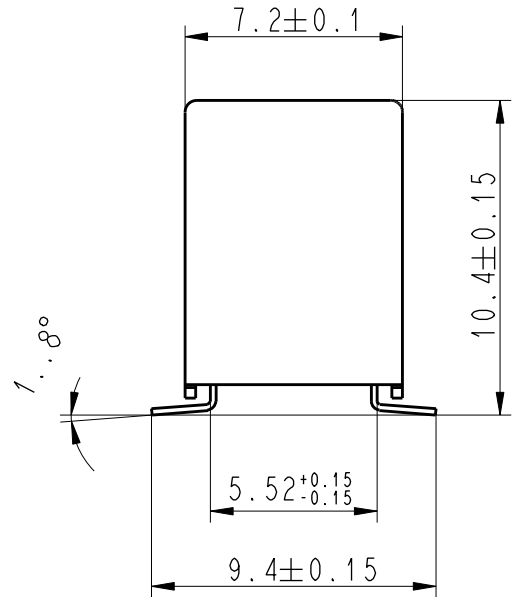
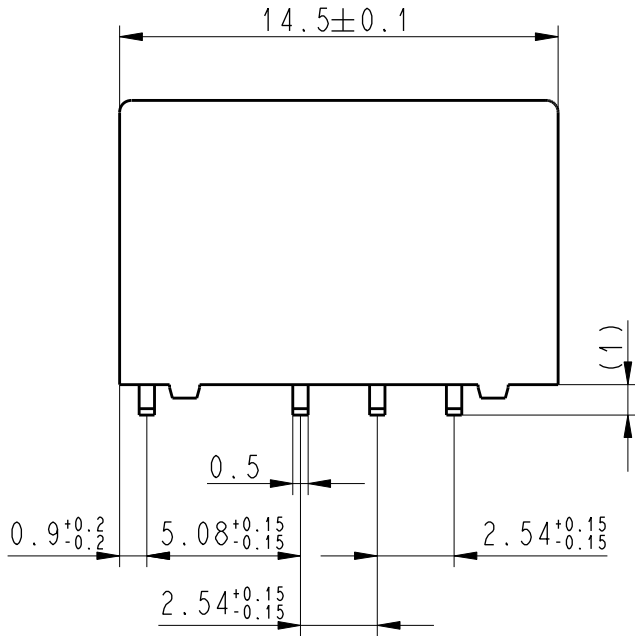

xxxxx = Relay type
YYWW = Date code

DRAWING ALIAS C23303-A079-A004

2006

RELEASED FOR PUBLICATION

THIS DRAWING IS UNPUBLISHED.

© COPYRIGHT 2006 BY TYCO ELECTRONICS CORPORATION. ALL RIGHTS RESERVED.

DIMENSIONS: mm	DWN	Korytak	02Jun2004	MATERIAL	-	FINISH	-
	CHK	Korytak	02Jun2004	Tyco Electronics AXICOM AG CZ-54101 Trutnov			
TOLERANCES UNLESS OTHERWISE SPECIFIED: DIN 7168-m	APVD	Korytak	02Jun2004				
0 PLC ±-	PRODUCT SPEC	NAME P2-Relay SMT W Dimensions					
1 PLC ±		SIZE A4 CAGE CODE 00779 DRAWING NO C-1393788-4 RESTRICTED TO -					
2 PLC ±	APPLICATION SPEC	CUSTOMER DRAWING SCALE 4:1 SHEET 1 OF 1 REV C1					
3 PLC ±							
4 PLC ±	WEIGHT						
ANGLES ±-							