

TOSHIBA BI-DIRECTIONAL TRIODE THYRISTOR SILICON PLANAR TYPE

SM6GZ47, SM6JZ47, SM6GZ47A, SM6JZ47A

AC POWER CONTROL APPLICATIONS

- Repetitive Peak Off-State Voltage: $V_{DRM} = 400V, 600V$
- R.M.S On-State Current: $I_T (RMS) = 6A$
- High Commutating (dv / dt)
- Isolation Voltage: $V_{ISOL} = 1500V AC$

MAXIMUM RATINGS

CHARACTERISTIC	SYMBOL	RATING	UNIT
Repetitive Peak Off-State Voltage and Repetitive Peak Reverse Voltage	SM6GZ47 SM6GZ47A	400	V
	SM6JZ47 SM6JZ47A	600	
R.M.S On-State Current (Full Sine Waveform $T_c = 90^\circ C$)	$I_T (RMS)$	6	A
Peak One Cycle Surge On-State Current (Non-Repetitive)	I_{TSM}	60 (50Hz)	A
		66 (60Hz)	
I^2t Limit Value	I^2t	18	A^2s
Critical Rate of Rise of On-State Current (Note 1)	di / dt	50	$A / \mu s$
Peak Gate Power Dissipation	P_{GM}	5	W
Average Gate Power Dissipation	$P_G (AV)$	0.5	W
Peak Gate Voltage	V_{FGM}	10	V
Peak Gate Current	I_{GM}	2	A
Junction Temperature	T_j	-40~125	$^\circ C$
Storage Temperature Range	T_{stg}	-40~125	$^\circ C$
Isolation Voltage (AC, $t = 1min.$)	V_{ISOL}	1500	V

Note 1: di / dt test condition

$$V_{DRM} = 0.5 \times \text{Rated}$$

$$I_{TM} \leq 9A$$

$$t_{gw} \geq 10\mu s$$

$$t_{gr} \leq 250ns$$

$$i_{gp} = I_{GT} \times 2.0$$

Unit: mm

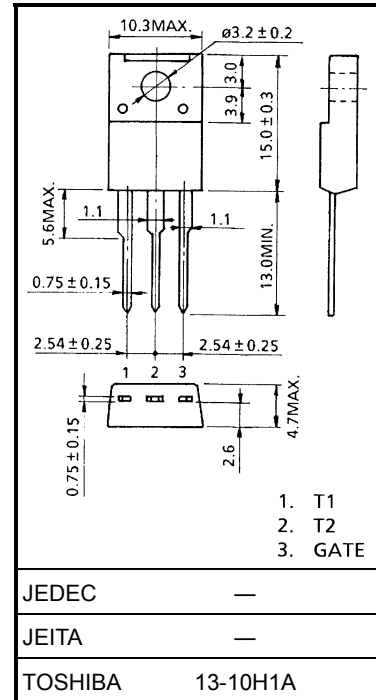

JEDEC	—
JEITA	—
TOSHIBA	13-10H1A

Weight: 1.7 g (typ.)

ELECTRICAL CHARACTERISTICS (Ta = 25°C)

CHARACTERISTIC		SYMBOL	TEST CONDITION		MIN	TYP.	MAX	UNIT
Repetitive Peak Off-State Current		I_{DRM}	$V_{DRM} = \text{Rated}$		—	—	20	μA
Gate Trigger Voltage	I	V_{GT}	$V_D = 12\text{V}$ $R_L = 20\Omega$	T2 (+), Gate (+)	—	—	1.5	V
	II			T2 (+), Gate (-)	—	—	1.5	
	III			T2 (-), Gate (-)	—	—	1.5	
	IV			T2 (-), Gate (+)	—	—	—	
Gate Trigger Current	SM6GZ47 SM6JZ47	I_{GT}	$V_D = 12\text{V}$ $R_L = 20\Omega$	T2 (+), Gate (+)	—	—	30	mA
				T2 (+), Gate (-)	—	—	30	
				T2 (-), Gate (-)	—	—	30	
				T2 (-), Gate (+)	—	—	—	
	SM6GZ47A SM6JZ47A			T2 (+), Gate (+)	—	—	20	
				T2 (+), Gate (-)	—	—	20	
				T2 (-), Gate (-)	—	—	20	
				T2 (-), Gate (+)	—	—	—	
Peak On-State Voltage		V_{TM}	$I_{TM} = 9\text{A}$		—	—	1.5	V
Gate Non-Trigger Voltage		V_{GD}	$V_D = \text{Rated}, T_c = 125^\circ\text{C}$		0.2	—	—	V
Holding Current		I_H	$V_D = 12\text{V}, I_{TM} = 1\text{A}$		—	—	50	mA
Thermal Resistance		$R_{th(j-c)}$	Junction to Case		—	—	3.8	$^\circ\text{C} / \text{W}$
Critical Rate of Rise of Off-State Voltage	SM6GZ47 SM6JZ47	dv / dt	$V_{DRM} = \text{Rated}, T_j = 125^\circ\text{C}$ Exponential Rise	—	300	—	V / μs	
	SM6GZ47A SM6JZ47A			—	200	—		
Critical Rate of Rise of Off-State Voltage at Commutation	SM6GZ47 SM6JZ47	$(dv / dt)_c$	$V_{DRM} = 400\text{V}, T_j = 125^\circ\text{C}$ $(di / dt)_c = -3.3\text{A} / \text{ms}$	10	—	—	V / μs	
	SM6GZ47A SM6JZ47A			4	—	—		

MARKING

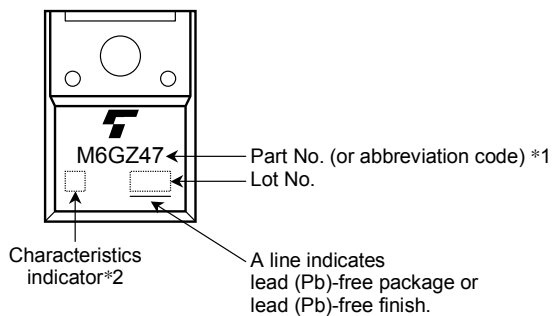

	Part No. (or abbreviation code)	Part No.
*1	M6GZ47	SM6GZ47, SM6GZ47A
	M6JZ47	SM6JZ47, SM6JZ47A
*2	Nothing	SM6GZ47, SM6JZ47
	A	SM6GZ48A, SM6JZ47A

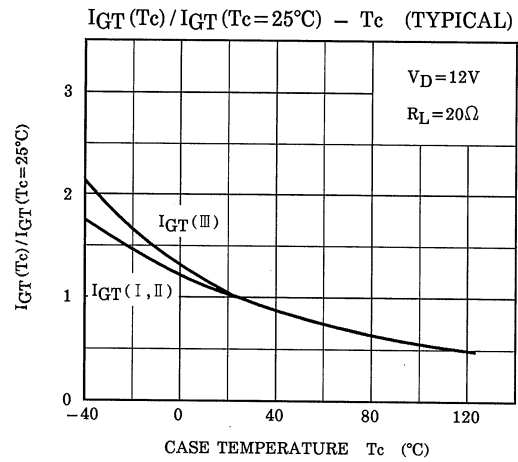
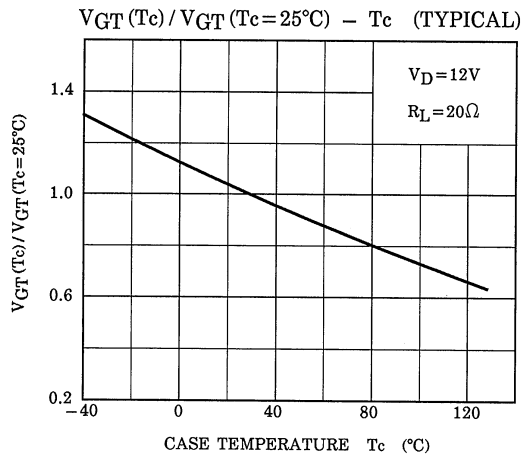
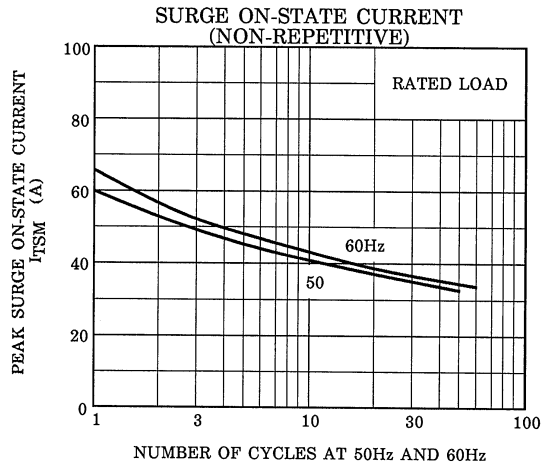
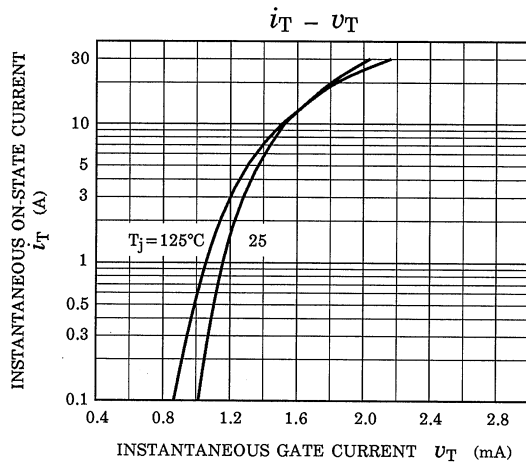
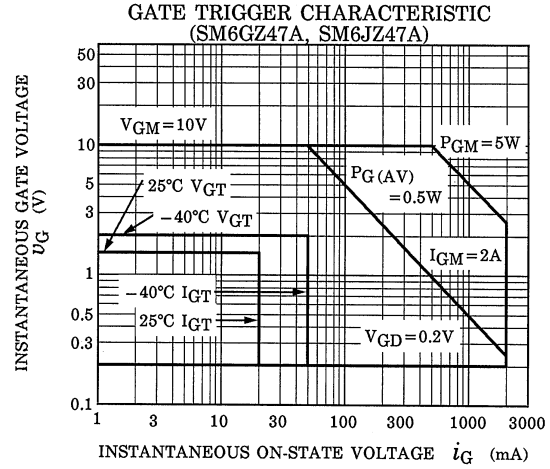
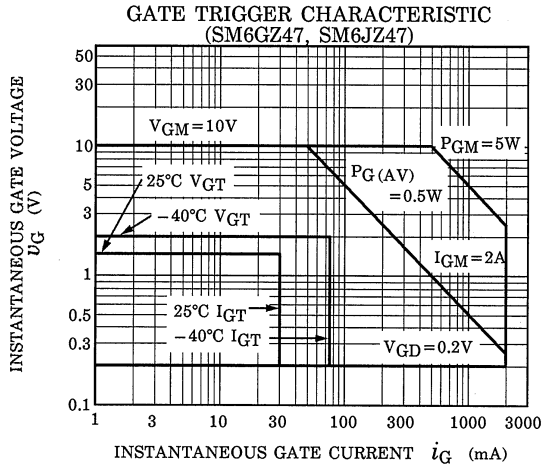

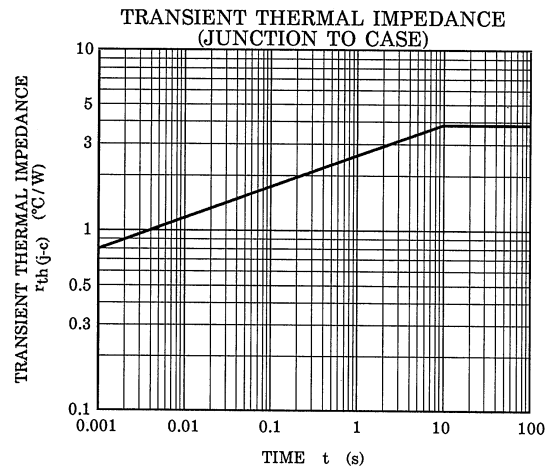
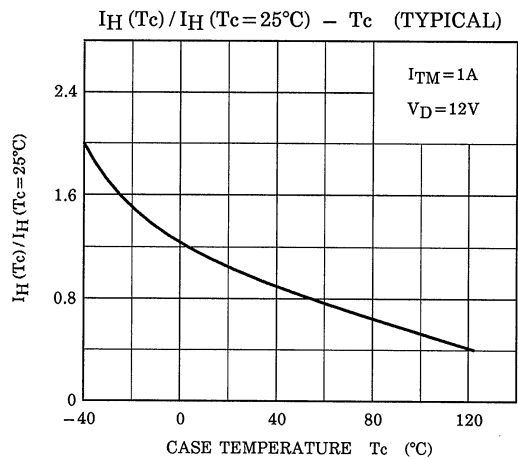
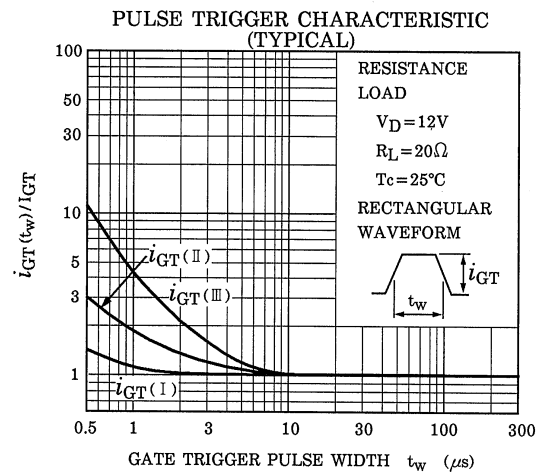
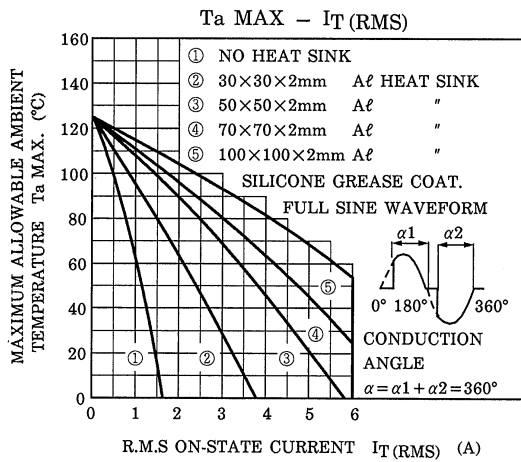
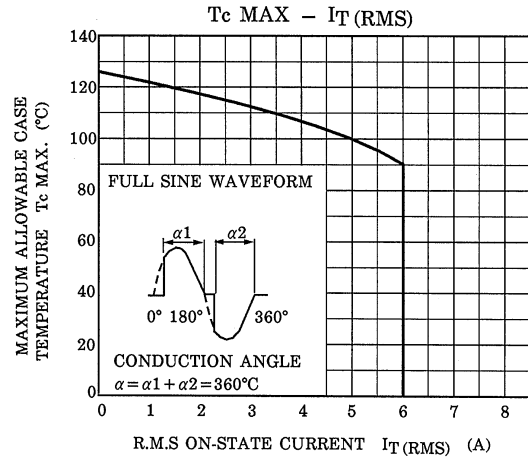
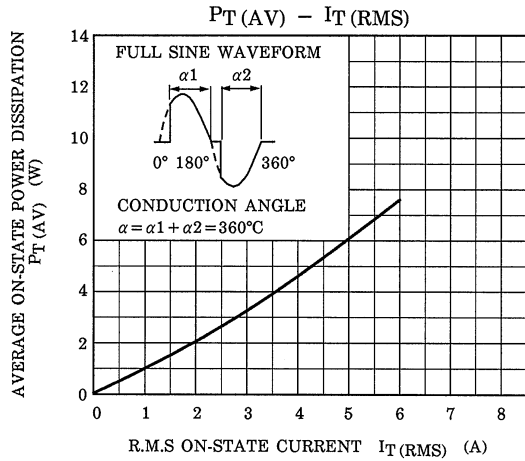

RESTRICTIONS ON PRODUCT USE

030619EAA

- The information contained herein is subject to change without notice.
- The information contained herein is presented only as a guide for the applications of our products. No responsibility is assumed by TOSHIBA for any infringements of patents or other rights of the third parties which may result from its use. No license is granted by implication or otherwise under any patent or patent rights of TOSHIBA or others.
- TOSHIBA is continually working to improve the quality and reliability of its products. Nevertheless, semiconductor devices in general can malfunction or fail due to their inherent electrical sensitivity and vulnerability to physical stress. It is the responsibility of the buyer, when utilizing TOSHIBA products, to comply with the standards of safety in making a safe design for the entire system, and to avoid situations in which a malfunction or failure of such TOSHIBA products could cause loss of human life, bodily injury or damage to property.
In developing your designs, please ensure that TOSHIBA products are used within specified operating ranges as set forth in the most recent TOSHIBA products specifications. Also, please keep in mind the precautions and conditions set forth in the "Handling Guide for Semiconductor Devices," or "TOSHIBA Semiconductor Reliability Handbook" etc..
- The TOSHIBA products listed in this document are intended for usage in general electronics applications (computer, personal equipment, office equipment, measuring equipment, industrial robotics, domestic appliances, etc.). These TOSHIBA products are neither intended nor warranted for usage in equipment that requires extraordinarily high quality and/or reliability or a malfunction or failure of which may cause loss of human life or bodily injury ("Unintended Usage"). Unintended Usage include atomic energy control instruments, airplane or spaceship instruments, transportation instruments, traffic signal instruments, combustion control instruments, medical instruments, all types of safety devices, etc.. Unintended Usage of TOSHIBA products listed in this document shall be made at the customer's own risk.
- TOSHIBA products should not be embedded to the downstream products which are prohibited to be produced and sold, under any law and regulations.