

PANEL THICKNESS	X dimension
0.75~1.25 [0.030~0.049]	30.0 +0.2 [1.181]
1.25~2.0 [0.049~0.079]	30.2 +0.2 [1.189]
2.0~3.0 [0.079~0.118]	30.6 +0.2 [1.205]

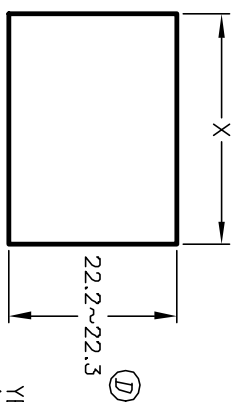

RECOMMENDED PANEL MOUNTING

NOT TO SCALE  
(ILLUMINATED)

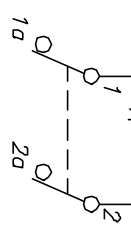

CIRCUIT: DPST  
ON-OFF

- NOTES:
1. ALL DIMENSIONS IN MM [INCH]
  2. GENERAL TOLERANCE: X.XX=±0.4  
X.XX=±0.25
  3. TERM. NOS. FOR REF. ONLY
  4. RATING: 20A @125VAC;  
15A @250VAC. (Normal Conditions)
  5. LAMP VOLTAGE: 250V (NEON BULB)
  6. MATERIAL:  
CONTACT SURFACE: Coin Silver, Silver Plated.  
TERMINAL: Copper ALLOY w/Silver plate
  7. ELECTRICAL LIFE: ≥10,000 cycles
  8. MECHANICAL LIFE: 30,000 cycles
  9. CONTACT RESISTANCE: <20 mΩ-Ohms initial
  10. DIELECTRIC STRENGTH: >1,500V AC 1min  
>3,000V between poles.

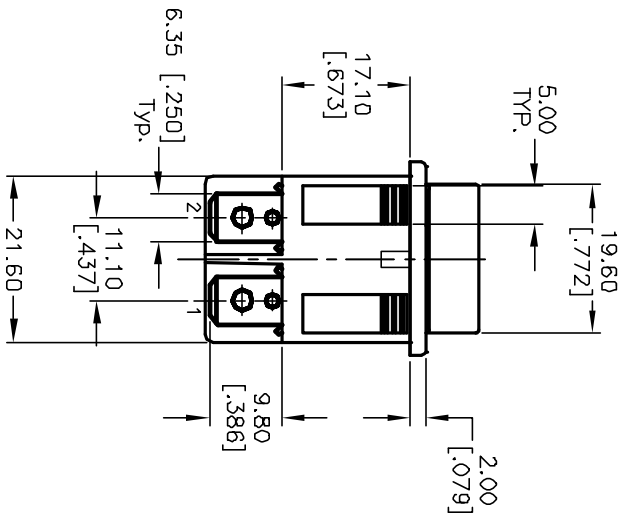
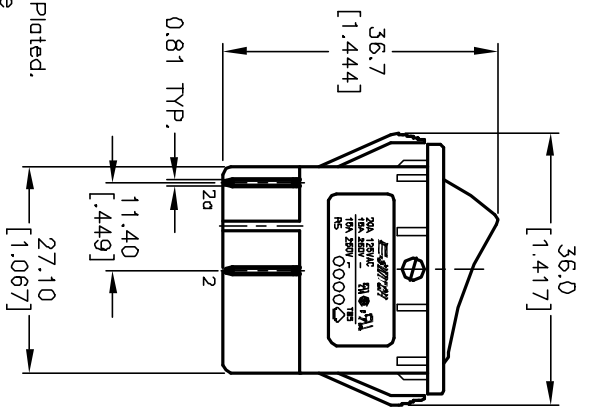
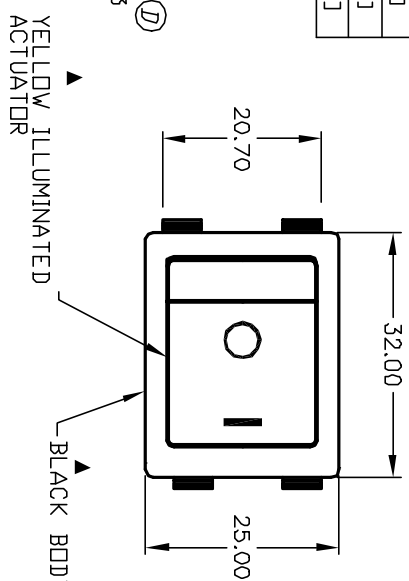

NEON BULB

PARAMETERS	SYMBOL	MAX.	UNITS
LAMP VOL TAGE (AC)	V	250	V
STARTUP VOL TAGE	Vs	95	V
CURRENT	I	0.9	mA
SERIES RESISTANCE	R	270	OHMS

REV.	ECN No.	DESCRIPTION	DATE	CHKD
D	12776	REVISED PANEL CUTOUT	1/29/03	CJB
C	12296	REVISED	10/4/02	CJB
B	12172	REDUCED TABS FROM 4 TO 2	5/13/02	CJB

**E-SWITCH®**

TITLE: RSB BLK YEL GF2

SCALE: 1:1      DATE: 9/28/01      DR: CJB      DWG: M050221      REV: D

THE INFORMATION CONTAINED IN THIS DOCUMENT IS PROPRIETARY TO E-SWITCH AND IS NOT TO BE COPIED OR TRANSFERRED