

Features

- 48vin, Isolated, 4:1 Fixed Conversion Ratio (12v Nominal Out)
- 240watt Max Output
- Parallel For Higher Output Power
- ±10% Current Share Accuracy
- Over-temperature Protection
- 96% Efficiency
- Remote Enable (Primary Side)
- Positive or Negative Enable Logic
- Current Limit
- Vertical Mount



This product is not fuse protected. User is responsible for providing system protection. Consult factory for application information.

Table 1:

Input Characteristics	Notes and Conditions (1)	Min	Typ	Max	Units
Input Voltage Operating Range		36	48	55	Vdc
Input Voltage Absolute Maximum				60	Vdc
Input Undervoltage Lockout	Turn-on Threshold	36.5		37.6	Vdc
	Turn-off Threshold	34.5		35.5	Vdc
Maximum Input Current	Steady-State (20Amp output)		5.1		Adc
No-Load Input Current	Enable state, on Load (48Vin)		72		mA
Disabled Input Current	Disabled State (48V input)		21		mA
Input Reflected Ripple Current (2)				50	mArms
Inrush Current Transient			0.20		A ² s
Enable - Negative Logic Version Internal 10K pull-up to 6.2V	On State Range	-0.6		0.7	Vdc
	Off State Range	0.8		6.2	Vdc
Enable - Positive Logic Version Internal 100K pull-down to gnd	On State Range	0.8		6.2	Vdc
	Off State Range	-0.6		0.7	Vdc

Table 2:

Output Characteristics	Notes and Conditions (1)	Min	Typ	Max	Units
Output Voltage Set Point	(Vin/4) +1% / -1%		12		Vdc
Output Load Regulation	(Vin/4) + 1% / -5%	-5	-3	1	%
Output Voltage Total Regulation		8.5		13.9	Vdc
Output Ripple Voltage & Noise (3)	20 MHz Bandwidth		90	150	mVp-p
Output Current Operating Range (4)		0		20	A
Efficiency	Io=20A, Vin=48V (See curves)		95.6		%
Turn-on Time	Vin present: Enable to 90% Vout			10	mS

Table 2:

Output Characteristics	Notes and Conditions (1)	Min	Typ	Max	Units
Transient Response (5)	5A Step 0.1A/μS, ΔVo			150	mV
	Recovery Time			100	μS
Maximum Output Capacitance	Max			3000	μF

Table 3:

Protection Characteristics	Notes and Conditions (1)	Min	Typ	Max	Units
Output Overcurrent Inception Limit		20	27	30	A _{dc}
Output Overcurrent Shutdown (Latching after second re-try)	Restart Rate		1700		mS
Short Circuit Current	Peak			30	A _{pk}
Overtemperature Shutdown	Non-Latching			125	°C
Overtemperature Restart Hysteresis			10		°C

Table 4:

General Characteristics	Notes and Conditions (1)	Min	Typ	Max	Units
Isolation Voltage	Input to Output			2000	V _{dc}
Isolation Resistance	Input to Output	10			Mohm
Storage Temperature Range	Non-condensing	-40		125	°C
Operating Temperature Range		-40		85	°C
Agency Approvals	UL 60950-1, IEC 60950-1, TUV 60950-1				
Material Flammability	UL 94V-0				
MTBF	Calculated (RAC PRISM) 50°C		1.52		x10 ⁶ Hrs
Dimensions	Vertical	2.50"L x 1.25"H x 0.380"W			
Weight			35		g

Notes:

1. Vin = 48Vdc, Ta = 20°C, Airflow = 200LFM unless otherwise noted.
2. Input Reflected Ripple Current is specified when measured with a 120μF 63V electrolytic capacitor across the input pins.
3. Output Ripple Voltage is specified when measured with a 270μF electrolytic and a 10μF ceramic capacitor at the converter output pins.
4. De-rating curves are conducted in a controlled environment. End application testing is required to ensure the hot spot temperature is below the maximum specified.
5. Transient response is specified with 270μF electrolytic and 10μF ceramic at the converter output pins.

Mechanical Information - Vertical

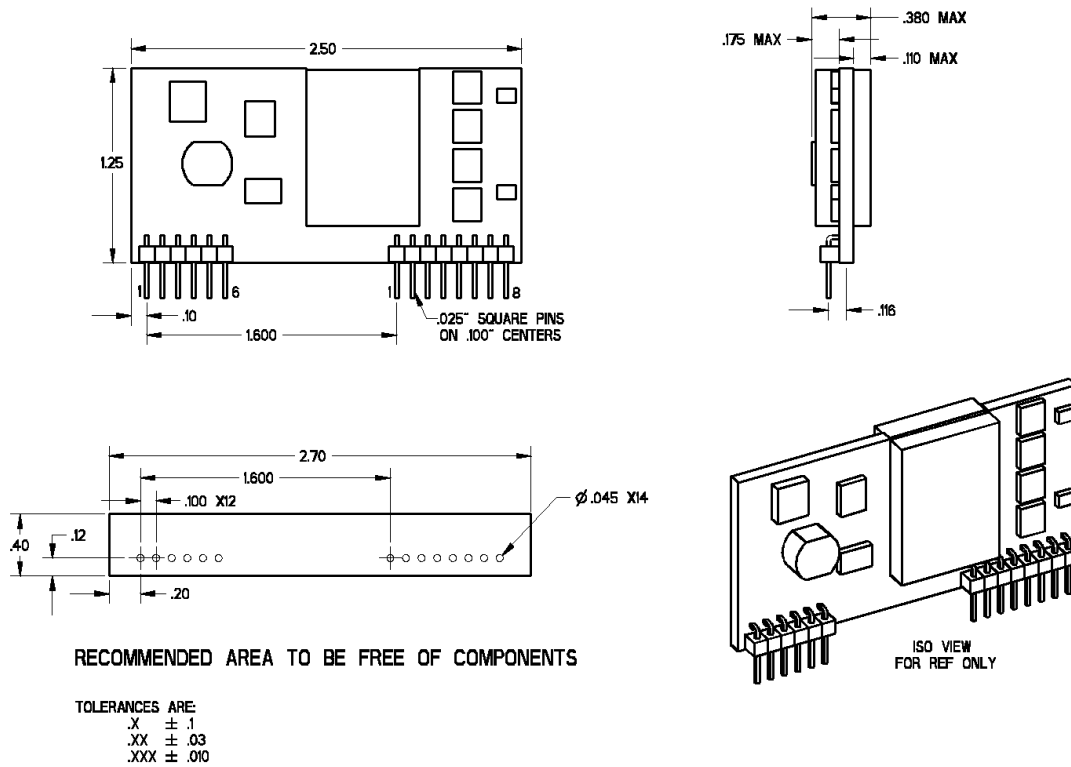

Figure 1

Pin Assignment - Vertical

Table 5:

Connector	Pin #	Pin Name	Function	Connector	Pin #	Pin Name	Function
J1	1	ON/OFF	Referenced to Vin-	J2	1	VOUT-	Secondary return
	2	NC			2	VOUT+	Output, 12V nominal, 20A max
	3	VIN+	Vin 36 to 55Vdc		3	VOUT-	Secondary return
	4	VIN-	Primary return		4	VOUT+	OUT
	5	VIN+	Vin 36 to 55Vdc		5	VOUT-	Secondary return
	6	VIN-	Primary return		6	VOUT+	OUT
					7	VOUT-	Secondary return
					8	VOUT+	OUT

Efficiency Curves

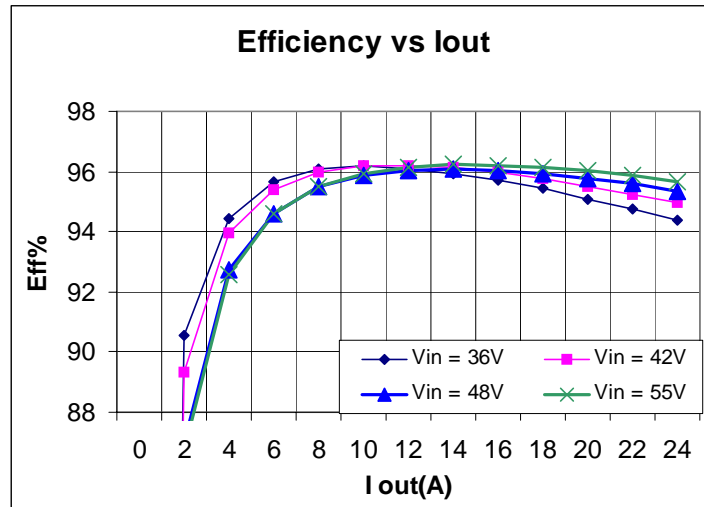

Figure 2

Vout vs. Load

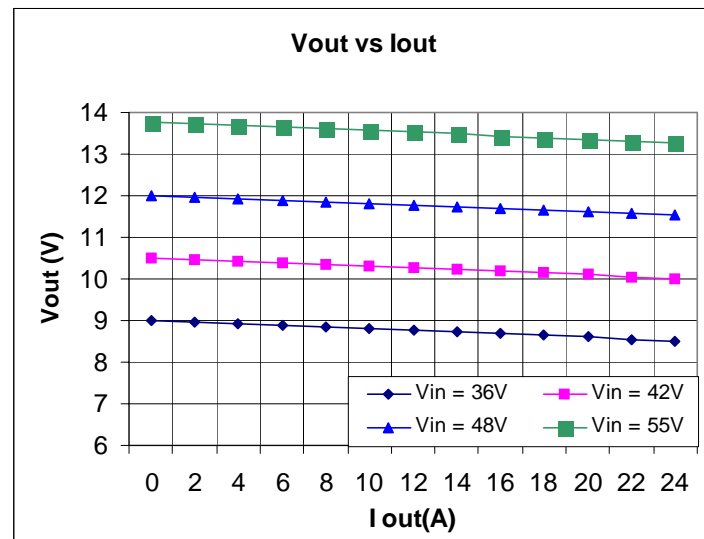

Figure 3

Derating - Vertical Mount

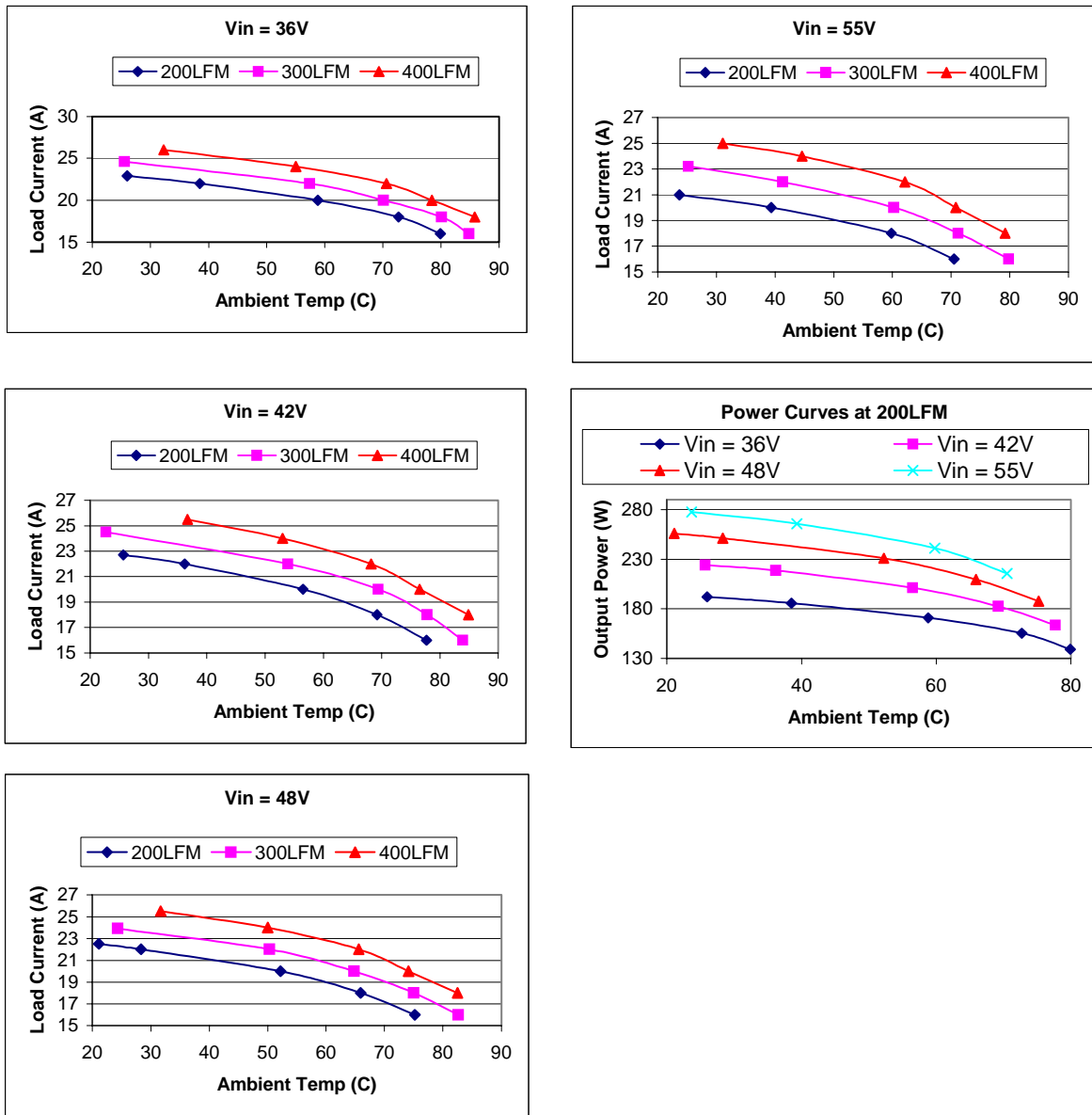
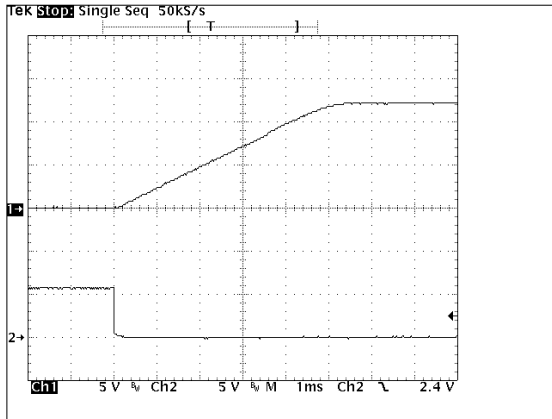
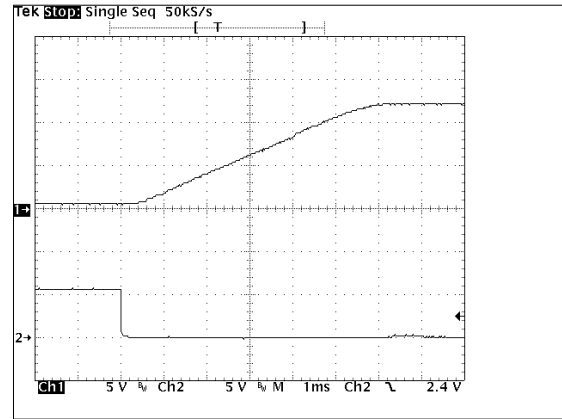

Figure 4

Start up from Enable



Vin = 48V, Iout = 20A



Vin = 48V, Iout = 0A

Figure 5

Transient Response

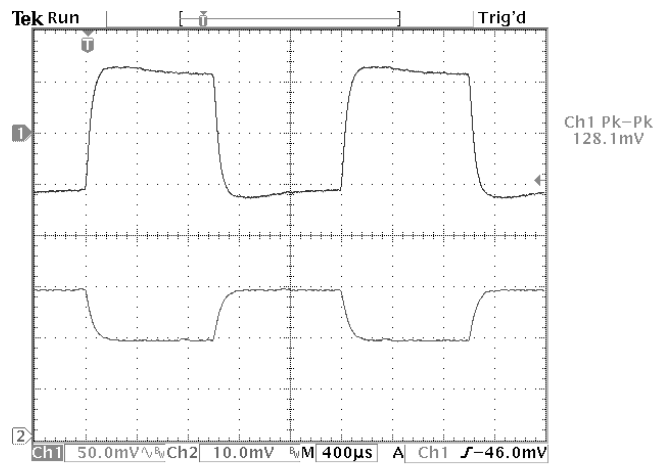

Iout 10A to 15A at 0.1A/µS
CH1 Vout 50mV/div, CH2 Iout 5A/div

Figure 6

Output Voltage Ripple

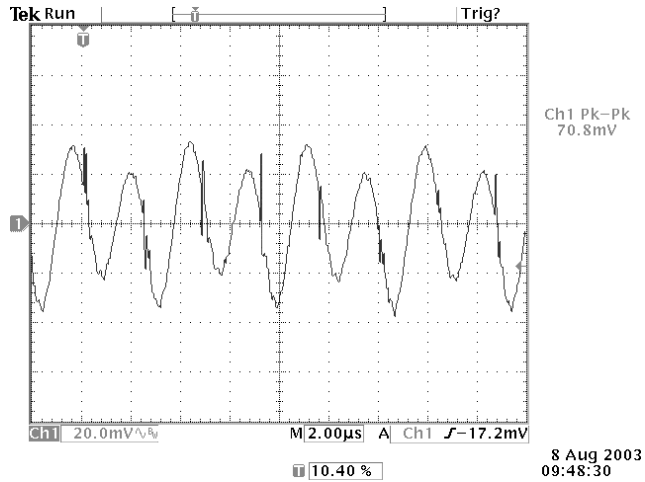

Vin = 48V, Iout = 20A; BW = 20MHz

Figure 7

Input Ripple

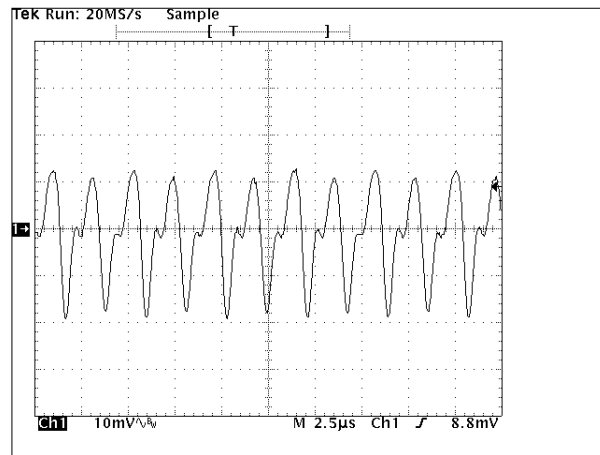

Vin = 48V, Iout = 20A; BW = 20MHz 5mA/div

Figure 8

Ordering Information

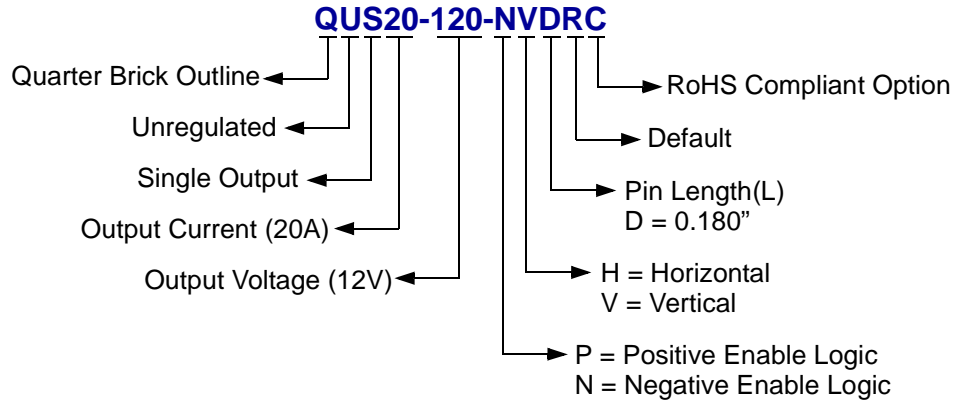

RoHS Compliancy

The QUS20-120-NVRDC is in compliance with the European Union Directive 2002/95/EC (RoHS) with respect to the following substances: lead (Pb), cadmium (Cd), mercury (Hg), hexavalent chromium (Cr6), polybrominated biphenyls (PBB) or polybrominated diphenyl ethers (PBDE).

RoHS Process Note

This product is not intended to go through a reflow solder process. Use wave solder, selective solder or hand solder process with a peak temperature of 260°C for 10 seconds.

C&D Technologies, Inc. reserves the right to alter or improve the specification, internal design or manufacturing process at any time, without notice. Please check with your supplier or visit our website to ensure that you have the current and complete specification for your product before use.

© C&D Technologies, Inc. 2004

No part of this publication may be copied, transmitted, or stored in a retrieval system or reproduced in any way including, but not limited to, photography, photocopy, magnetic or other recording means, without prior written permission from C&D Technologies, Inc.

Instructions for use are available from: www.cd4power.com

4118 14th Avenue, Suite 4
Markham, Ontario L3R 0J3
1-905-944-2850

www.cd4power.com

4607 S.E. International Way
Milwaukie, Oregon 97222
1-971-206-2800