

1 2 3 4 5 6 7 8

REVISIONS		
ISS	ZONE	DESCRIPTION\PER REQUEST\DATE

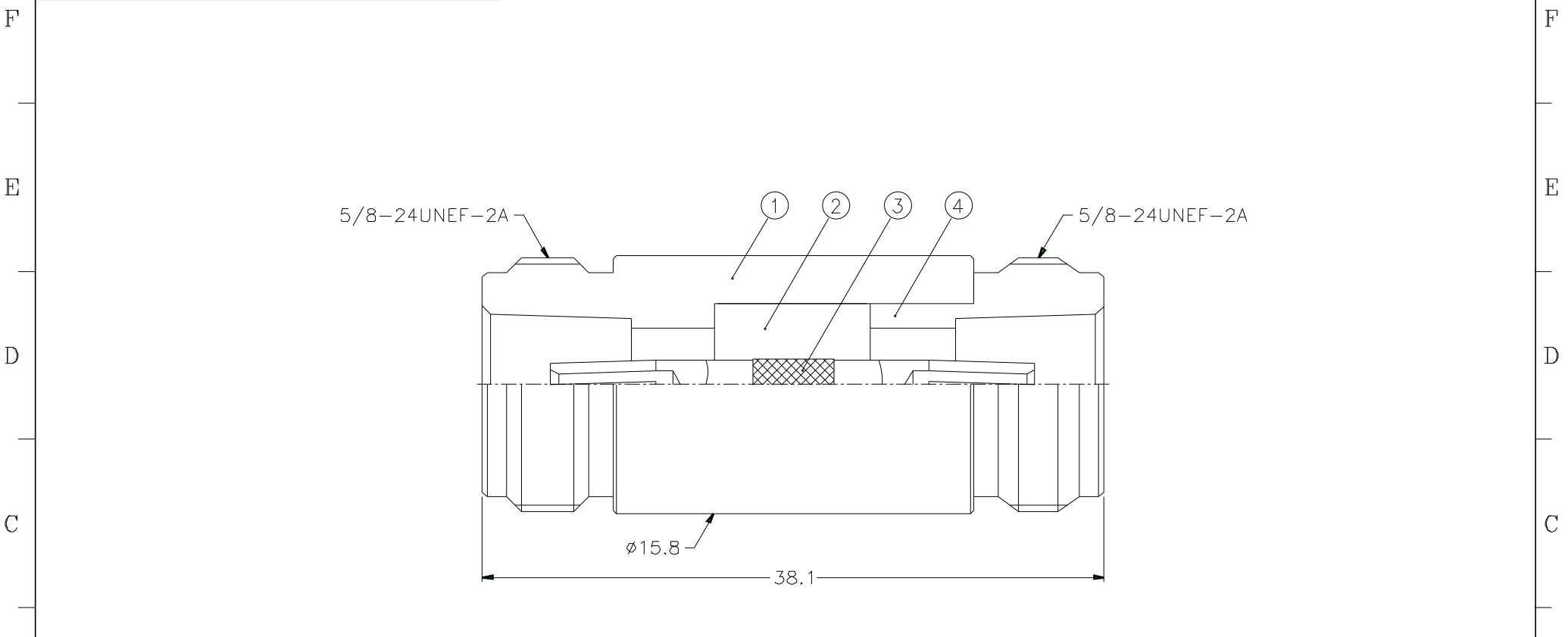

NOTES: FINISH (PLATING THICKNESS IN MICRO-INCHES)  
 1. BRASS PER QQ-B-626  
 2. NICKEL PL. 100 MIN. THICK OVER COPPER STRIKE  
 3. PHOSPHOR BRONZE PER QQ-B-750  
 4. GOLD PL. 3 MIN. THICK OVER NICKEL PL. 100 MIN. THICK OVER COPPER STRIKE  
 5. TEFLON MIL-P-19468

4	BODY	NOTE 1	NOTE 2	1	N7900-4
3	CONTACT PIN	NOTE 3	NOTE 4	1	N7900-3
2	INSULATOR	NOTE 5	NATURAL	1	N7900-2T-50-B
1	HOUSING	NOTE 1	NOTE 2	1	N7900-1
NO.	DESCRIPTION	MATERIAL	FINISH	Q'TY	DRAWING NO.

DIMENSIONS ARE IN MILLIMETERS			
UNLESS OTHERWISE SPECIFIED TOLERANCES			
0-5	-6	=	$\pm 0.2$
6-30	=	$\pm 0.4$	
30-120	=	$\pm 0.6$	
120-315	=	$\pm 1$	
315-1000	=	$\pm 1.6$	
1000-2000	=	$\pm 2.4$	
SCALE	3/1	ISSUE	A
PART NO.	N7071A1-NT3G-50		
APPROVED		DATE	10-11-01'
CHECKED		DATE	10-11-01'
DRAWN		DATE	10-11-01'
FILE NO.	DRAWING NO.		

**Amphenol**

TITLE  
N FEMALE TO FEMALE ADAPTOR

DRAWING NO.  
KJ-N7071A1-NT3G-50

ITEM NO.

1 2 3 4 5 6 7 8