

TOSHIBA INTELLIGENT POWER MODULE SILICON N CHANNEL IGBT

# MIG150Q6CMA0X (1200V / 150A 6in1)

HIGH POWER SWITCHING APPLICATION

MOTOR CONTROL APPLICATION

- Integrates Inverter Power Circuits & Control Circuits (IGBT drive units, Protection units for Short-Current, Over-Current, Under-Voltage & Over Temperature) in One Package.
- The Electrode are Isolated from Case.
- $V_{CE(sat)} = 2.4\text{ V (Typ.)}$

## EQUIVALENT CIRCUIT

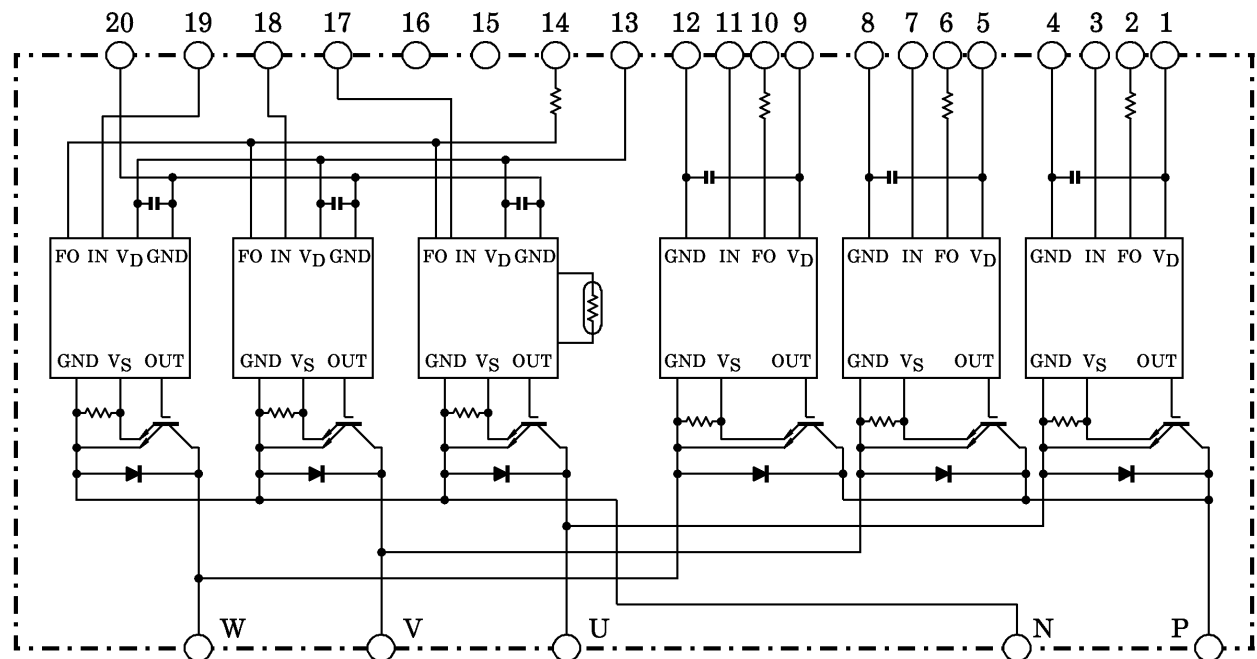

- |             |             |           |           |             |              |           |
|-------------|-------------|-----------|-----------|-------------|--------------|-----------|
| 1. $V_D(U)$ | 2. FO(U)    | 3. IN(U)  | 4. GND(U) | 5. $V_D(V)$ | 6. FO(V)     | 7. IN(V)  |
| 8. GND(V)   | 9. $V_D(W)$ | 10. FO(W) | 11. IN(W) | 12. GND(W)  | 13. $V_D(L)$ | 14. FO(L) |
| 15. Open    | 16. Open    | 17. IN(X) | 18. IN(Y) | 19. IN(Z)   | 20. GND(L)   |           |

961001EAA1

- TOSHIBA is continually working to improve the quality and the reliability of its products. Nevertheless, semiconductor devices in general can malfunction or fail due to their inherent electrical sensitivity and vulnerability to physical stress. It is the responsibility of the buyer, when utilizing TOSHIBA products, to observe standards of safety, and to avoid situations in which a malfunction or failure of a TOSHIBA product could cause loss of human life, bodily injury or damage to property. In developing your designs, please ensure that TOSHIBA products are used within specified operating ranges as set forth in the most recent products specifications. Also, please keep in mind the precautions and conditions set forth in the TOSHIBA Semiconductor Reliability Handbook.
- The information contained herein is presented only as a guide for the applications of our products. No responsibility is assumed by TOSHIBA CORPORATION for any infringements of intellectual property or other rights of the third parties which may result from its use. No license is granted by implication or otherwise under any intellectual property or other rights of TOSHIBA CORPORATION or others.
- The information contained herein is subject to change without notice.

OUTLINE : TOSHIBA 2-123A1A

Unit : mm

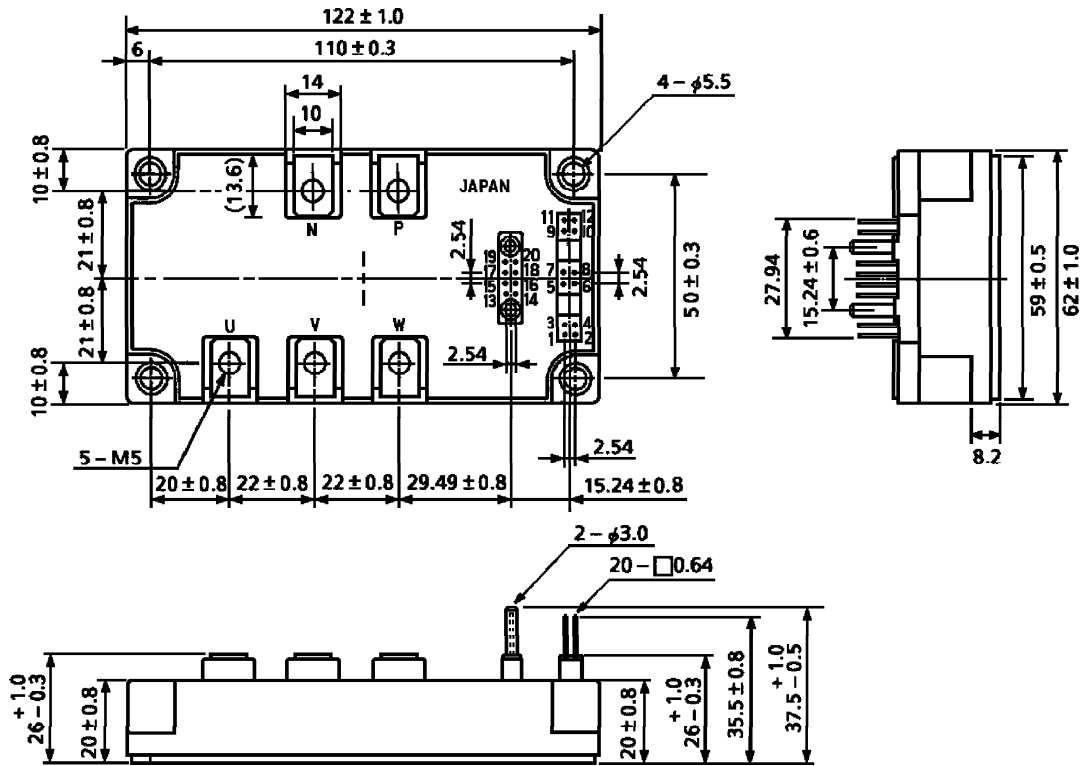

- |               |             |              |            |              |             |
|---------------|-------------|--------------|------------|--------------|-------------|
| 1. $V_D$ (U)  | 2. FO (U)   | 3. IN (U)    | 4. GND (U) | 5. $V_D$ (V) | 6. FO (V)   |
| 7. IN (V)     | 8. GND (V)  | 9. $V_D$ (W) | 10. FO (W) | 11. IN (W)   | 12. GND (W) |
| 13. $V_D$ (L) | 14. FO (L)  | 15. Open     | 16. Open   | 17. IN (X)   | 18. IN (Y)  |
| 19. IN (Z)    | 20. GND (L) |              |            |              |             |

Weight : 375 g (Typ.)

SIGNAL TERMINAL LAYOUT

Unit : mm

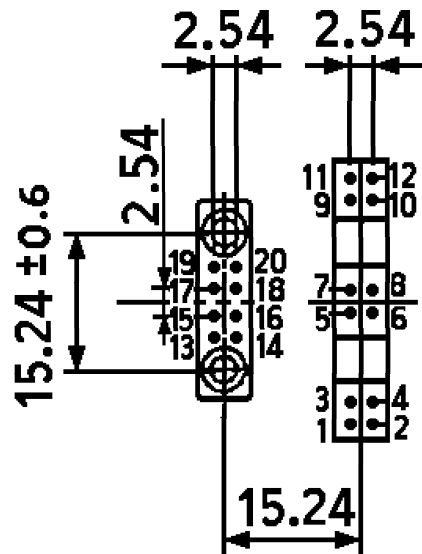

- |                        |            |                       |           |                       |            |
|------------------------|------------|-----------------------|-----------|-----------------------|------------|
| 1. V <sub>D</sub> (U)  | 2. FO(U)   | 3. IN(U)              | 4. GND(U) | 5. V <sub>D</sub> (V) | 6. FO(V)   |
| 7. IN(V)               | 8. GND(V)  | 9. V <sub>D</sub> (W) | 10. FO(W) | 11. IN(W)             | 12. GND(W) |
| 13. V <sub>D</sub> (L) | 14. FO(L)  | 15. Open              | 16. Open  | 17. IN(X)             | 18. IN(Y)  |
| 19. IN(Z)              | 20. GND(L) |                       |           |                       |            |

MAXIMUM RATINGS

STAGE	CHARACTERISTIC	CONDITION	SYMBOL	RATING	UNIT
Inverter	Supply Voltage	P-N Power Terminal	$V_{CC}$	900	V
	Collector-Emitter Voltage	—	$V_{CES}$	1200	V
	Collector Current	$T_c = 25^\circ\text{C}$ , DC	$I_C$	150	A
	Forward Current	$T_c = 25^\circ\text{C}$ , DC	$I_F$	150	A
	Collector Power Dissipation	$T_c = 25^\circ\text{C}$	$P_C$	1000	W
	Junction Temperature	—	$T_j$	150	$^\circ\text{C}$
Control	Control Supply Voltage	$V_D$ -GND Terminal	$V_D$	20	V
	Input Voltage	IN-GND Terminal	$V_{IN}$	20	V
	Fault Output Voltage	FO-GND Terminal	$V_{FO}$	20	V
	Fault Output Current	FO Sink Current	$I_{FO}$	14	mA
Module	Operating Temperature	—	$T_c$	-20~+100	$^\circ\text{C}$
	Storage Temperature Range	—	$T_{stg}$	-40~+125	$^\circ\text{C}$
	Isolation Voltage	AC 1 minute	$V_{ISO}$	2500	V
	Screw Torque	M5	—	3	Nm

ELECTRICAL CHARACTERISTICS

a. Inverter Stage ( $T_j = 25^\circ\text{C}$ )

CHARACTERISTIC	SYMBOL	TEST CONDITION	MIN.	TYP.	MAX.	UNIT	
Collector Cut-Off Current	$I_{CEX}$	$V_{CE} = 1200\text{ V}$	$T_j = 25^\circ\text{C}$	—	—	1	mA
			$T_j = 125^\circ\text{C}$	—	—	10	
Collector-Emitter Saturation Voltage	$V_{CE}(\text{sat})$	$V_D = 15\text{ V}$ , $I_C = 150\text{ A}$ , $V_{IN} = 15\text{ V} \rightarrow 0\text{ V}$	$T_j = 25^\circ\text{C}$	—	2.4	2.8	V
			$T_j = 125^\circ\text{C}$	—	—	3.2	
Forward Voltage	$V_F$	$I_F = 150\text{ A}$	—	2.5	3.1	V	
Switching Time	$t_{on}$	$V_{CC} = 600\text{ V}$ , $I_C = 150\text{ A}$ $V_D = 15\text{ V}$ , $V_{IN} = 15\text{ V} \leftrightarrow 0\text{ V}$ Inductive Load (Note 1)	—	1.0	2.0	$\mu\text{s}$	
	$t_c(\text{on})$		—	0.6	1.2		
	$t_{rr}$		—	0.3	0.6		
	$t_{off}$		—	2.0	3.0		
	$t_c(\text{off})$		—	0.3	0.7		

b. Control Stage ( $T_j = 25^\circ\text{C}$ )

CHARACTERISTIC		SYMBOL	TEST CONDITION	MIN.	TYP.	MAX.	UNIT
Control Circuit Current	High Side	$I_D(H)$	$V_D = 15\text{ V}$	—	8	12	mA
	Low Side	$I_D(L)$		—	34	50	
Input On Signal Voltage		$V_{IN(on)}$	$V_D = 15\text{ V}$	1.4	1.6	1.8	V
Input Off Signal Voltage		$V_{IN(off)}$		2.2	2.5	2.8	
Fault Output Current	Protection	$I_{FO(on)}$	$V_D = 15\text{ V}$	—	10	12	mA
	Normal	$I_{FO(off)}$		—	—	0.1	
Over Current Protection Trip Level	Inverter	OC	$V_D = 15\text{ V}, T_j \leq 125^\circ\text{C}$	240	—	—	A
Short Circuit Protection Trip Level	Inverter	SC	$V_D = 15\text{ V}, T_j \leq 125^\circ\text{C}$	300	—	—	A
Over Current Cut-Off Time		$t_{off(OC)}$	$V_D = 15\text{ V}$	—	5	—	$\mu\text{s}$
Over Temperature Protection	Trip Level	OT	Case Temperature	110	118	125	$^\circ\text{C}$
	Reset Level	OTr		—	98	—	
Control Supply Under Voltage Protection	Trip Level	UV	—	11.0	12.0	12.5	V
	Reset Level	UVr		12.0	12.5	13.0	
Fault Output Pulse Width		$t_{FO}$	$V_D = 15\text{ V}$	1	2	3	ms

c. Thermal Resistance ( $T_c = 25^\circ\text{C}$ )

CHARACTERISTIC	SYMBOL	TEST CONDITION	MIN.	TYP.	MAX.	UNIT
Junction to Case Thermal Resistance	$R_{th(j-c)}$	IGBT	—	—	0.125	$^\circ\text{C} / \text{W}$
		FRD	—	—	0.357	

(Note 1) : Switching time test circuit & timing chart

