

DIFFERENTIAL CONNECTOR

FCN-260(D) Series microGiGaCN™

RoHS Compliant



■ FEATURES

- I/O Connector designed for high speed differential signal applications.
- Matched Impedance (100 ohms \pm 10%)
- Low insertion loss
- Low cross talk
- Adopted by InfiniBand as 10G Ethernet, SAS, & SATA for 4x/12x Interface



■ SPECIFICATIONS

Item	Specifications
Operating temperature range	-55°C to +85°C
Current rating	AC 0.5A (signal) AC 1A (ground)
Max. allowable voltage	AC 30
Contact resistance (20m VDC 10mA)	80 m ohms max. (signal) 45 m ohms max.(ground)
Insulation resistance	1000M ohms minimum
Dielectric withstanding voltage	AC 500V for 1 minute
Durability	250 cycles
Insertion force	55.5 N max. (8 pair) 73 N max. (24 pair)
Withdrawl force	2.5 N min. (8 pair) 8 N min. (24 pair)

■ MATERIALS

Item	Materials
Insulator	LCP Resin (UL94V-0)
Conductor	Copper Alloy
Plating	Contact: Gold Plating (PAGOS) Terminal: Gold coat over Pd-Ni plating Cover: Zinc

Product Specification are subject to change, please check our website (<http://us.fujitsu.com/connectors>) for the latest specifications.

microGiGaCN™ FCN-260 (D) Series

The MicroGigaCN offers a cost-effective I/O solution for high-speed applications in data and telecommunications convergence (voice, data, video and storage). It offers four or twelve link widths, offering a scalable performance range of 500Mbps to 6Gbps per link to meet the needs of entry-level and high-end enterprise systems. Forward crosstalk is less than 4% at 100 pico second pulse-rise time (four-pair switching).

Fujitsu Components designed the MicroGiGaCN to specifically address the requirements for a high speed differential signal I/O connector.

The MicroGiGaCN offers a unique solution to LVDS, InfiniBand, 10G Ethernet, 3G/6G SAS & SATA, and other high speed I/O applications. InfiniBand, IEEE802.3ak, SAS, & SATA have selected Fujitsu's connector for the 4x and 12x I/O connector interface.

The performance requirements of the connector system were tested with cable to simulate the actual requirements of an OEM System manufacturer. Our test data includes the parasitic effects of the PCB, along with measurements of a completed I/O cable assembly.

Electrical Performance in out testing:

- Matched Impedance: 100±10 ohms @ 100 ps Trise
- Low Cross Talk: NEXT 4.0% @ 100pc Trise (20 to 80%)
- Low Insertion Loss: 2.3dB @ 2.5Gbps (1.25GHz, 1 meter Cable Assembly)
- Skew within Differential Pair: 14.4ps (2 connectors and 2 meter of cable)
- Skew pair to pair: 21.2ps (2 connectors and 2 meter of cable)

Connection

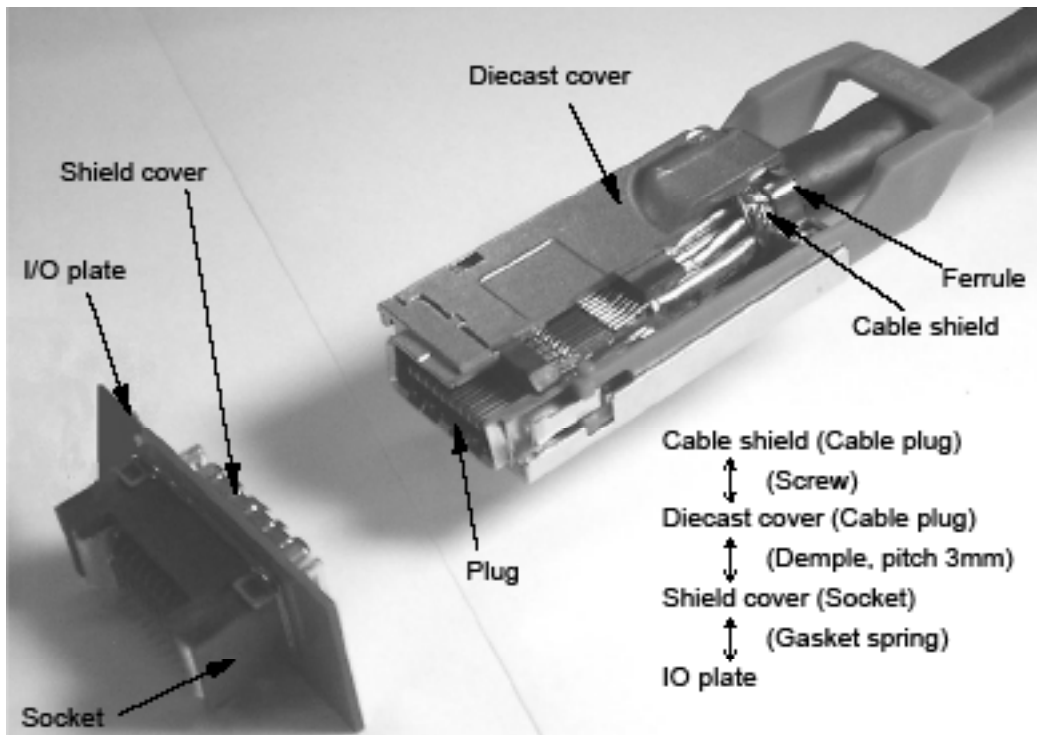

microGiGaCN™ FCN-260 (D) Series

Basic Concept for Differential Transfer

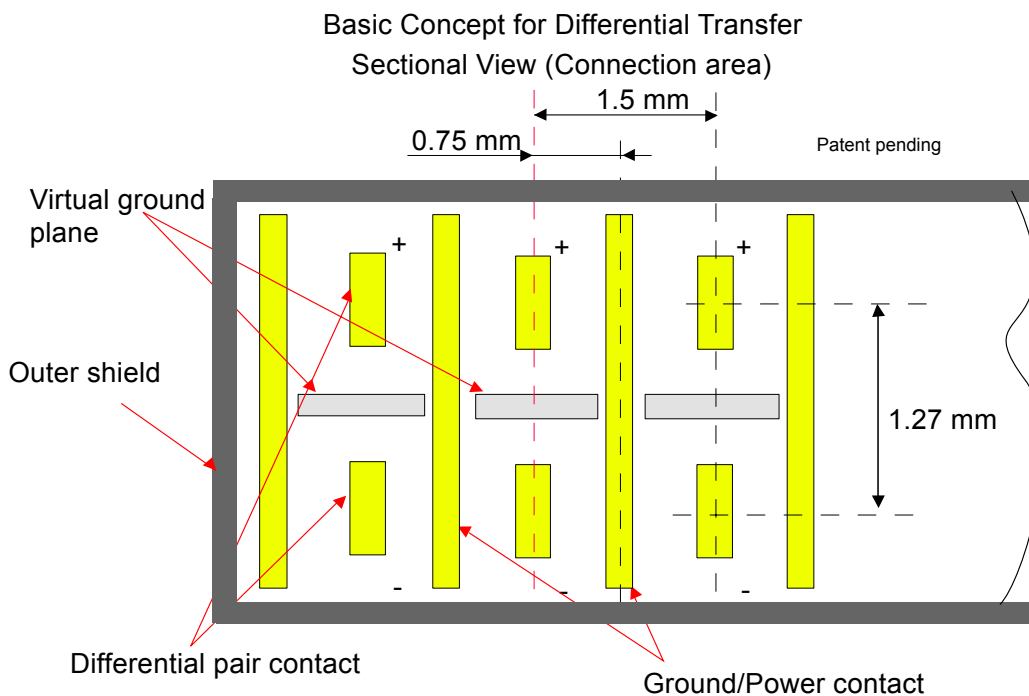

Product Specification are subject to change, please check our website (<http://us.fujitsu.com/connectors>) for the latest specifications.

Fujitsu Components has designed the mechanical features of the connector to provide space saving footprint that will allow for 3 4x I/O connectors to mount onto a PCI form, or 2 12x. As RFI/EMI are critical elements in high performance cable assemblies, Fujitsu Components provides the surface mount sockets with an EMI Ground Spring on the face of the connector, to insure that the metal surface of the connector makes sufficient contact with the metal face of the card bracket.

The latching mechanism of the backshell offers a lanyard system for ease of un-mating the I/O plug connector/cable assembly from the SMT I/O socket. The die cast backshell offers excellent RFI/EMI characteristics. The backshell uses a ferrule and

unique ground spring system to provide 360 degree contact of the cable shield to the backshell, which, combined with the solid interconnect of the socket to faceplate, offers low AC coupling termination.

The current version of the I/O plug comes with an attached paddlecard for wire termination. Fujitsu offers the paddlecard in either an equalized or un-equalized version (see factory for details of the equalized version). Standard product offering will be un-equalized. As there are multiple applications for the paddlecard, with industry and customer specific wire termination, Fujitsu Components offers options to customers of providing the I/O plug connector with custom paddlecards (consult factory).

microGiGaCN™ FCN-260 (D) Series

CABLE I/O JACK SCREW LOCK TYPE - WITH ALIGNMENT PIN / WITH CRUSH PIN

■ DIMENSIONS

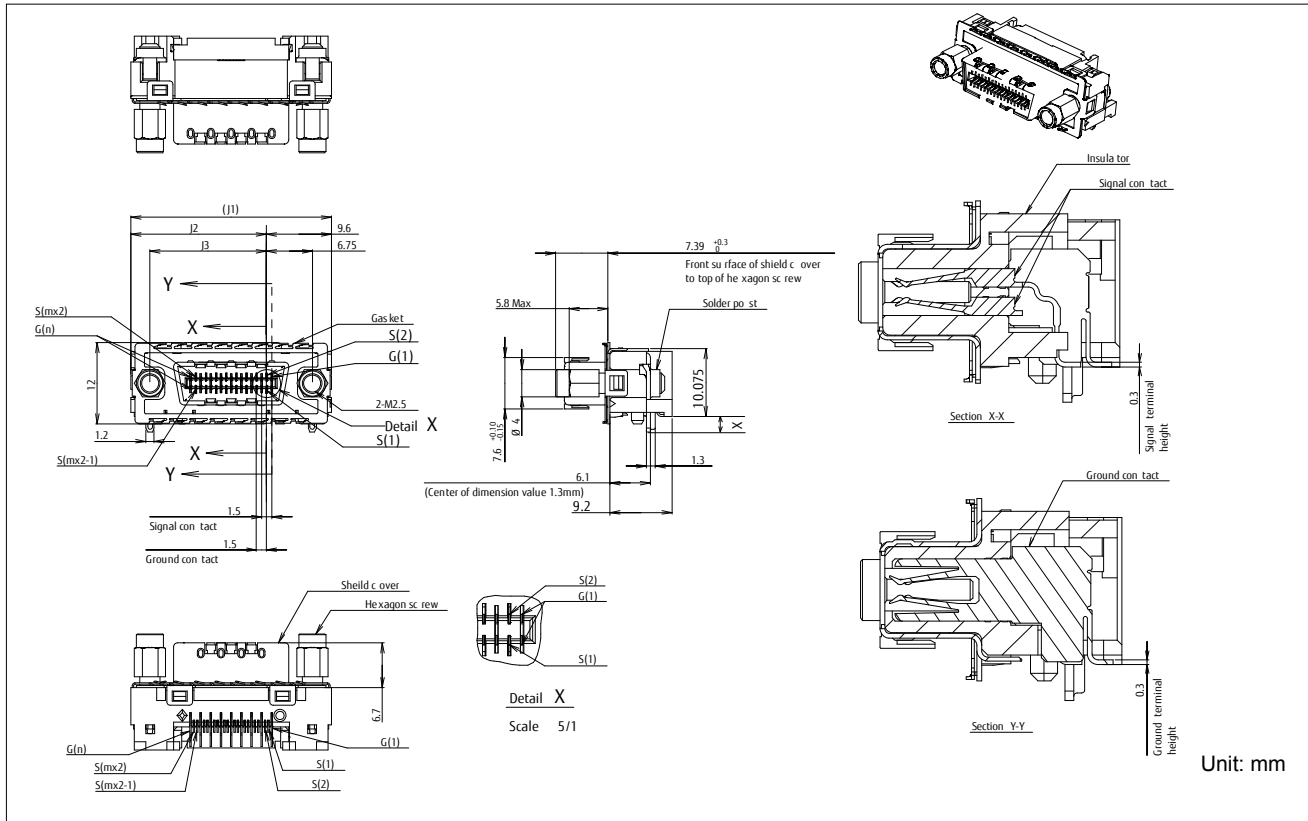

■ RECOMMENDED PCP LAYOUT

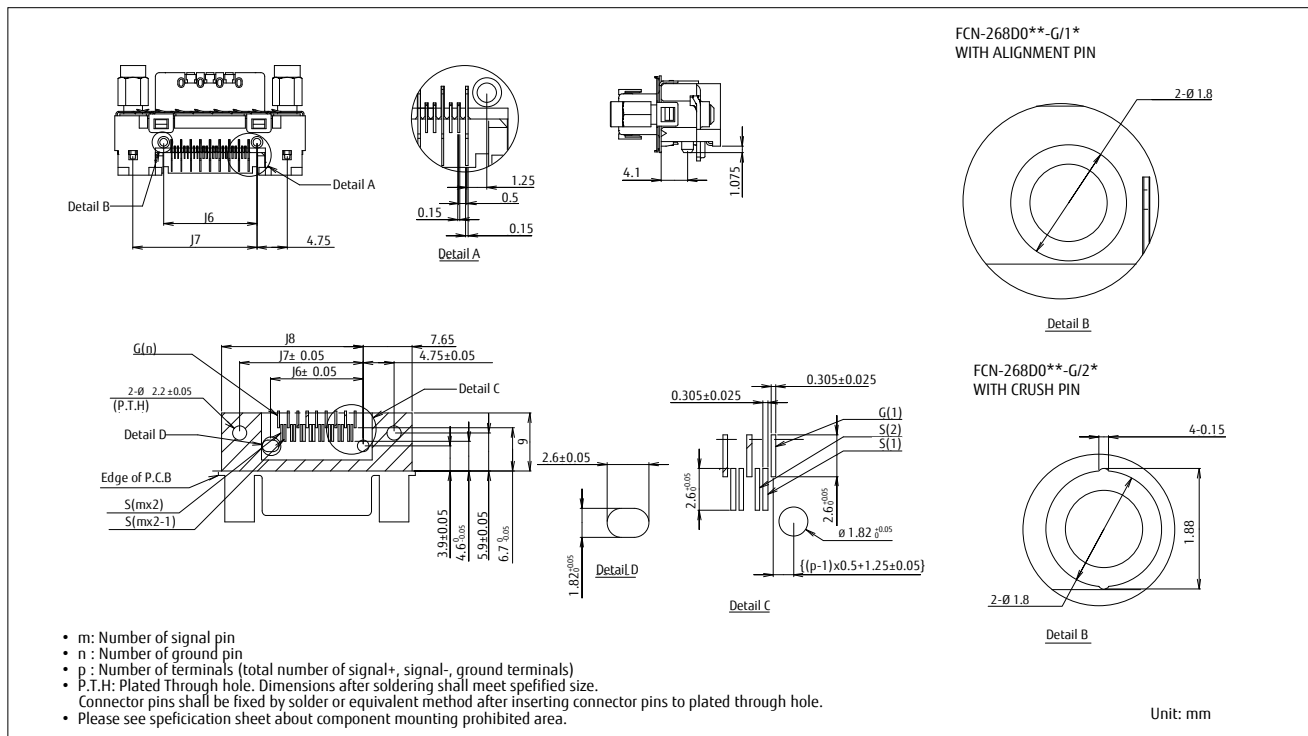

- m: Number of signal pin
- n: Number of ground pin
- p: Number of terminals (total number of signal+, signal-, ground terminals)
- P.T.H: Plated Through hole. Dimensions after soldering shall meet specified size.
- Connector pins shall be fixed by solder or equivalent method after inserting connector pins to plated through hole.
- Please see specification sheet about component mounting prohibited area.

microGiGaCN™ FCN-260 (D) Series

CABLE I/O JACK SCREW LOCK TYPE - WITH DIAMOND PIN

■ DIMENSIONS / RECOMMENDED PCP LAYOUT

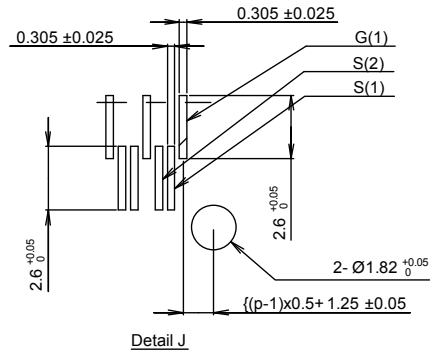
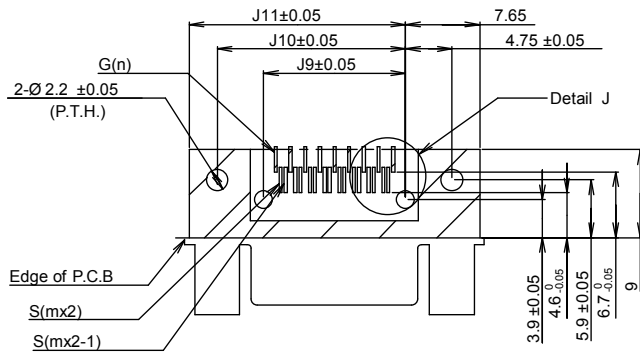
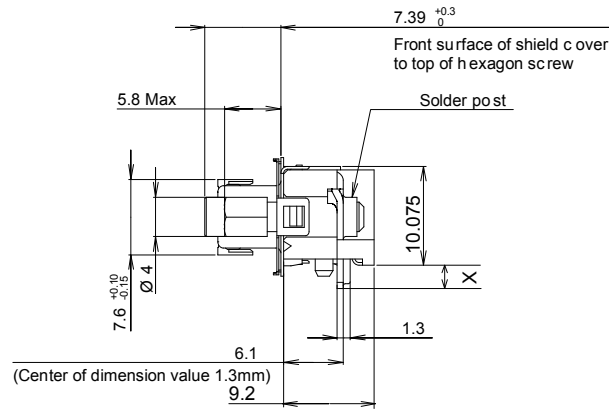
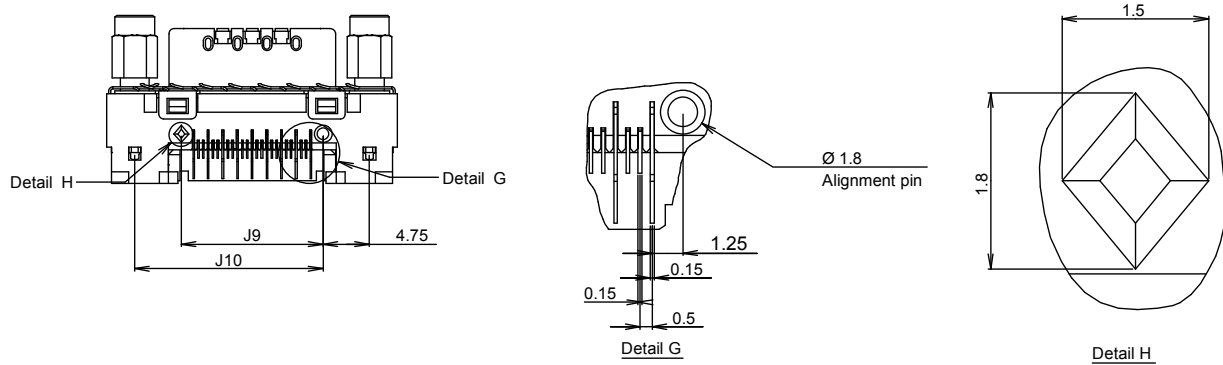

- m: Number of signal pin
- n : Number of ground pin
- p : Number of terminals (total number of signal+, signal-, ground terminals)
- P.T.H: Plated Through hole. Dimensions after soldering shall meet specified size.
- Connector pins shall be fixed by solder or equivalent method after inserting connector pins to plated through hole.
- Please see specification sheet about component mounting prohibited area.

microGiGaCN™ FCN-260 (D) Series

CABLE I/O JACK SCREW LOCK TYPE FCN-268D0**-G/ ** PANEL CUTOUT (REFERENCE)

■ DIMENSIONS

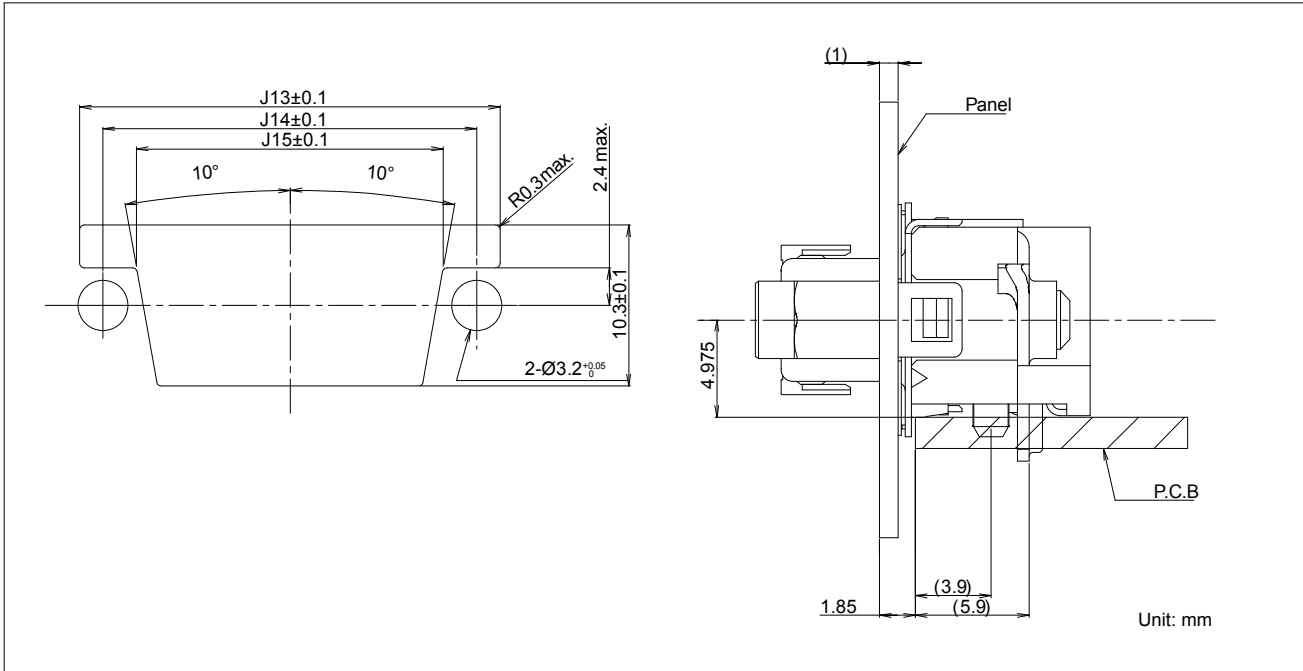

■ PART NUMBERS

Part Number	Dimensions (mm)		
	J13	J14	J15
FCN-264D008-G/**	27	24	19.7
FCN-264D024-G/**	51	48	43.7

microGiGaCN™ FCN-260 (D) Series

CABLE I/O JACK SCREW LOCK TYPE - WITH ALIGNMENT PIN / WITH CRUSH PIN

■ PART NUMBERS

FCN-268D**-G/1 with alignment pin

Part Number	Pair	PCB thickness (mm)	Dimensions (mm)						
			X	J1	J2	J3	J6	J7	J8
FCN-268D008-G/10	8	1.6	2.325	29.8	20.15	17.25	14.5	19.25	22.15
FCN-268D008-G/11		2.4	3.125	29.8	20.15	17.25	14.5	19.25	22.15
FCN-268D008-G/13		4.0	4.725	29.8	20.15	17.25	14.5	19.25	22.15
FCN-268D024-G/10	24	1.6	2.325	53.8	44.15	41.25	38.5	43.25	46.15
FCN-268D024-G/11		2.4	3.125	53.8	44.15	41.25	38.5	43.25	46.15
FCN-268D024-G/13		4.0	4.725	53.8	44.15	41.25	38.5	43.25	46.15

■ PART NUMBERS

FCN-268D**-G/2 with crush pin

Part Number	Pair	PCB thickness (mm)	Dimensions (mm)						
			X	J1	J2	J3	J6	J7	J8
FCN-268D008-G/20	8	1.6	2.325	29.8	20.15	17.25	14.5	19.25	22.15
FCN-268D008-G/21		2.4	3.125	29.8	20.15	17.25	14.5	19.25	22.15
FCN-268D008-G/23		4.0	4.725	29.8	20.15	17.25	14.5	19.25	22.15
FCN-268D024-G/20	24	1.6	2.325	53.8	44.15	41.25	38.5	43.25	46.15
FCN-268D024-G/21		2.4	3.125	53.8	44.15	41.25	38.5	43.25	46.15
FCN-268D024-G/23		4.0	4.725	53.8	44.15	41.25	38.5	43.25	46.15

■ PART NUMBERS

FCN-268D**-G/3 with diamond pin

Part Number	Pair	PCB thickness (mm)	Dimensions (mm)			
			X	J9	J10	J11
FCN-268D008-G/30	8	1.6	2.325	14.5	19.25	22.15
FCN-268D008-G/31		2.4	3.125	14.5	19.25	22.15
FCN-268D008-G/33		4.0	4.725	14.5	19.25	22.15
FCN-268D024-G/30	24	1.6	2.325	38.5	43.25	46.15
FCN-268D024-G/31		2.4	3.125	38.5	43.25	46.15
FCN-268D024-G/33		4.0	4.725	38.5	43.25	46.15

microGiGaCN™ FCN-260 (D) Series

FCN-264D - VERTICAL MOUNT SOCKETS, LATCH STYLE

■ DIMENSIONS

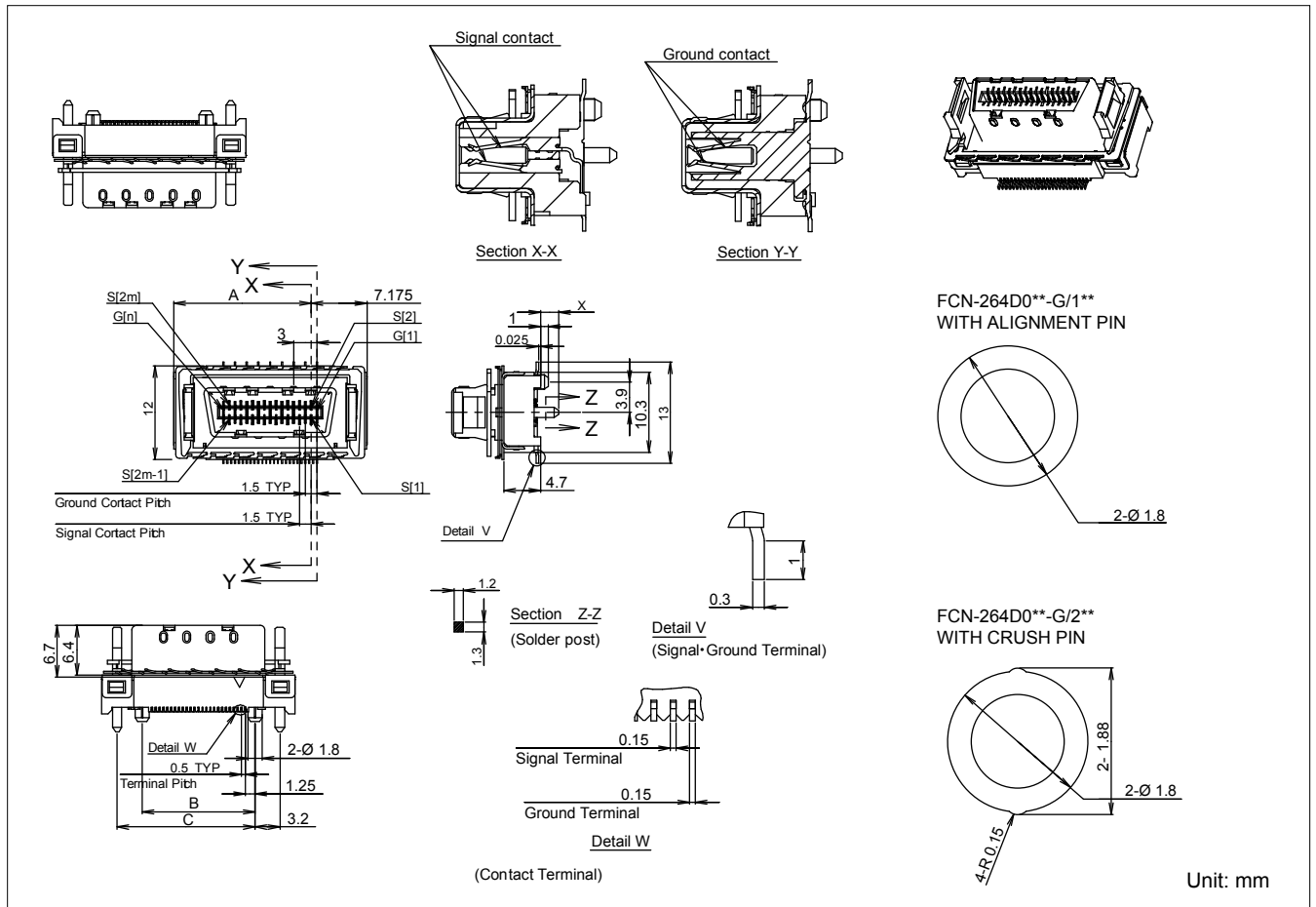

■ RECOMMENDED PCB LAYOUT (TOP VIEW)

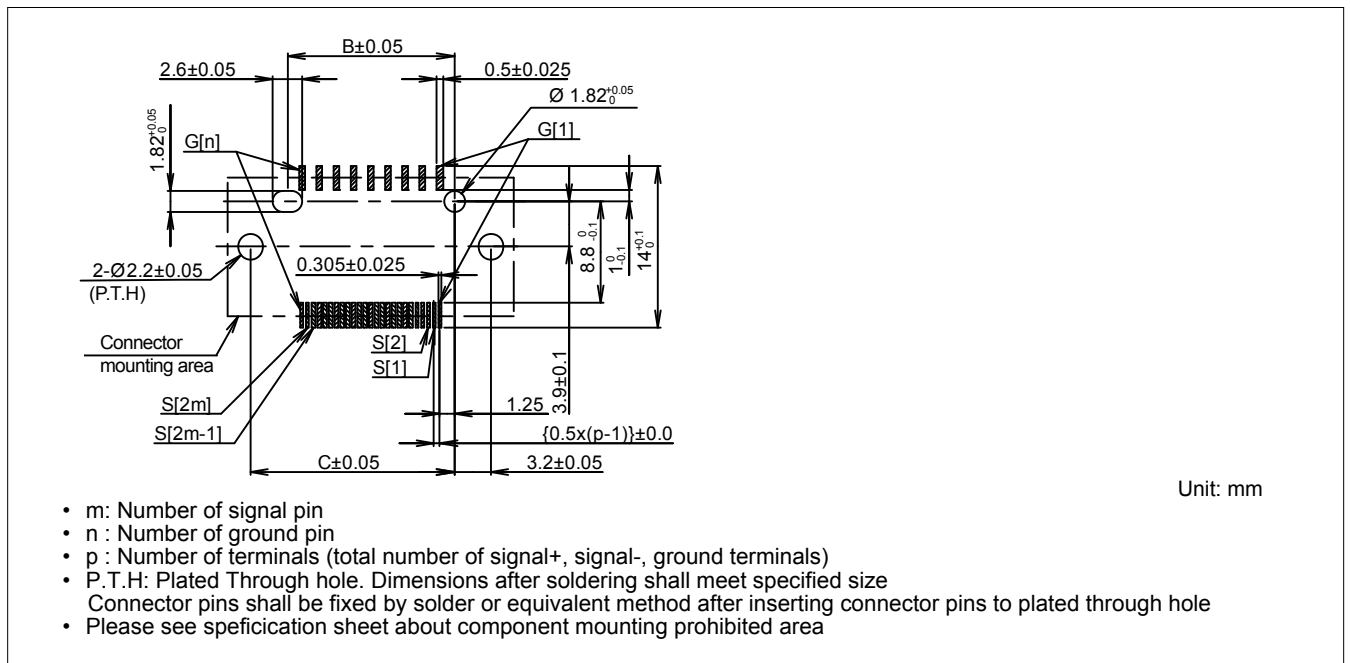

microGiGaCN™ FCN-260 (D) Series

FCN-264D - VERTICAL MOUNT SOCKETS, LATCH STYLE

■ PART NUMBERS

FCN-264D**-G/1 with alignment pin

Part Number	Pair	PCB thickness (mm)	Dimensions (mm)			
			X	A	B	C
FCN-264D008-G/1D	8	1.6	2.325	17.675	14.5	17.7
FCN-264D008-G/1F		2.4	3.125	17.675	14.5	17.7
FCN-264D008-G/1K		4.0	4.725	17.675	14.5	17.7
FCN-264D024-G/1D	24	1.6	2.325	41.675	38.5	41.7
FCN-264D024-G/1F		2.4	3.125	41.675	38.5	41.7
FCN-264D024-G/1K		4.0	4.725	41.675	38.5	41.7

■ PART NUMBERS

FCN-264D**-G/2 with crush pin

Part Number	Pair	PCB thickness (mm)	Dimensions (mm)			
			X	A	B	C
FCN-264D008-G/2D	8	1.6	2.325	17.675	14.5	17.7
FCN-264D008-G/2F		2.4	3.125	17.675	14.5	17.7
FCN-264D008-G/2K		4.0	4.725	17.675	14.5	17.7
FCN-264D024-G/2D	24	1.6	2.325	41.675	38.5	41.7
FCN-264D024-G/2F		2.4	3.125	41.675	38.5	41.7
FCN-264D024-G/2K		4.0	4.725	41.675	38.5	41.7

■ RECOMMENDED FOOTPRINT DIMENSIONS

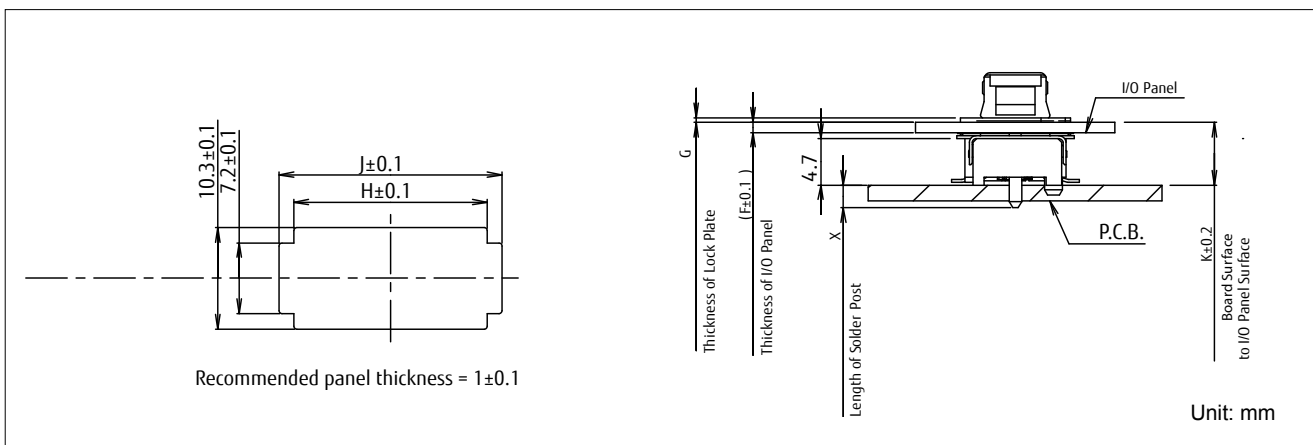

■ PART NUMBERS

Part Number	Dimensions (mm)					Retention Clip Part Number
	J	K	N (Panel thickness)	P (Lock plate thickness)	K	
FCN-264D008-G/**	19.7	22.7	1.0	0.5	6.35	FCN-260A622
FCN-264D024-G/**	43.2	46.7	1.0	0.5	6.34	FCN-260A626

microGiGaCN™ FCN-260 (D) Series

4X / 12X RIGHT ANGLE MOUNT SOCKETS WITH LATCHES

■ DIMENSIONS

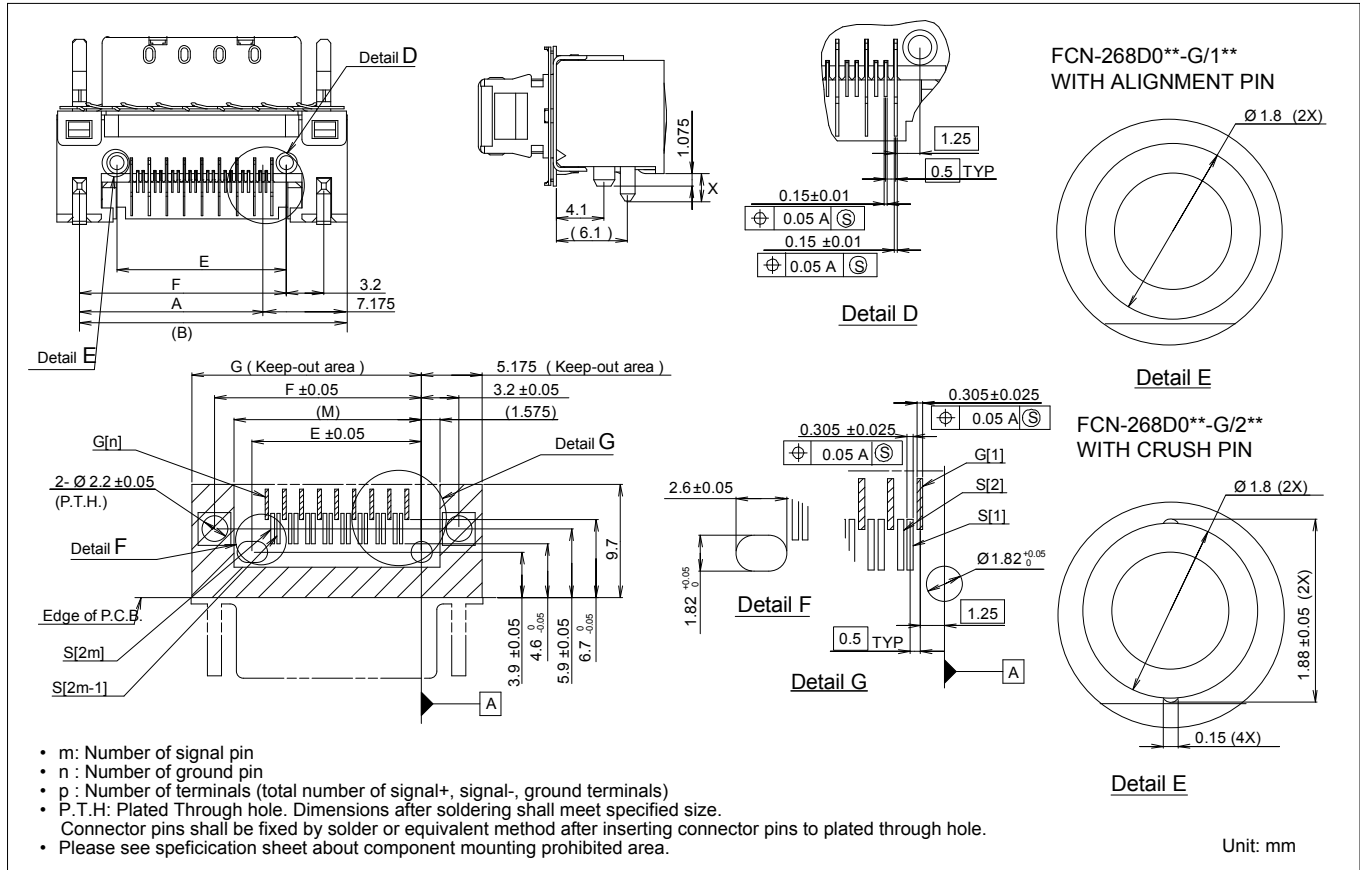

■ RECOMMENDED PANEL LAYOUT

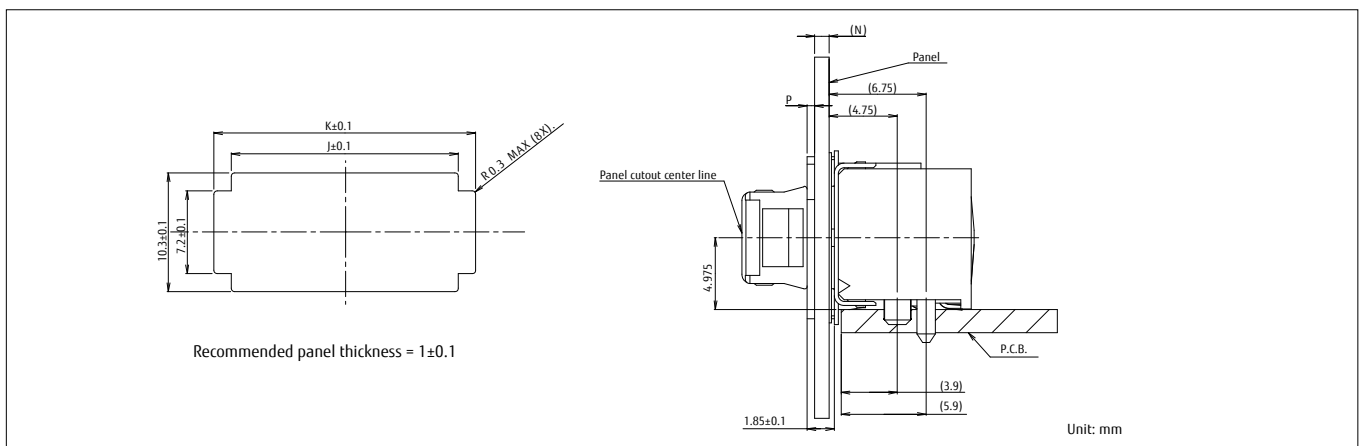

■ PART NUMBERS

Part Number	Dimensions (mm)				Retention Clip Part Number
	J	K	N (Panel thickness)	P (Lock plate thickness)	
FCN-268D008-G/**	19.7	22.7	1.0	0.5	FCN-260A622
FCN-268D024-G/**	43.2	46.7	1.0	0.5	FCN-260A626

microGiGaCN™ FCN-260 (D) Series

4X / 12X RIGHT ANGLE MOUNT SOCKETS WITH LATCHES WITH ALIGNMENT POST OR CRUSH PIN OPTION

■ PART NUMBERS

FCN-268D**-G/1 with alignment pin

Part Number	Pair	PCB thickness (mm)	Dimensions (mm)						
			X	A	B	E	F	G	M
FCN-268D008-G/1D	8	1.6	2.325	17.675	24.85	14.5	17.7	19.675	16.075
FCN-268D008-G/1F		2.4	3.125	17.675	24.85	14.5	17.7	19.675	16.075
FCN-268D008-G/1K		4.0	4.725	17.675	24.85	14.5	17.7	19.675	16.075
FCN-268D024-G/1D	24	1.6	2.325	41.675	48.85	38.5	41.7	43.675	40.075
FCN-268D024-G/1F		2.4	3.125	41.675	48.85	38.5	41.7	43.675	40.075
FCN-268D024-G/1K		4.0	4.725	41.675	48.85	38.5	41.7	43.675	40.075

■ PART NUMBERS

FCN-268D**-G/2 with crush pin

Part Number	Pair	PCB thickness (mm)	Dimensions (mm)						
			X	A	B	E	F	G	M
FCN-268D008-G/2D	8	1.6	2.325	17.675	24.85	14.5	17.7	19.675	16.075
FCN-268D008-G/2F		2.4	3.125	17.675	24.85	14.5	17.7	19.675	16.075
FCN-268D008-G/2K		4.0	4.725	17.675	24.85	14.5	17.7	19.675	16.075
FCN-268D024-G/2D	24	1.6	2.325	41.675	48.85	38.5	41.7	43.675	40.075
FCN-268D024-G/2F		2.4	3.125	41.675	48.85	38.5	41.7	43.675	40.075
FCN-268D024-G/2K		4.0	4.725	41.675	48.85	38.5	41.7	43.675	40.075

Retention Clip Hand Tool



FCN-268T-T514/H

For Assembly instructions, please see the Lock Plate Hand Tool Instruction Manual

Retention Clip

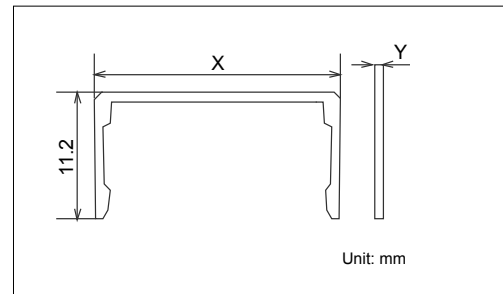

Each connector is shipped with 1 piece of FCN-260A622 (8-pair) or FCN-260A626 (24-pair) retention clip. To order connector and retention clip separately, please contact sales for part number.

■ PART NUMBERS

Part Number	Pair	Dimensions (mm)		Panel thickness (mm)
		X	Y	
FCN-260A622	8	23.45	0.5	1.0
FCN-260A626	24	47.45	0.5	1.0

microGiGaCN™ FCN-260 (D) Series

4X / 12X RIGHT ANGLE MOUNT CONNECTOR SOCKET WITH LATCHES WITH MOUNTING EARS

■ DIMENSIONS

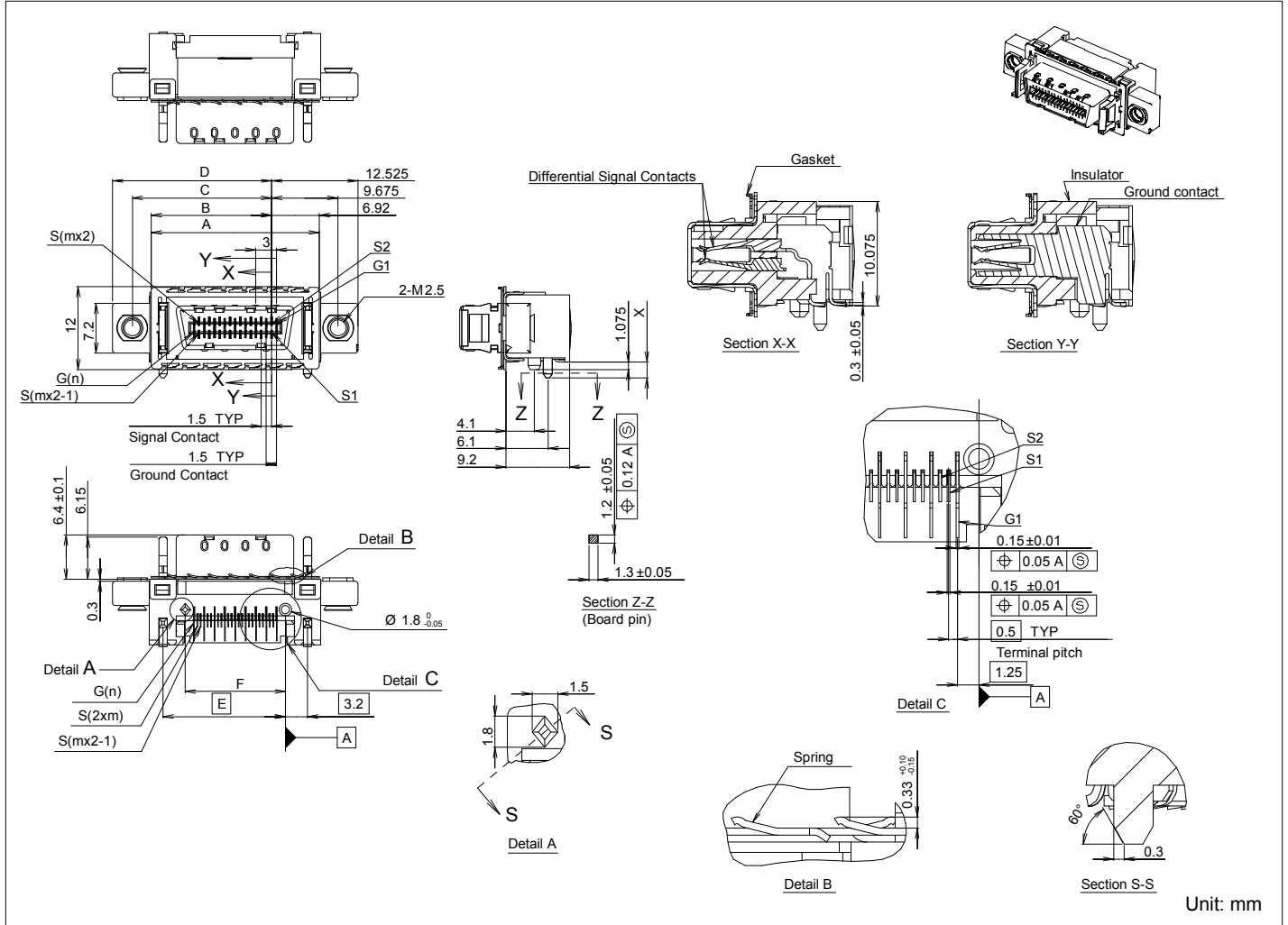

■ RECOMMENDED PCB LAYOUT (TOP VIEW)

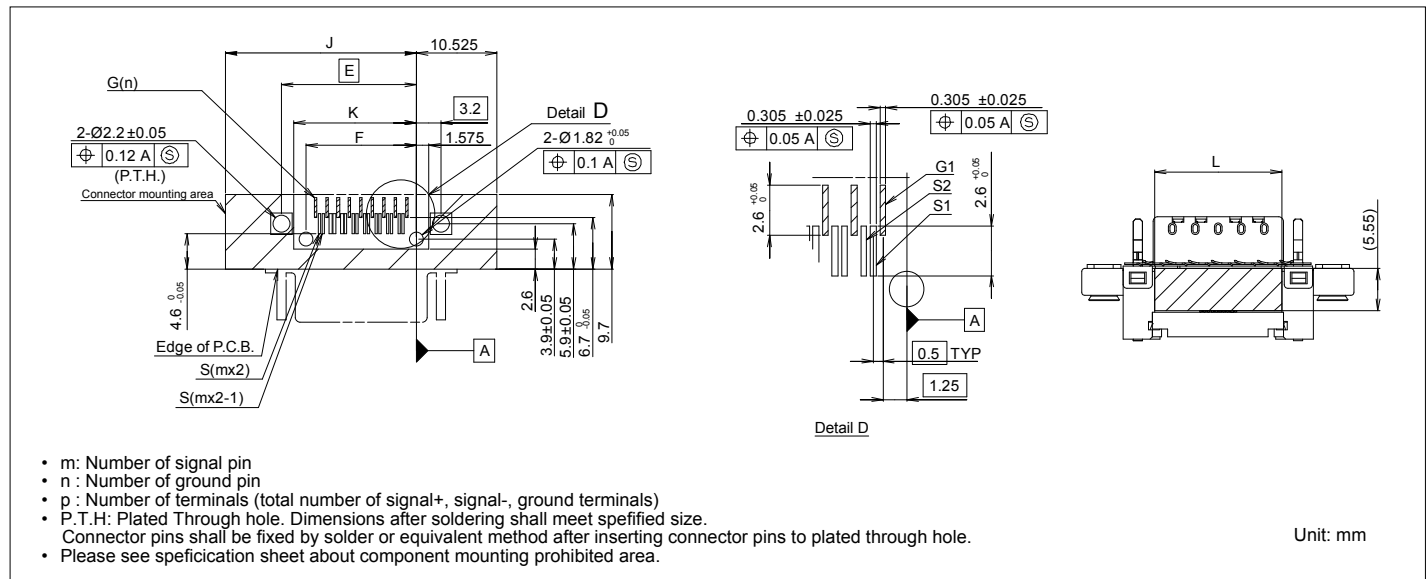

- m: Number of signal pin
- n: Number of ground pin
- p: Number of terminals (total number of signal+, signal-, ground terminals)
- P.T.H: Plated Through hole. Dimensions after soldering shall meet specified size.
Connector pins shall be fixed by solder or equivalent method after inserting connector pins to plated through hole.
- Please see specification sheet about component mounting prohibited area.

microGiGaCN™ FCN-260 (D) Series

4X / 12X RIGHT ANGLE MOUNT CONNECTOR SOCKET WITH LATCHES, WITH MOUNTING EARS

■ PART NUMBERS

Part Number	Pair	PCB thickness (mm)	Dimensions (mm)									
			X	A	B	C	D	E	F	J	K	L
FCN-268D008-G/3L-R	8	1.6	2.4	24.34	17.42	20.175	23.025	17.7	14.5	25.025	16.075	16.65
FCN-268D008-G/3M-R		2.4	3.2	24.34	17.42	20.175	23.025	17.7	14.5	25.025	16.075	16.65
FCN-268D008-G/3P-R		4.0	4.8	24.34	17.42	20.175	23.025	17.7	14.5	25.025	16.075	16.65
FCN-268D024-G/3L-R	24	1.6	2.4	48.34	41.42	44.175	47.025	41.7	38.5	49.025	38.075	40.65
FCN-268D024-G/3M-R		2.4	3.2	48.34	41.42	44.175	47.025	41.7	38.5	49.025	38.075	40.65
FCN-268D024-G/3P-R		4.0	4.8	48.34	41.42	44.175	47.025	41.7	38.5	49.025	38.075	40.65

■ RECOMMENDED FOOTPRINT DIMENSIONS

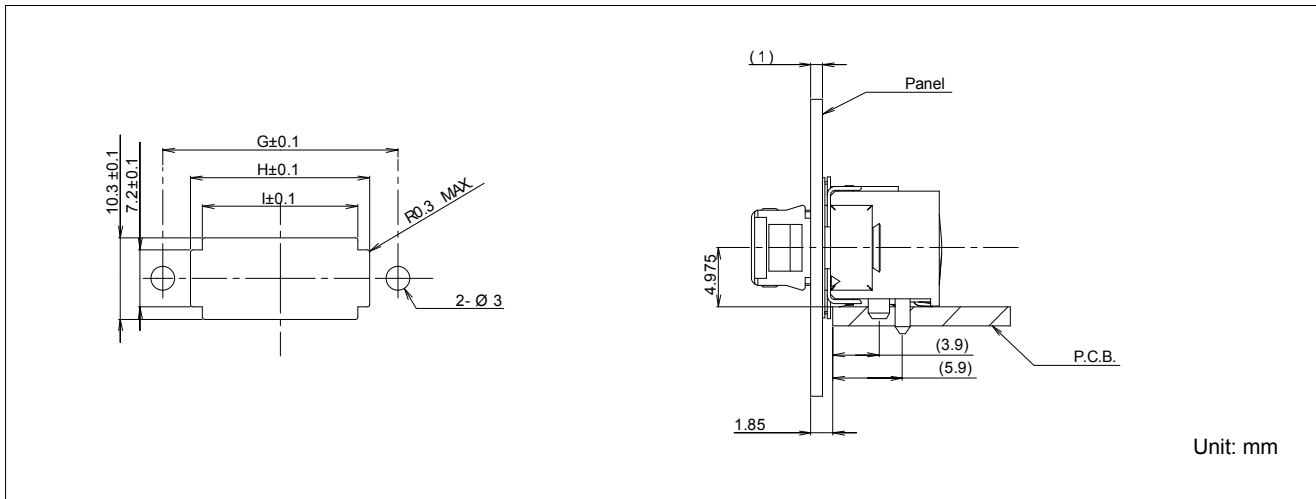

■ PART NUMBERS

Part Number	Dimensions (mm)		
	G	H	I
FCN-268D008-G/3*-R	29.85	22.7	19.7
FCN-268D024-G/3*-R	53.85	46.7	43.7

microGiGaCN™ FCN-260 (D) Series

4X / 12X PLUG CONNECTOR WITH INFINIBAND STYLE PCB

■ REFERENCE

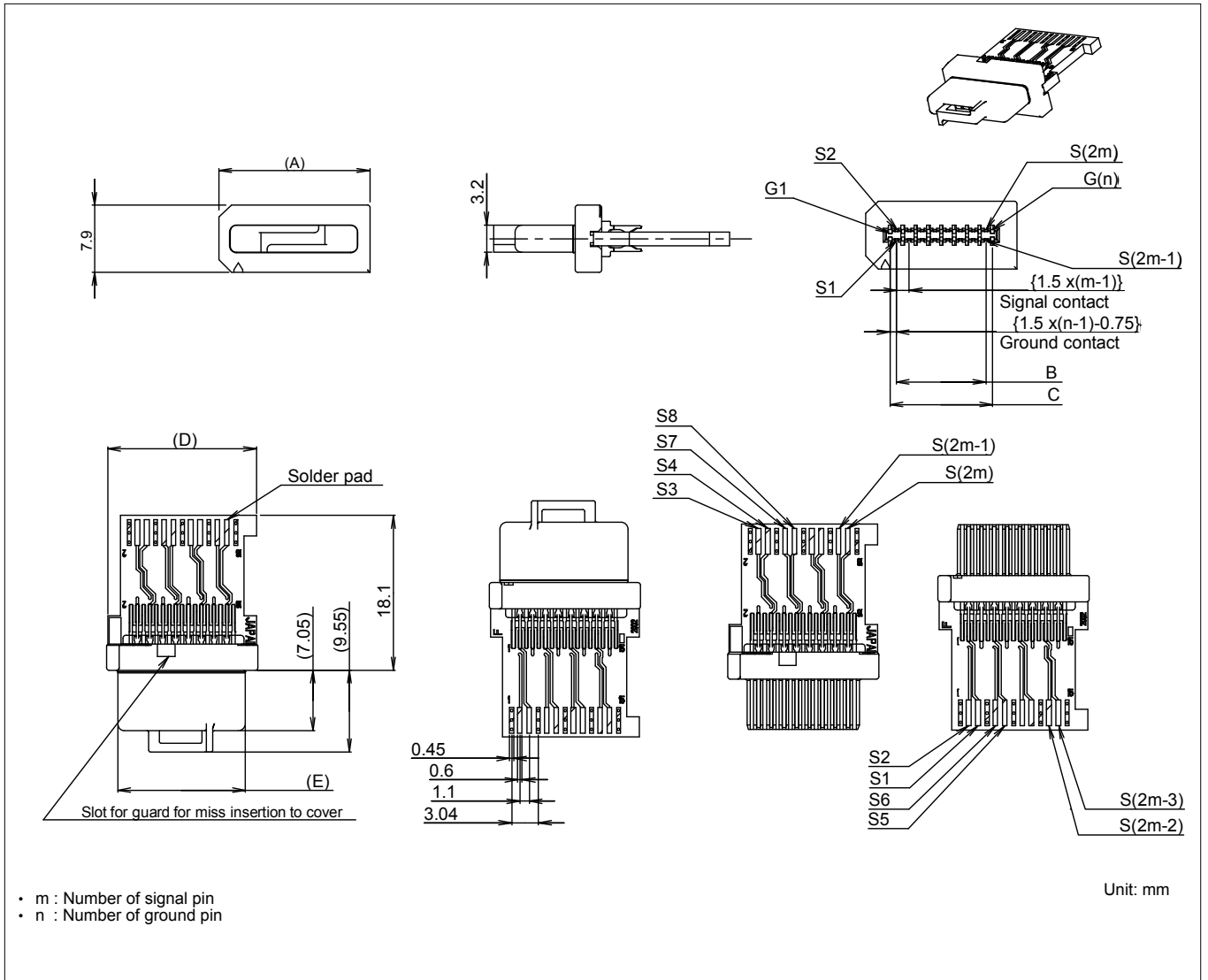

■ PART NUMBERS

Part Number	Pair	Dimensions (mm)				
		A	B	C	D	E
FCN-261R008-G/5L	8	17.7	10.5	12.0	17.4	14.95
FCN-261R024-G/5L	24	41.7	34.5	36.0	41.4	38.95

microGiGaCN™ FCN- 260 (D) Series

4X / 12X PLUG CONNECTOR WITH INFINIBAND STYLE PCB (CABLE MOUNT)

■ PART NUMBERS

Non-Equalized Plug Kits

RoHS 6/6	Data Speeds
FCN-261R008-G/0L	4x up to 3.2Gbps
FCN-261R008-G/5L	4x up to 5Gbps
FCN-261R024-G/0L	12x up to 3.2Gbps
FCN-261R024-G/5L	12x up to 5Gbps

Equalized Plug Kits

4x Plug Kits - Equalized

RoHS 6/6 (lead free solder)	Data Speeds	Equalized Pair
FCN-261R008-G/6L#08	IB DDR 8 meter, 24AWG	1-4
FCN-261R008-G/6L#10	IB DDR 10 meter, 24AWG	1-4
FCN-261R008-G/6L#12	IB DDR 12 meter, 24AWG	1-4
FCN-261R008-G/6M#08	IB DDR 8 meter, 26AWG	1-4
FCN-261R008-G/6M#10	IB DDR 10 meter, 26AWG	1-4
FCN-261R008-G/6M#12	IB DDR 12 meter, 26AWG	1-4

12x Plug Kits - Equalized

RoHS 6/6 (lead free solder)	Data Speeds	Equalized Pair
FCN-261R024-G/6L#08	12x IB DDR 8 meter, 24AWG	1-12
FCN-261R024-G/6L#10	12x IB DDR 10 meter, 24AWG	1-12
FCN-261R024-G/6L#12	12x IB DDR 12 meter, 24AWG	1-12
FCN-261R024-G/6M#08	12x IB DDR 8 meter, 26AWG	1-12
FCN-261R024-G/6M#10	12x IB DDR 10 meter, 26AWG	1-12
FCN-261R024-G/6M#12	12x IB DDR 12 meter, 26AWG	1-12

IB SDR = InfiniBand Single Data rate - 2.5Gbps

IB DDR = InfiniBand Double Data rate - 5Gbps

Equalized circuits are optimized for cable length / wire AWG

microGiGaCN™ FCN-260 (D) Series

4X / 12X PLUG CONNECTOR WITHOUT PCB RECOMMENDED PADDLE CARD OUTLINE

■ DIMENSIONS

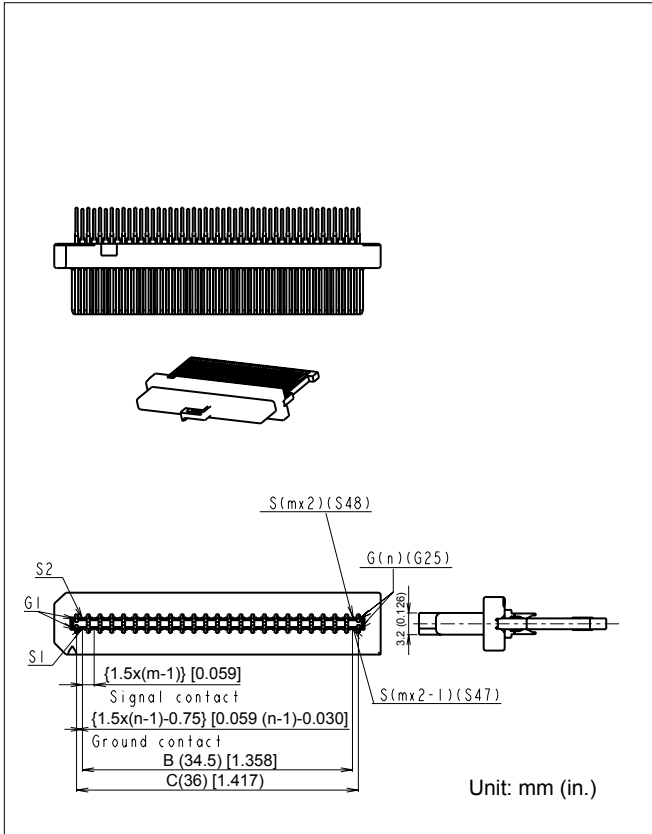

■ PART NUMBERS

Part Number	Pair	m	n	B	C
FCN-261R008-G/A	8	1-8	1-9	10.5 (0.413)	12.0 (0.472)
FCN-261R024-G/A	12	1-24	1-25	34.5 (1.358)	36.0 (1.417)

microGiGaCN™ FCN-260 (D) Series

4X I/O CABLE ASSEMBLY (LATCH/THUMB SCREW) CONFORMS TO IBTA DDR / 100GBASE-CX4

■ PART NUMBERS

Conforming Standard
IB DDR (5Gbps)

Type	Cable	Cable length	Part Number
Latch	26AWG	1m	FCD-ZZ26001
		2m	FCD-ZZ26002
		3m	FCD-ZZ26003
		5m	FCD-ZZ26004
	28AWG	1m	FCD-ZZ26011
		2m	FCD-ZZ26012
		3m	FCD-ZZ26013
	30AWG	1m	FCD-ZZ26021
		2m	FCD-ZZ26022
		3m	FCD-ZZ26023
Thumb screw	26AWG	1m	FCD-ZZ27001
		2m	FCD-ZZ27002
		3m	FCD-ZZ27003
		5m	FCD-ZZ27004
	28AWG	1m	FCD-ZZ27011
		2m	FCD-ZZ27012
		3m	FCD-ZZ27013
	30AWG	1m	FCD-ZZ27021
		2m	FCD-ZZ27022
		3m	FCD-ZZ27023

Conforming Standard
10GBASE-CX4 (3.215 Gbps)

Type	Cable	Cable length	Part Number	
Latch	26AWG	1m	FCD-ZZ22001	
		2m	FCD-ZZ22002	
		3m	FCD-ZZ22003	
		5m	FCD-ZZ22004	
		7m	FCD-ZZ22005	
		10m	FCD-ZZ22006	
	28AWG	1m	FCD-ZZ22011	
		2m	FCD-ZZ22012	
		3m	FCD-ZZ22013	
		5m	FCD-ZZ22014	
		7m	FCD-ZZ22015	
		10m	FCD-ZZ22016	
	30AWG	1m	FCD-ZZ22021	
		2m	FCD-ZZ22022	
		3m	FCD-ZZ22023	
		5m	FCD-ZZ22024	
	Thumb Screw	26AWG	1m	FCD-ZZ23001
			2m	FCD-ZZ23002
			3m	FCD-ZZ23003
			5m	FCD-ZZ23004
			7m	FCD-ZZ23005
			10m	FCD-ZZ23006
		28AWG	1m	FCD-ZZ23011
			2m	FCD-ZZ23012
3m			FCD-ZZ23013	
5m			FCD-ZZ23014	
7m			FCD-ZZ23015	
10m			FCD-ZZ23016	
30AWG		1m	FCD-ZZ23021	
		2m	FCD-ZZ23022	
		3m	FCD-ZZ23023	
		5m	FCD-ZZ23024	

microGiGaCN™ FCN-260 (D) Series

4X I/O CABLE ASSEMBLY (LATCH/THUMB SCREW)
CONFORMS TO IBTA DDR / 100GBASE-CX4

■ DIMENSIONS LATCH TYPE 4X)

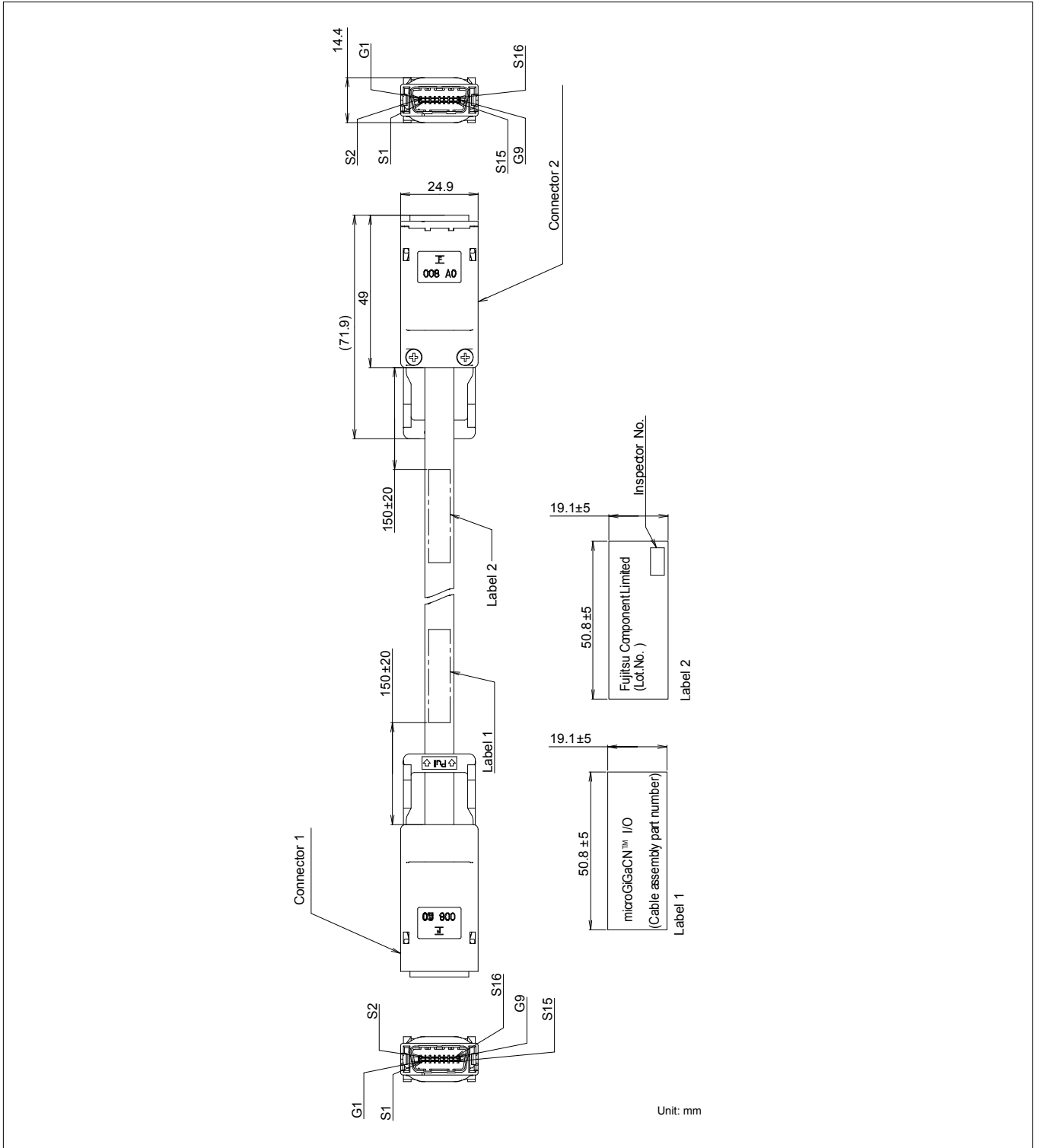

microGiGaCN™ FCN-260 (D) Series

4X / 12X BACKSHELL KITS, WITH LATCHES CABLE I/O PLUG COVER

■ DIMENSIONS

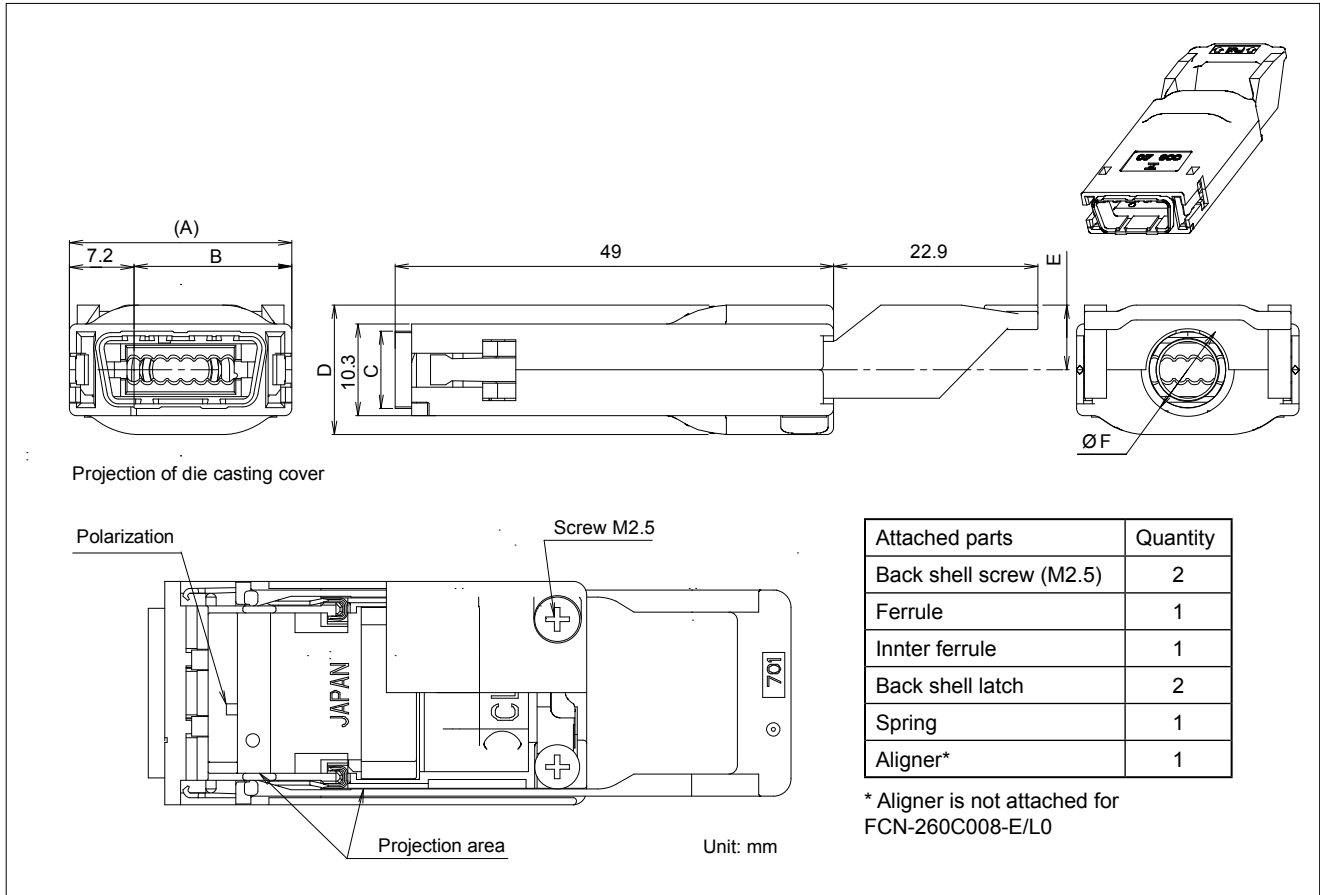

■ PART NUMBERS

Part Number	Pair	Cable	Dimensions (mm)					
			A	B	C	D	E	F
FCN-260C008-A/L0	8	24AWG	24.9	17.7	8.7	14.4	7.2	10.45
FCN-260C008-C/L0		26AWG	24.9	17.7	8.7	14.4	7.2	9.23
FCN-260C008-E/L0		28AWG	24.9	17.7	8.7	14.4	7.2	9.23
FCN-260C024-A/L0	24	24AWG	48.9	41.7	8.7	21.0	10.5	15.65
FCN-260C024-C/L0		26AWG	48.9	41.7	8.7	17.5	10.5	14.3
FCN-260C024-E/L0		28AWG	48.9	41.7	8.3	16.4	8.2	13.3

microGiGaCN™ FCN-260 (D) Series

4X LOOPBACK MODULE - 8 PAIRS

FCN-261Z008 (ROHS 5/6) - discontinued, replaced by:
FCN-261Z008L (ROHS 6/6)

■ DIMENSIONS

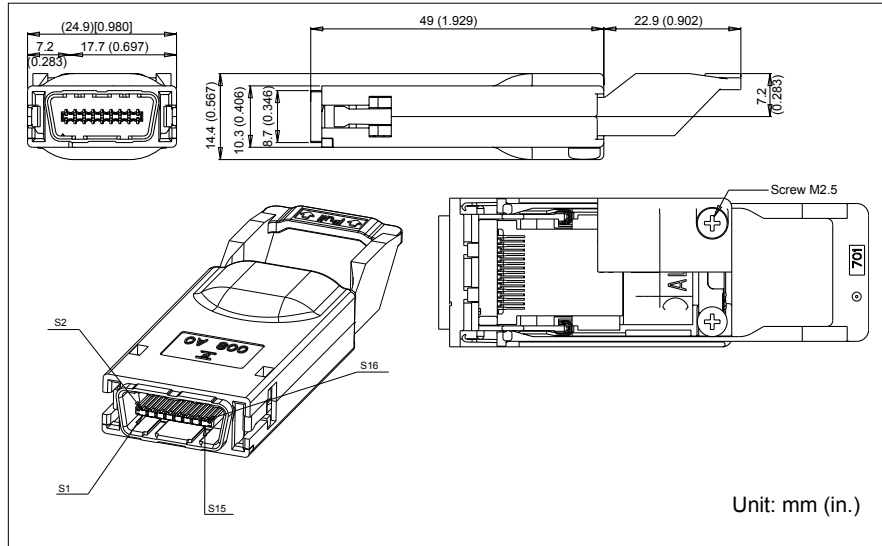

Pin Number	
From	To
S1	S16
S2	S15
S3	S14
S4	S13
S5	S12
S6	S11
S7	S10
S8	S9

■ PART NUMBER

Part Number	Pair
FCN-261Z008L	8

12X LOOPBACK MODULE - 24 PAIRS

FCN-261Z024 (ROHS 5/6)- discontinued, replaced by:
FCN-261Z024L (ROHS 6/6)

■ DIMENSIONS

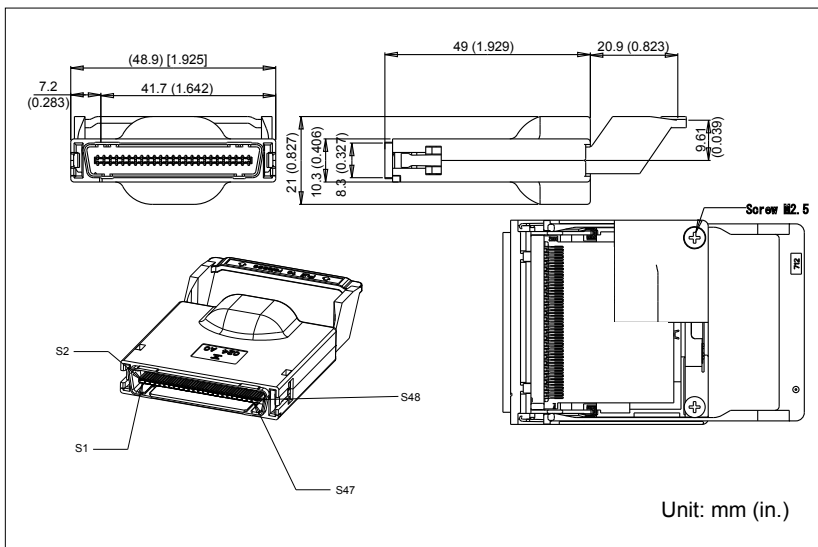

Pin Number		S12	S37
From	To		
S1	S48	S13	S36
S2	S47	S14	S35
S3	S46	S15	S34
S4	S45	S16	S33
S5	S44	S17	S32
S6	S43	S18	S31
S7	S42	S19	S30
S8	S41	S20	S29
S9	S40	S21	S28
S10	S39	S22	S27
S11	S38	S23	S26
		S24	S25

■ PART NUMBER

Part Number	Pair
FCN-261Z024L	24

microGiGaCN™ FCN-260 (D) Series

4X LOOPBACK MODULE - 8 PAIRS WITH THUMBSCREWS FCN-261Z008-SL

■ DIMENSIONS

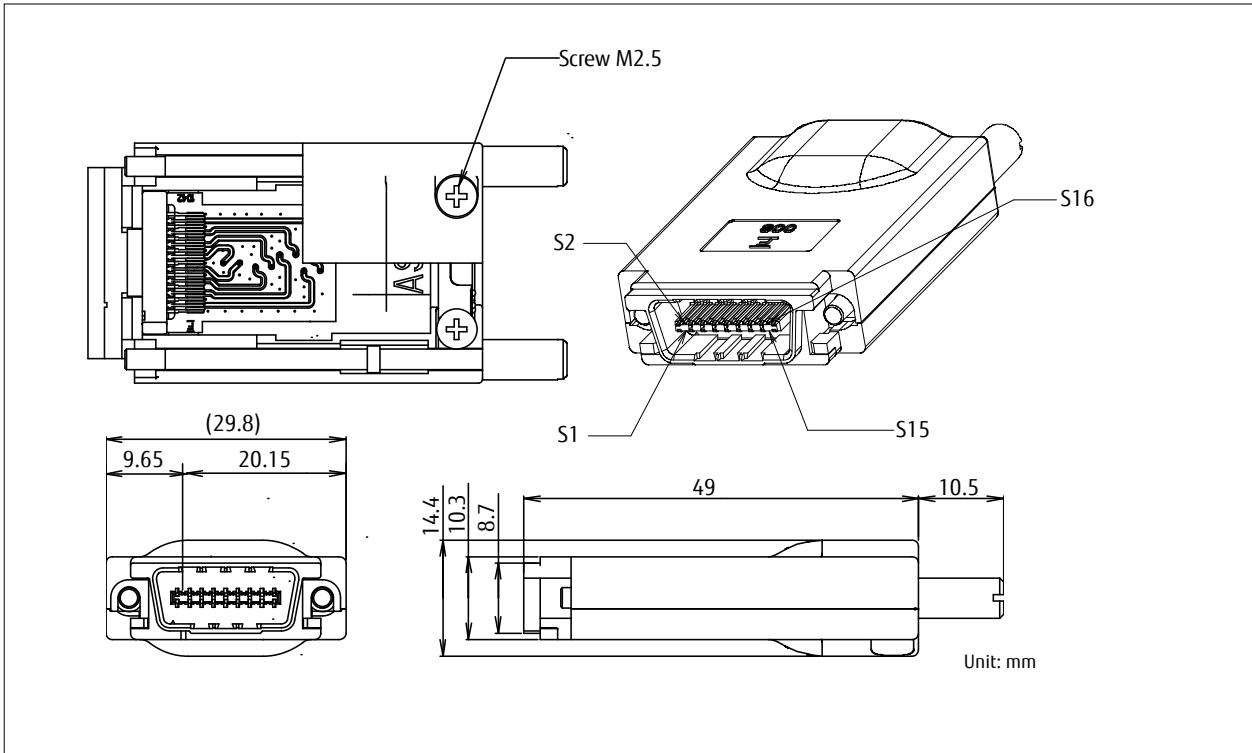

■ PART NUMBER

Part Number	Pair
FCN-261Z008-SL	8

Pin Number	
From	To
S1	S16
S2	S15
S3	S14
S4	S13
S5	S12
S6	S11
S7	S10
S8	S9

microGiGaCN™ FCN-260 (D) Series

4X / 12X BACKSHELL KIT, THUMBSCREWS

■ DIMENSIONS

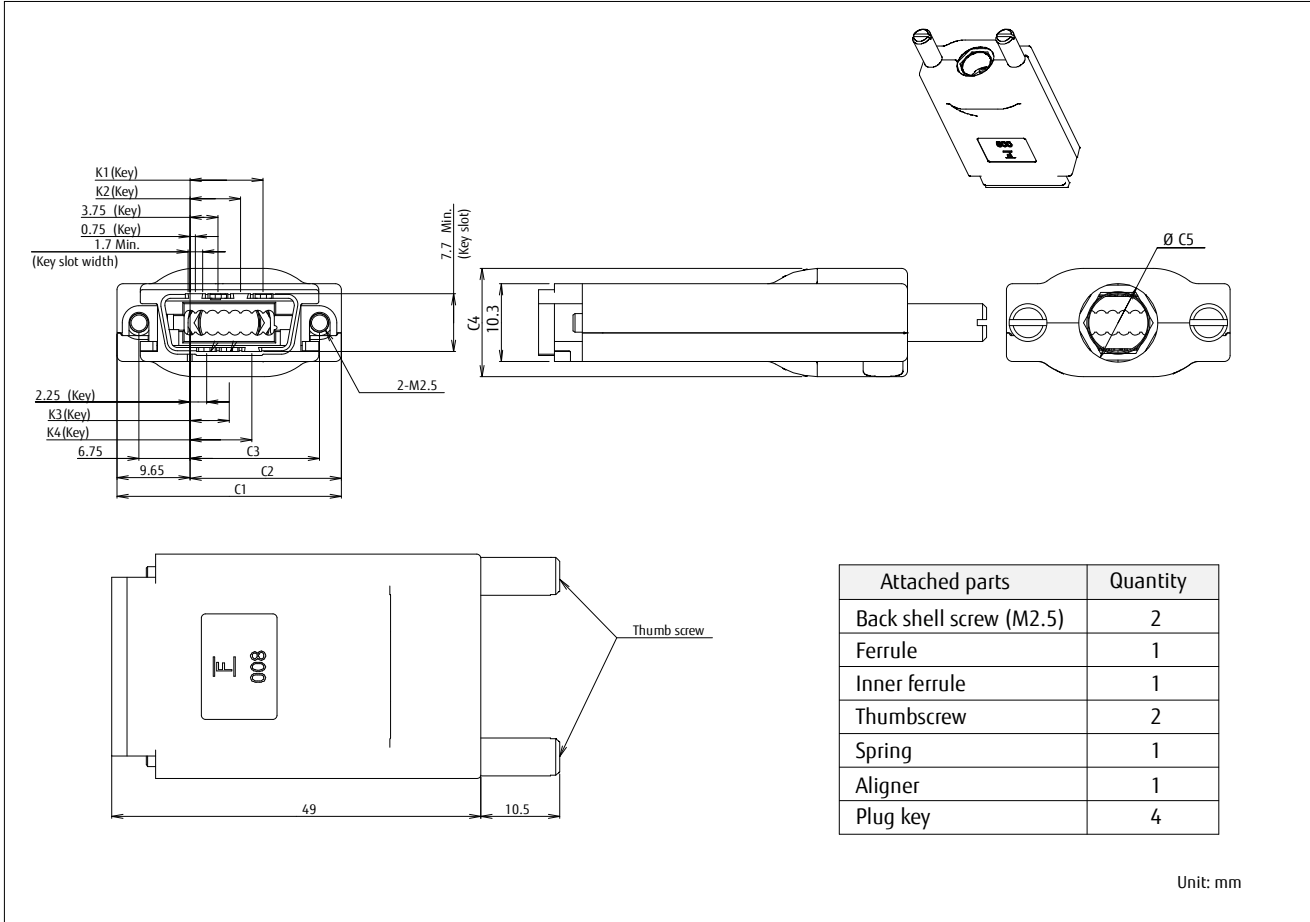

■ PART NUMBERS

Part Number	Pair	Cable	Dimensions (mm)								
			C1	C2	C3	C4	C5	K1	K2	K3	K4
FCN-260C008-A/S3	8	24AWG	29.8	20.15	17.25	14.4	10.45	9.75	6.75	5.25	8.25
FCN-260C008-C/S3		26AWG	29.8	20.15	17.25	14.4	9.23	9.75	6.75	5.25	8.25
FCN-260C024-A/S3	24	24AWG	53.8	44.15	41.25	21.0	15.65	33.75	30.75	29.25	32.25
FCN-260C024-C/S3		26AWG	53.8	44.15	41.25	17.5	14.3	33.75	30.75	29.25	32.25

microGiGaCN™ FCN-260 (D) Series

■ ASSEMBLY TOOLS

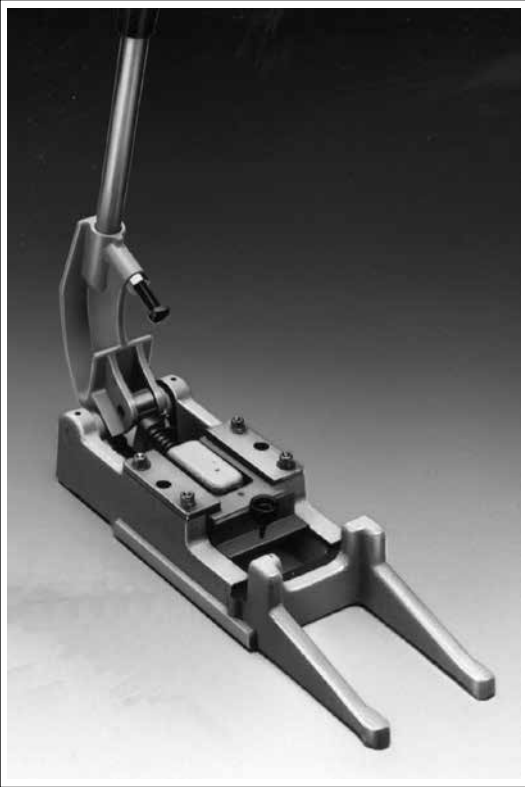

FCN-237T-T109/H
Hand Press

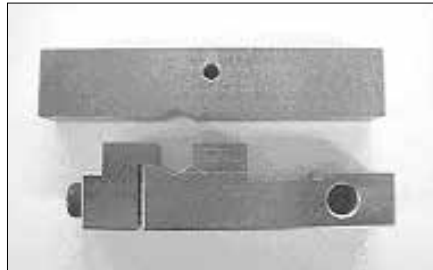

Ferrule Crimp Dies

Ferrule Crimp Dies

Part Number	Applicable Backshell	Applicable Cable OD	Notes
FCN-261T-T002/H	FCN-260C008-A/L0	9.53±0.4	Normally 8 pair, 24AWG
	FCN-260C008-A/S3	0.375±0.015	
FCN-261T-T103/H	FCN-260C008-C/L0	8.38±0.4	Normally 8 pair, 26AWG or 28AWG
	FCN-260C008-C/S3	0.330±0.015	
FCN-261T-T101/H	FCN260C024-E/L0	11.05±0.4	Normally 24 pair, 28AWG
		0.435±0.015	
FCN-261T-T105/H	FCN-260C024-A/L0	15.49±0.4	Normally 24 pair, 24AWG
	FCN-260C024-A/S3	0.610±0.015	

Both the press and ferrule crimp tool are required for the ferrule crimp process.
Note that additional tooling will be added to cover smaller wire bundle O.D.s. Please check with factory.

microGiGaCN™ FCN-260 (D) Series

■ INSTRUCTIONS FOR CABLE ASSEMBLY

1. Set the crimping dies onto the hand press

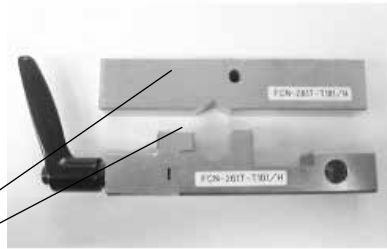
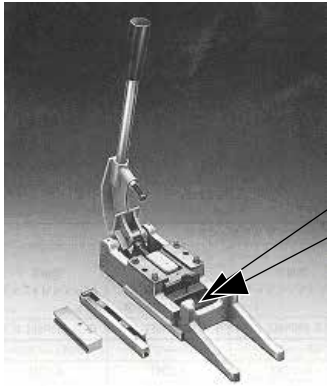

After a set is completed

2. A ferrule and a spring are put on the cable.

a. Strip the cable insulator and put the spring, which shall be moved at the position where it does not interfere with assembly process.

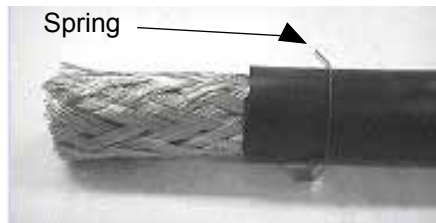

b. The shield braid is turned back and cut the length of 13mm (0.512 in.)

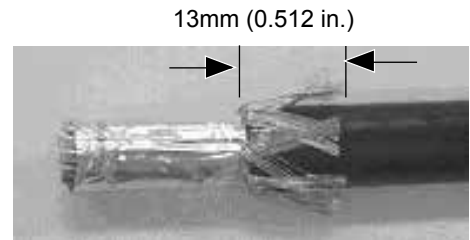

c. A ferrule is put on the position of 2mm from the end of the jacket

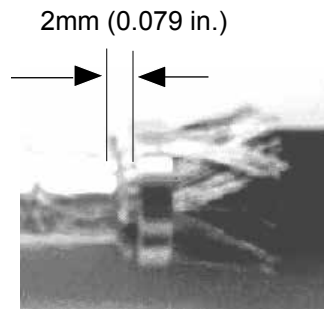

d. Strip the shield pair of wires (27mm [1.063in.] from the ring edge) and then wire insulation (27.5mm [1.082 in.]).



e. A shield of pair wires passed through the aligner, and solder the wires onto the paddle card.

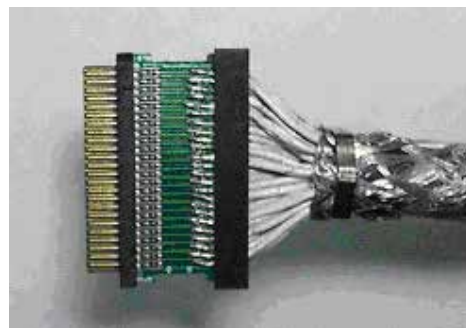

microGiGaCN™ FCN-260 (D) Series

3. Ferrule crimping:

To explain the process clearly, the following photos do not have a paddle card.

a. Set the cable onto right side of the jig, and end of the jig, ferrule edges are made to become parallel, and surface of provisional crimp and the connector made to parallel, pre-crimp the ferrule until part A, D hit parts B, E. (The ferrule becomes an eclipse).

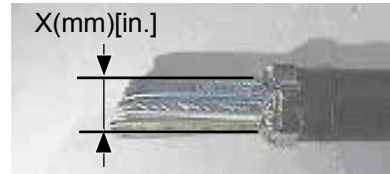
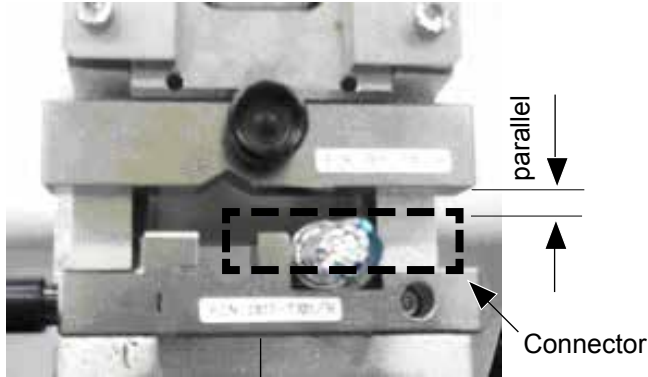

Cable		X (mm) [in.]
Pair	AWG	
8	24	10.5 [0.413]
24	24	15.60 [0.614]

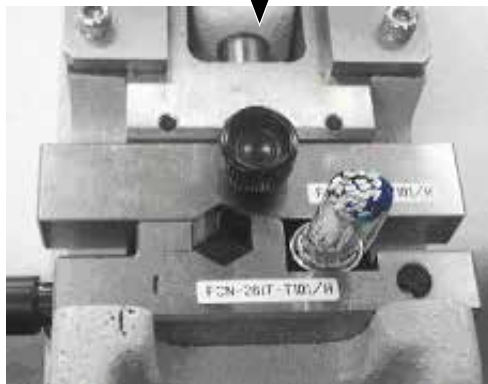

b. Confirm that lever is tightened hardly. If it isn't, a lever shall be pulled to the front and tightened.

c. Set the cable at the table cavity at the left side. (The ferrule edge/end face shall be parallel to the jig).

If a ring is not able to be inserted into the hollow, loosen with the lever, and insert the ferrule again. Then tighten with the lever.



d. Crimp ferrule until parts A, D hit parts B, E.

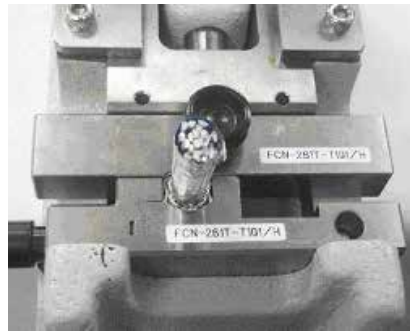

e. Hand press is returned to the original position, and loosened with the lever pulling forward.

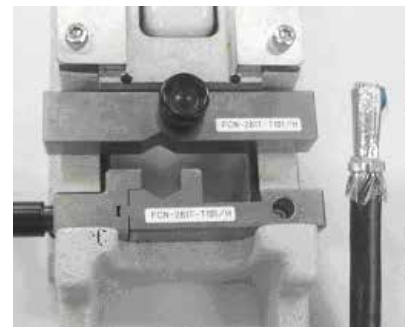

f. Crimp completion.

microGiGaCN™ FCN-260 (D) Series

Check Y dimension:

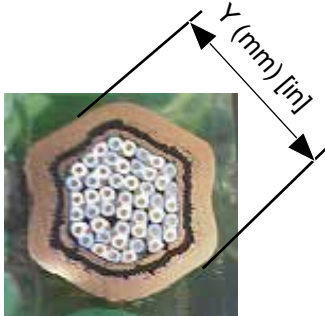

Cable		Y (mm) [in.]
Pair	AWG	
8	24	10.8 [0.425]
24	24	16.00 [0.630]

4. Turn back the jacket and cut in the ferrule edge.

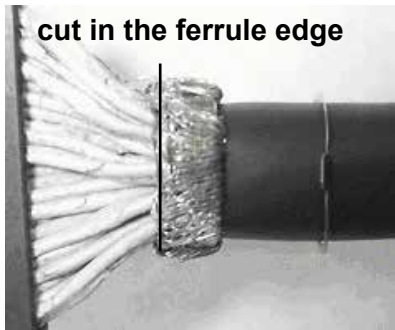
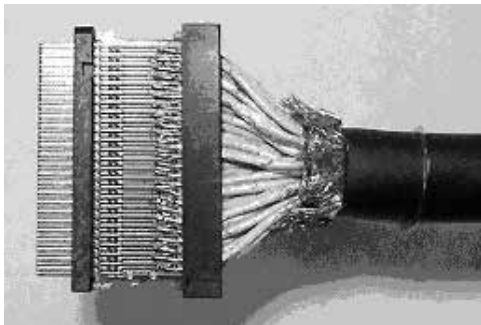

5. Installation of cover:

g. Set the cable and soldered with the paddle card into the outer cover. (#1 pin position side of the connector shall be on top) and put another cover, and set the spring, which is initially put on the cable, at the edge of the ferrule and install it inside and then fix the covers with the screws.

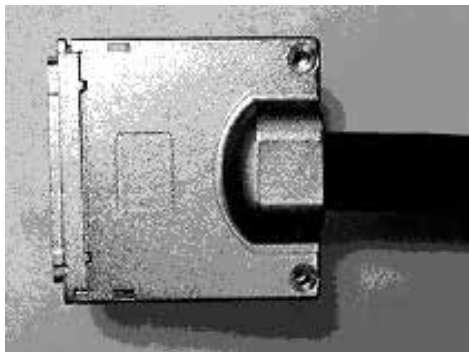
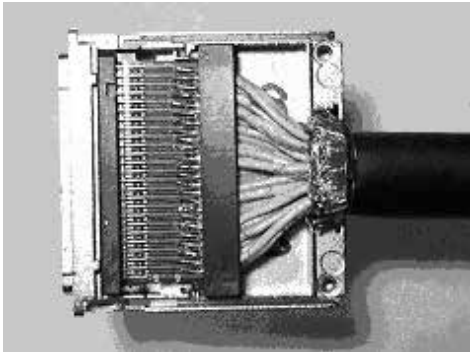

microGiGaCN™ FCN- 260 (D) Series

Fujitsu Components International Headquarter Offices

Contact

Japan

FUJITSU COMPONENT LIMITED
Shinagawa Seaside Park Tower
12-4, Higashi-shinagawa 4-chome,
Tokyo 140 0002, Japan
Tel: (81-3) 3450-1681
Fax: (81-3) 3474-2385
Email: fcl-contact@cs.jp.fujitsu.com
Web: www.fujitsu.com/jp/group/fcl/en/

Europe

FUJITSU COMPONENTS EUROPE B.V.
Diamantlaan 25
2132 WV Hoofddorp
Netherlands
Tel: (31-23) 5560910
Fax: (31-23) 5560950
Email: info@fceu.fujitsu.com
Web: emea.fujitsu.com/components/

China

FUJITSU ELECTRONIC COMPONENTS
(SHANGHAI) CO., LTD.
Unit 4306, InterContinental Center
100 Yu Tong Road, Shanghai 200070,
China
Tel: (86 21) 3253 0998 /Fax: (86 21) 3253 0997
Email: fcal@fcal.fujitsu.com
www.fujitsu.com/sg/products/devices/components/

North and South America

FUJITSU COMPONENTS AMERICA, INC.
2290 North First Street, Suite 212
San Jose, CA 95131 U.S.A.
Tel: (1-408) 745-4900
Fax: (1-408) 745-4970
Email: components@us.fujitsu.com
Web: http://us.fujitsu.com/components/

Asia Pacific

FUJITSU COMPONENTS ASIA, LTD.
102E Pasir Panjang Road
#01-01 Citilink Warehouse Complex,
Singapore 118529
Tel: (65) 6375-8560 / Fax: (65) 6273-3021
Email: fcal@fcal.fujitsu.com
www.fujitsu.com/sg/products/devices/components/

Hong Kong

FUJITSU COMPONENTS HONG KONG CO., LTD.
Room 06, 28/F, Greenfield Tower, Concordia Plaza,
No.1 Science Museum Road,
Tsim Sha Tsui East, Kowloon, Hong Kong
Tel: (852) 2881 8495 Fax: (852) 2894 9512
Email: fcal@fcal.fujitsu.com
www.fujitsu.com/sg/products/devices/components/

Korea

FUJITSU COMPONENTS KOREA, LTD.
Alpha Tower #403,
645 Sampyeong-dong,
Bundang-gu, Seongnam-si,
Gyeonggi-do, 13524 Korea
Tel: (82 31) 708-7108
Fax: (82 31) 709-7108
Email: fcal@fcal.fujitsu.com
www.fujitsu.com/sg/products/devices/components/

Copyright

All trademarks or registered trademarks are the property of their respective owners. Fujitsu Components America or its affiliates do not warrant that the content of datasheet is error free. In a continuing effort to improve our products Fujitsu Components America, Inc. or its affiliates reserve the right to change specifications/datasheets without prior notice.

Copyright ©2016 Fujitsu Components America, Inc. All rights reserved. Revised December 9, 2016
