

**SANYO****FH201****VCO OSC Circuit Applications****Features**

- Composite type with a buffer transistor (2SC4871) and a oscillator transistor (2SC4867) contained in the currently provided MCP package as a VCO oscillator, improving the mounting efficiency greatly.
- The FH201 is formed with two chips, being equivalent to the 2SC4871 and 2SC4867, placed in one package.
- Optimal for use in UHF band oscillator circuit.

**Package Dimensions**

unit:mm

2149

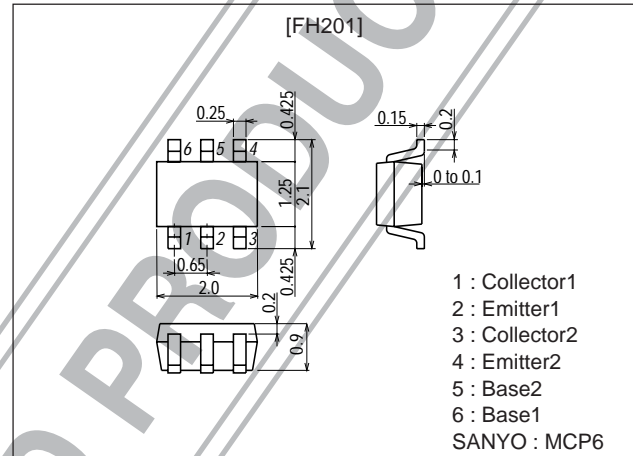
**Specifications****Absolute Maximum Ratings** at Ta = 25°C

Parameter	Symbol	Conditions	Ratings	Unit
Tr1 [2SC4871]				
Collector-to-Base Voltage	V <sub>CB0</sub>		16	V
Collector-to-Emitter Voltage	V <sub>CE0</sub>		8	V
Emitter-to-Base Voltage	V <sub>EB0</sub>		1.5	V
Collector Current	I <sub>C</sub>		20	mA
Collector Dissipation	P <sub>C</sub>		150	mW
Tr2 [2SC4867]				
Collector-to-Base Voltage	V <sub>CB0</sub>		16	V
Collector-to-Emitter Voltage	V <sub>CE0</sub>		8	V
Emitter-to-Base Voltage	V <sub>EB0</sub>		1.5	V
Collector Current	I <sub>C</sub>		50	mA
Collector Dissipation	P <sub>C</sub>		150	mW
[Common specifications]				
Total Dissipation	P <sub>T</sub>		200	mW
Junction Temperature	T <sub>J</sub>		150	°C
Storage Temperature	T <sub>stg</sub>		-55 to +150	°C

■ Any and all SANYO products described or contained herein do not have specifications that can handle applications that require extremely high levels of reliability, such as life-support systems, aircraft's control systems, or other applications whose failure can be reasonably expected to result in serious physical and/or material damage. Consult with your SANYO representative nearest you before using any SANYO products described or contained herein in such applications.

■ SANYO assumes no responsibility for equipment failures that result from using products at values that exceed, even momentarily, rated values (such as maximum ratings, operating condition ranges, or other parameters) listed in products specifications of any and all SANYO products described or contained herein.

**SANYO Electric Co.,Ltd. Semiconductor Company**

TOKYO OFFICE Tokyo Bldg., 1-10, 1 Chome, Ueno, Taito-ku, TOKYO, 110-8534 JAPAN

Electrical Characteristics at Ta = 25°C

Parameter	Symbol	Conditions	Ratings			Unit
			min	typ	max	
Tr1 [2SC4871]						
Collector Cutoff Current	$I_{CBO}$	$V_{CB}=10V, I_E=0$			1.0	$\mu A$
Emitter Cutoff Current	$I_{EBO}$	$V_{EB}=1V, I_C=0$			10	$\mu A$
DC Current Gain	$h_{FE}$	$V_{CE}=5V, I_C=4mA$	90		180	
Gain-Bandwidth Product	$f_T$	$V_{CE}=5V, I_C=4mA$		10		GHz
Output Capacitance	$C_{ob}$	$V_{CB}=10V, f=1MHz$		0.4	0.7	pF
Forward Transfer Gain	$ S_{21e} ^2$	$V_{CE}=5V, I_C=7mA, f=1GHz$	10	13		dB
Noise Figure	NF	$V_{CE}=5V, I_C=4mA, f=1GHz$		1.3	2.8	dB
Tr2 [2SC4867]						
Collector Cutoff Current	$I_{CBO}$	$V_{CB}=10V, I_E=0$			1.0	$\mu A$
Emitter Cutoff Current	$I_{EBO}$	$V_{EB}=1V, I_C=0$			10	$\mu A$
DC Current Gain	$h_{FE}$	$V_{CE}=5V, I_C=15mA$	90		180	
Gain-Bandwidth Product	$f_T$	$V_{CE}=5V, I_C=15mA$		9.0		GHz
Output Capacitance	$C_{ob}$	$V_{CB}=10V, f=1MHz$		0.6	1.1	pF
Forward Transfer Gain	$ S_{21e} ^2$	$V_{CE}=5V, I_C=15mA, f=1GHz$	10	13		dB
Noise Figure	NF	$V_{CE}=5V, I_C=5mA, f=1GHz$		1.2	2.5	dB

Marking : 201

Electrical Connection

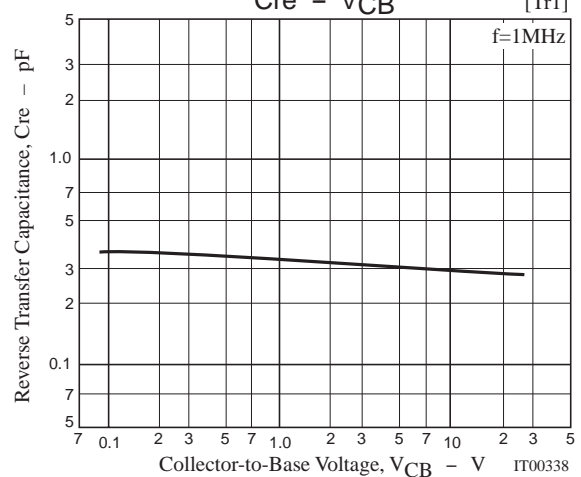
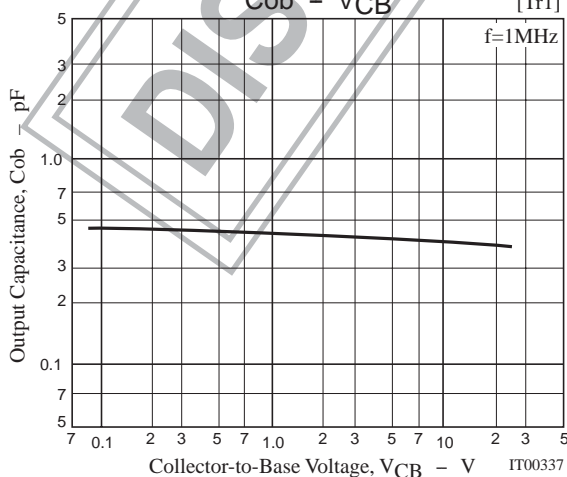
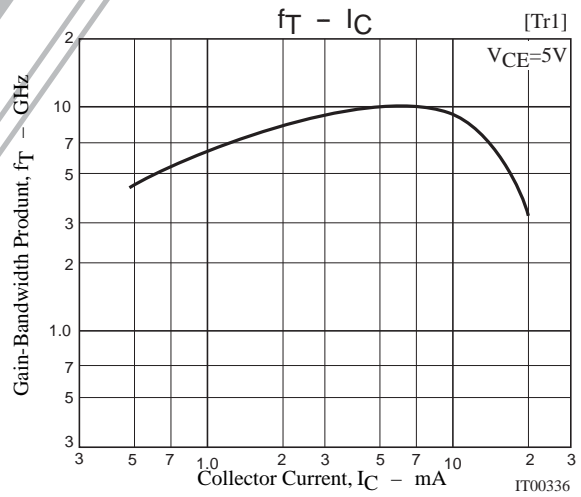
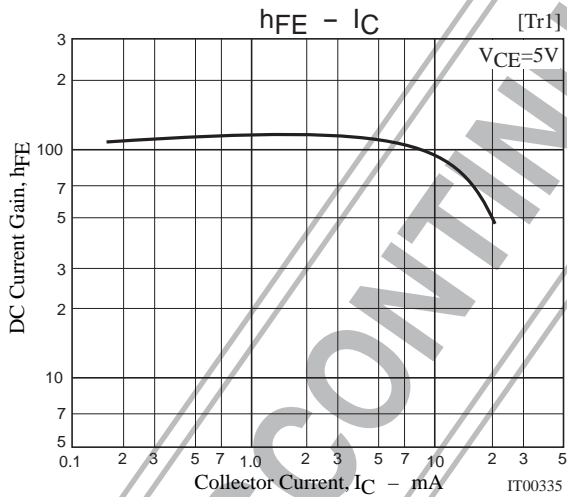
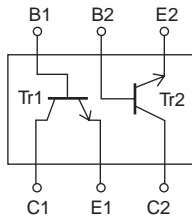

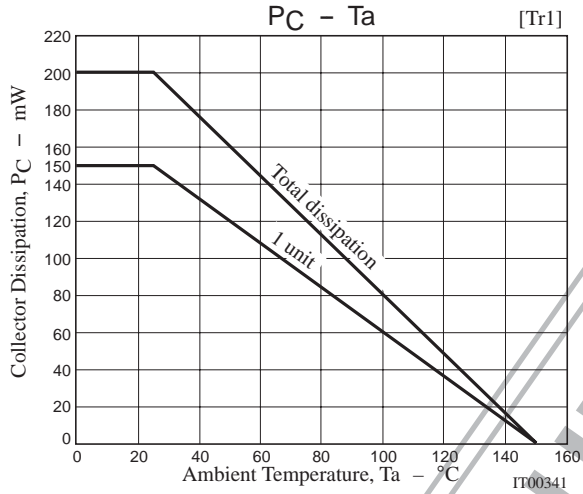
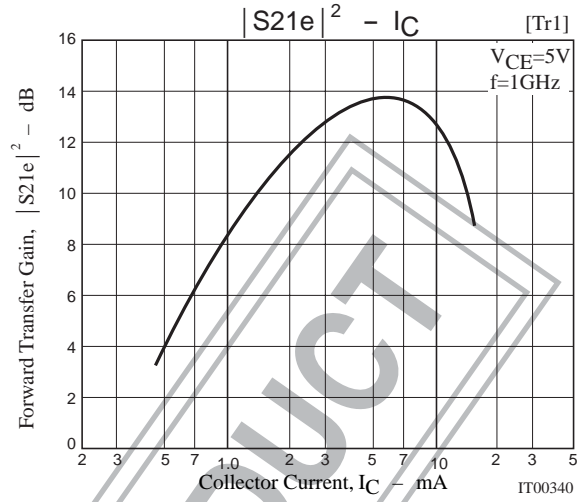
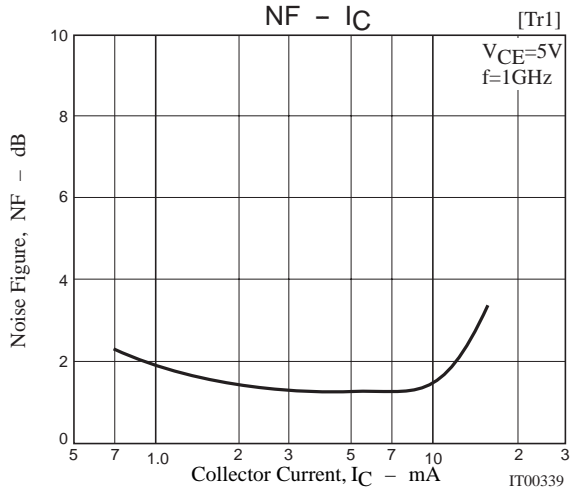

DISCONTINUED PRODUCT

**S parameter [Tr1]**

$V_{CE}=5V$   
 $f=200MHz$  to  $2000MHz(200MHz$  Step)  
 $S_{11e}$

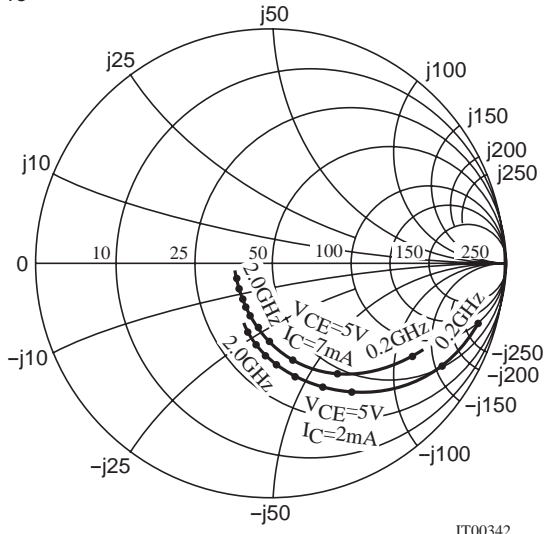

$V_{CE}=5V$   
 $f=200MHz$  to  $2000MHz(200MHz$  Step)  
 $S_{21e}$

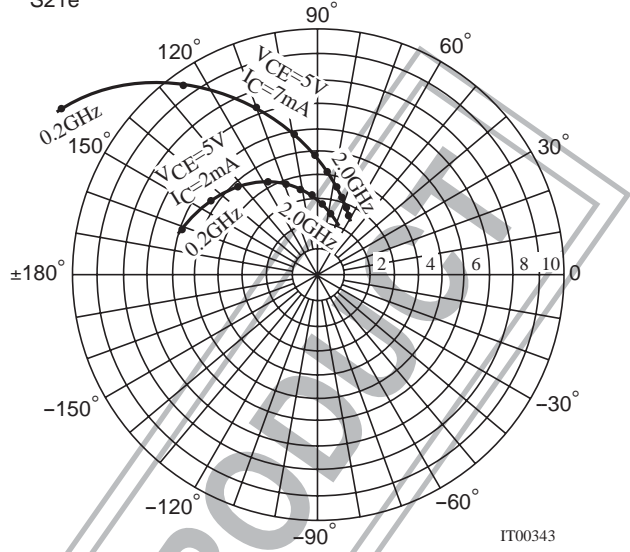

$V_{CE}=5V$   
 $f=200MHz$  to  $2000MHz(200MHz$  Step)  
 $S_{12e}$

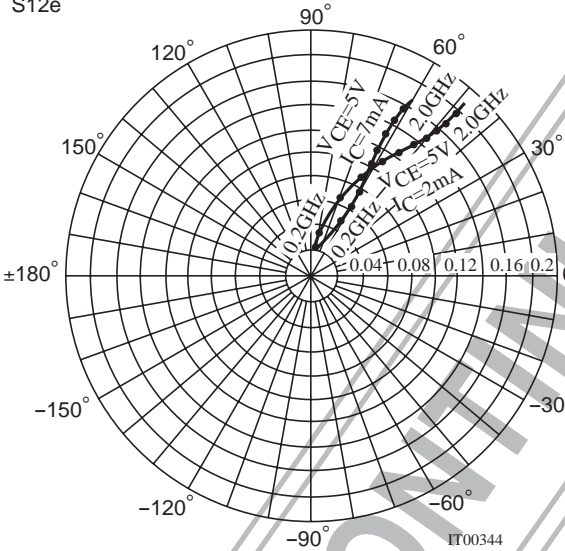

$V_{CE}=5V$   
 $f=200MHz$  to  $2000MHz(200MHz$  Step)  
 $S_{22e}$

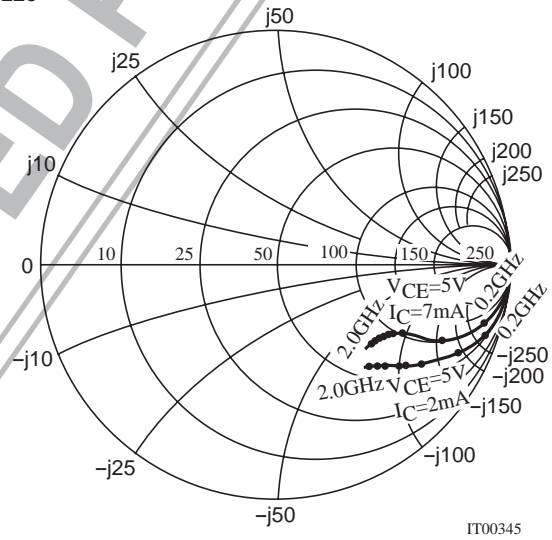

DISCONTINUED PRODUCT

**S Parameters (Common emitter) [Tr1]** $V_{CE}=5V, I_C=2mA, Z_O=50\Omega$ 

Freq (MHz)	$ S_{11} $	$\angle S_{11}$	$ S_{21} $	$\angle S_{21}$	$ S_{12} $	$\angle S_{12}$	$ S_{22} $	$\angle S_{22}$
200	0.912	-17.6	5.764	161.5	0.034	79.0	0.974	-40.3
400	0.835	-33.0	5.282	145.5	0.065	69.9	0.919	-49.2
600	0.742	-46.9	4.753	131.2	0.088	62.8	0.850	-26.3
800	0.649	-58.9	4.268	119.4	0.107	57.9	0.789	-31.6
1000	0.578	-68.7	3.840	109.4	0.121	54.5	0.740	-35.5
1200	0.512	-78.1	3.440	100.5	0.134	52.2	0.698	-38.9
1400	0.445	-86.3	3.123	92.5	0.145	50.3	0.664	-41.6
1600	0.400	-93.0	2.836	85.2	0.154	49.2	0.638	-44.3
1800	0.359	-98.5	2.588	79.0	0.164	48.4	0.615	-46.3
2000	0.319	-106.6	2.297	73.0	0.174	47.9	0.601	-48.3

 $V_{CE}=5V, I_C=7mA, Z_O=50\Omega$ 

Freq (MHz)	$ S_{11} $	$\angle S_{11}$	$ S_{21} $	$\angle S_{21}$	$ S_{12} $	$\angle S_{12}$	$ S_{22} $	$\angle S_{22}$
200	0.721	-35.1	12.262	147.1	0.030	72.8	0.900	-46.9
400	0.555	-59.9	9.445	124.9	0.050	64.4	0.763	-25.6
600	0.428	-77.5	7.290	110.2	0.065	61.9	0.666	-29.3
800	0.344	-89.9	5.877	100.1	0.078	61.5	0.611	-31.1
1000	0.291	-100.6	4.911	92.1	0.091	61.7	0.583	-32.5
1200	0.254	-110.9	4.223	85.1	0.104	61.5	0.563	-34.1
1400	0.221	-121.4	3.703	79.0	0.117	61.6	0.551	-35.7
1600	0.197	-128.9	3.294	73.6	0.129	61.6	0.540	-37.8
1800	0.178	-136.7	2.946	68.5	0.143	61.1	0.530	-39.7
2000	0.171	-148.6	2.692	63.8	0.157	60.7	0.529	-41.7

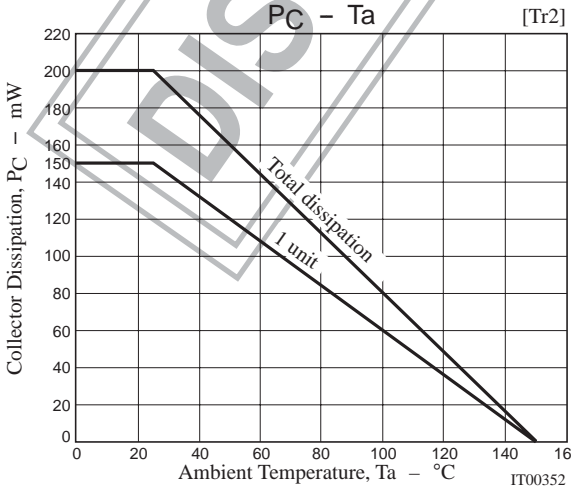
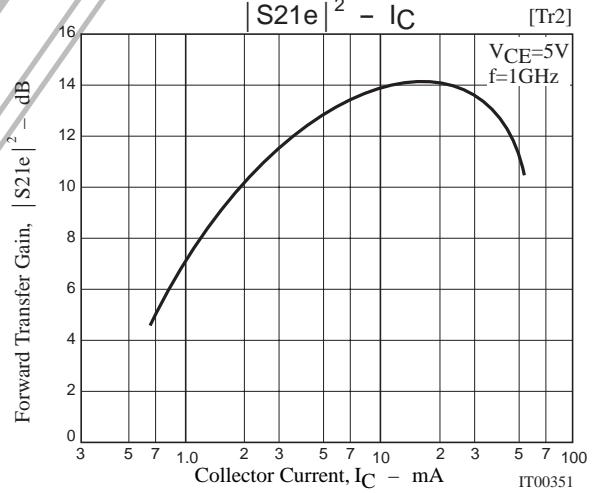
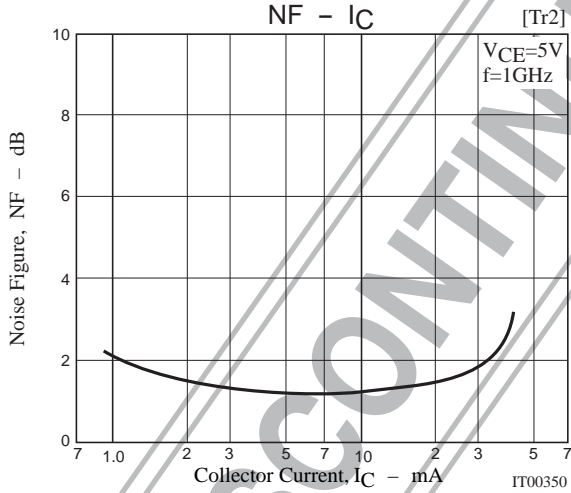
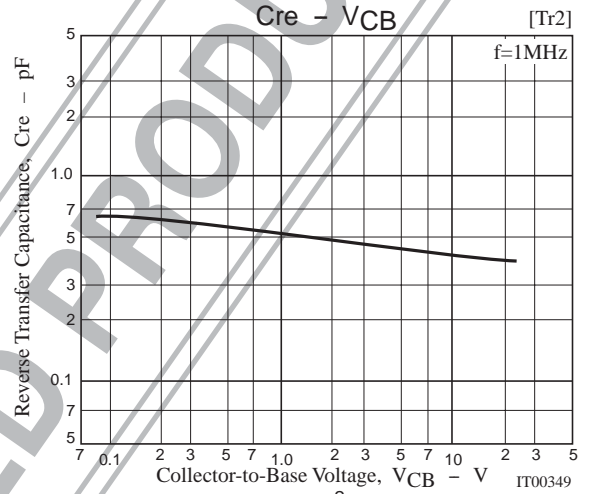
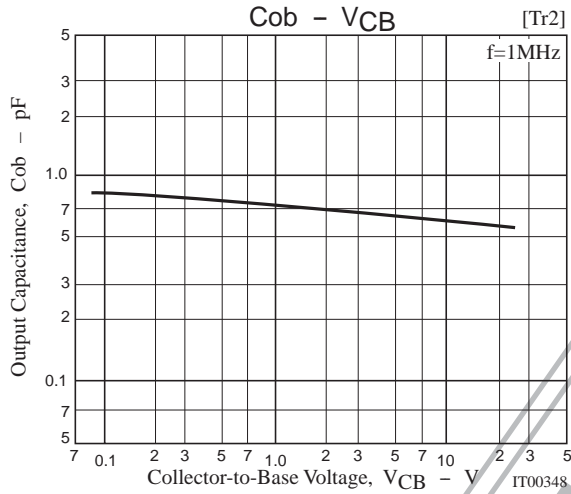
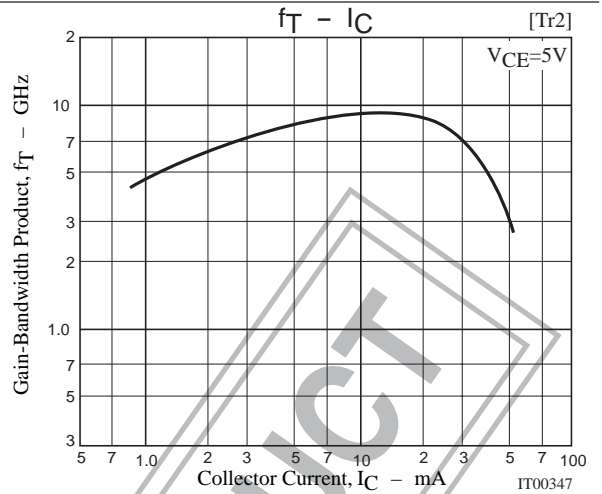
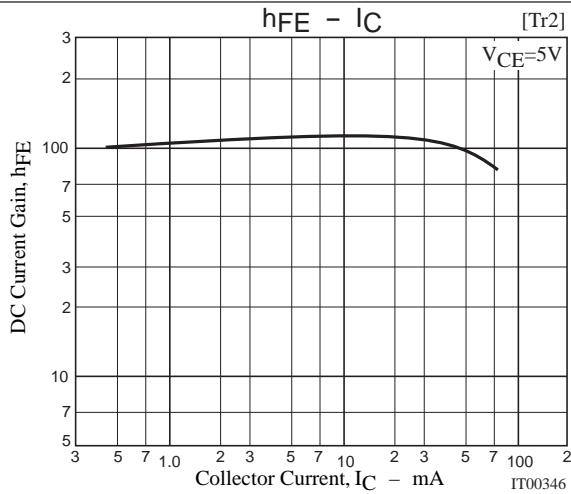

**S parameter [Tr2]**

$V_{CE}=5V$   
 $f=200MHz$  to  $2000MHz(200MHz$  Step)  
 $S_{11e}$

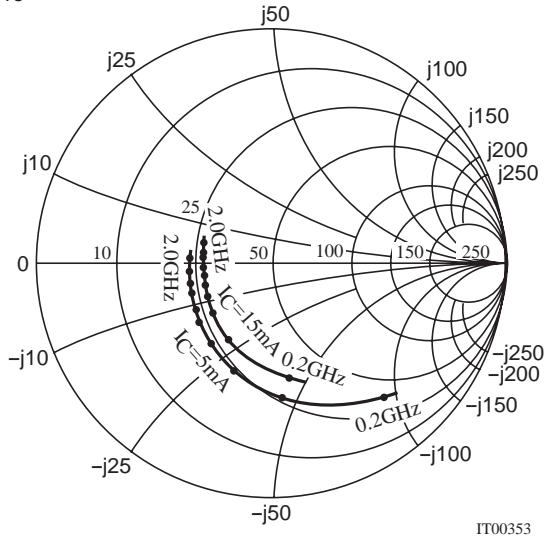

$V_{CE}=5V$   
 $f=200MHz$  to  $2000MHz(200MHz$  Step)  
 $S_{21e}$

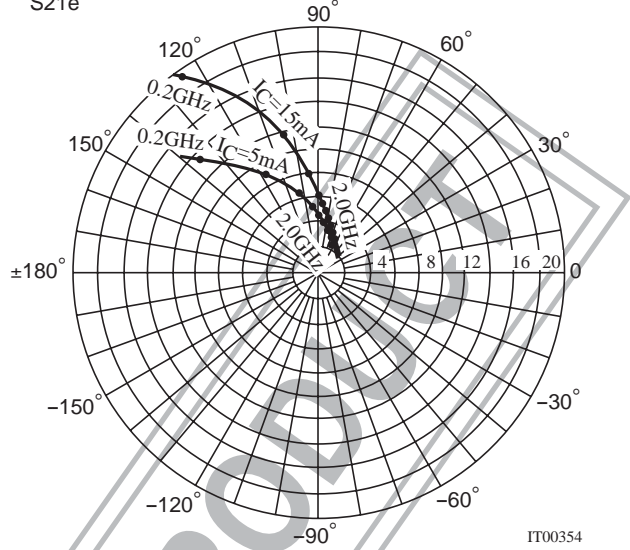

$V_{CE}=5V$   
 $f=200MHz$  to  $2000MHz(200MHz$  Step)  
 $S_{12e}$

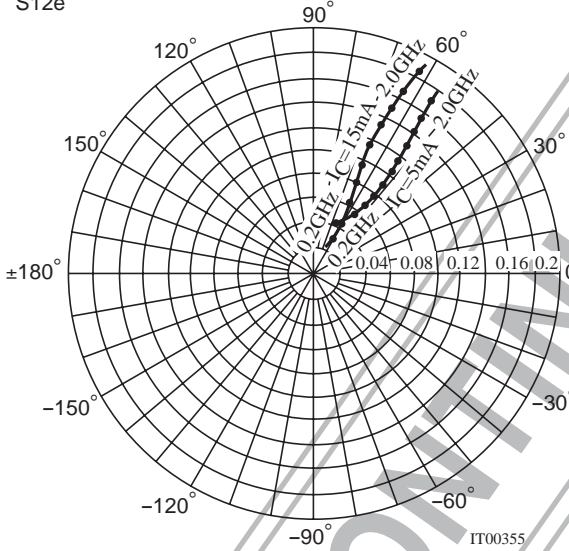

$V_{CE}=5V$   
 $f=200MHz$  to  $2000MHz(200MHz$  Step)  
 $S_{22e}$

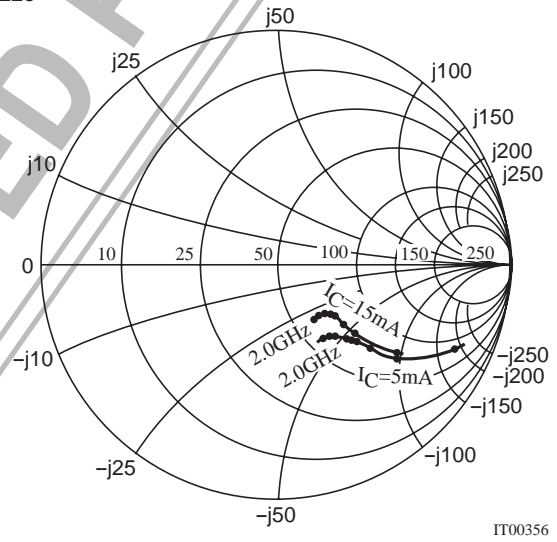

DISCONTINUED PRODUCT

**S Parameters (Common emitter) [Tr2]** $V_{CE}=5V, I_C=5mA, Z_O=50\Omega$ 

Freq (MHz)	$ S_{11} $	$\angle S_{11}$	$ S_{21} $	$\angle S_{21}$	$ S_{12} $	$\angle S_{12}$	$ S_{22} $	$\angle S_{22}$
200	0.749	-50.7	12.229	141.6	0.044	65.4	0.847	-25.4
400	0.583	-85.7	8.900	118.1	0.068	54.3	0.655	-37.4
600	0.487	-109.6	6.636	103.7	0.081	51.6	0.538	-42.3
800	0.428	-126.6	5.276	93.9	0.093	51.6	0.473	-44.4
1000	0.405	-139.3	4.379	85.9	0.106	52.6	0.443	-46.2
1200	0.387	-150.6	3.731	78.7	0.117	53.6	0.421	-48.1
1400	0.377	-160.1	3.258	72.6	0.130	54.4	0.405	-49.6
1600	0.365	-166.8	2.924	67.5	0.142	55.2	0.393	-52.1
1800	0.362	-174.3	2.589	61.9	0.156	55.6	0.387	-54.3
2000	0.361	178.3	2.363	56.8	0.171	55.9	0.383	-56.4

 $V_{CE}=5V, I_C=7mA, Z_O=50\Omega$ 

Freq (MHz)	$ S_{11} $	$\angle S_{11}$	$ S_{21} $	$\angle S_{21}$	$ S_{12} $	$\angle S_{12}$	$ S_{22} $	$\angle S_{22}$
200	0.507	-81.6	19.422	124.2	0.033	61.9	0.650	-36.9
400	0.382	-119.5	11.595	103.8	0.050	61.0	0.445	-43.0
600	0.341	-140.9	8.046	93.3	0.065	63.3	0.365	-43.5
800	0.332	-154.0	6.182	86.4	0.081	65.1	0.330	-43.3
1000	0.320	-163.0	5.063	79.8	0.099	65.6	0.318	-43.8
1200	0.316	-170.9	4.263	74.1	0.116	65.7	0.311	-45.9
1400	0.315	-178.0	3.716	69.2	0.134	65.0	0.304	-47.4
1600	0.314	176.7	3.270	64.3	0.150	64.4	0.297	-50.3
1800	0.311	171.2	2.922	60.0	0.167	63.3	0.293	-52.6
2000	0.313	165.4	2.656	55.9	0.186	62.1	0.295	-54.8

- Specifications of any and all SANYO products described or contained herein stipulate the performance, characteristics, and functions of the described products in the independent state, and are not guarantees of the performance, characteristics, and functions of the described products as mounted in the customer's products or equipment. To verify symptoms and states that cannot be evaluated in an independent device, the customer should always evaluate and test devices mounted in the customer's products or equipment.
- SANYO Electric Co., Ltd. strives to supply high-quality high-reliability products. However, any and all semiconductor products fail with some probability. It is possible that these probabilistic failures could give rise to accidents or events that could endanger human lives, that could give rise to smoke or fire, or that could cause damage to other property. When designing equipment, adopt safety measures so that these kinds of accidents or events cannot occur. Such measures include but are not limited to protective circuits and error prevention circuits for safe design, redundant design, and structural design.
- In the event that any or all SANYO products (including technical data, services) described or contained herein are controlled under any of applicable local export control laws and regulations, such products must not be exported without obtaining the export license from the authorities concerned in accordance with the above law.
- No part of this publication may be reproduced or transmitted in any form or by any means, electronic or mechanical, including photocopying and recording, or any information storage or retrieval system, or otherwise, without the prior written permission of SANYO Electric Co., Ltd.
- Any and all information described or contained herein are subject to change without notice due to product/technology improvement, etc. When designing equipment, refer to the "Delivery Specification" for the SANYO product that you intend to use.
- Information (including circuit diagrams and circuit parameters) herein is for example only; it is not guaranteed for volume production. SANYO believes information herein is accurate and reliable, but no guarantees are made or implied regarding its use or any infringements of intellectual property rights or other rights of third parties.

This catalog provides information as of November, 1999. Specifications and information herein are subject to change without notice.