

REVISIONS			
LTR	DESCRIPTION	DATE	APPROVED
NC	INITIAL RELEASE PER ECN T-17315	92JUL7	ZET
A	REVISED PER ECN T-18756	93 Nov 23	346

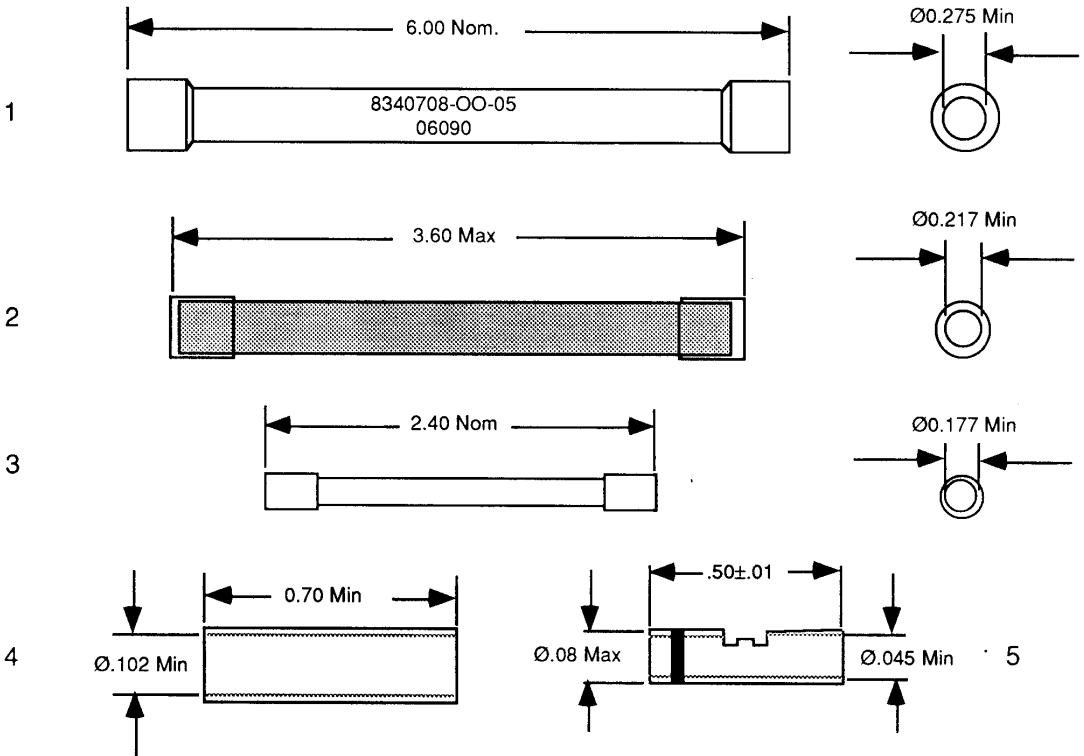

- 1 Outer heat - shrinkable tubing with two sealing inserts, black.
- 2 Flexible shield joint with two pre - installed terminators.
- 3 Inner heat - shrinkable tubing with two sealing inserts, black.
- 4 Insulation sleeves (2), blue translucent.
- 5 Crimp ferrules (2), red stripe code.

Specification Control Drawing

If this document is printed it becomes uncontrolled.
Check for the latest revision.

UNLESS OTHERWISE SPECIFIED DIMENSIONS ARE IN INCHES. METRIC DIMENSIONS ARE IN BRACKETS.	DRAWN	346	92JUL7	Tyco Electronics Corporation 300 Constitutional Drive Menlo Park, CA 94025 USA 	TITLE FLEXIBLE SPLICE KIT		
	CHECKED	J.B.K.	93 NOV 23				
	APPROVED						
	APPROVED						
	CAD NAME						
DECIMALS .XXX ± [mm] .XX ± [mm] ANGLES .X ±	THIRD ANGLE PROJECTION			SIZE	CODE IDENT. NO.	DWG. NO.	REV
WEIGHT lbs [g]		A	06090	D-150-0708-5	A		
DO NOT SCALE THIS DRAWING				SCD	SHEET 1 OF 2		

1. MATERIALS

- 1.1 Outer heat-shrinkable tubing: high temperature fluid stabilized cross linked elastomer to Rachem specification RK-6008, sealing inserts: modified stabilized elastomer-fluoropolymer thermoplastic, black.
- 1.2 Flexible shield joint: double shield, tin plated copper ends, pre-tinned with Sn96 SRA solder. Pre-installed terminators : sleeves with Sn96 SRA solder preforms, per QQ-S-571.
- 1.3 Inner heat-shrinkable tubing, same as 1.1.
- 1.4 Insulation sleeves: modified irradiated polyvinylidene fluoride.
- 1.5 Crimp ferrules per MIL-S-81824/1-1.

2. APPLICATION

- 2.1 This flexible splice kit is designed to facilitate the assembly or maintenance of pre-cabled digital harness components for MIL-STD-1553B networks
- 2.2 To be used where continuous flexing is not a functional requirement.
- 2.3 Cables accommodated: 8421526-AO-01, 8421526-BO-01, 8421526-CO-01, 8421527-DO-01, and 8421528-EO-01.
- 2.4 Minimum bend radius, static 80mm. Dynamic: NOT RECOMMENDED..
- 2.5 Installation procedure, and tooling: Raychem RPIP-600-12.
- 2.6 For applications other than above, consult Raychem technical services.

3. TEMPERATURE RATING

- 3.1 Operating temperature: -65°C to +150°C, brief excursions to +200°C permissible without degradation.

4. PERFORMANCE SPECIFICATIONS

- 4.1 Designed to meet the performance requirements of U.S. Air Force 8340708

If this document is printed it becomes uncontrolled.
Check for the latest revision.

SIZE	CODE IDENT. NO.	DWG. NO.	REV
A	06090	D-150-0708-5	A
DO NOT SCALE THIS DRAWING		SCD	SHEET 2 OF 2