

AIR CYLINDER SERIES CG1
BORE SIZES Ø20~100MM

- ✓ Double acting
- ✓ Clean line
- ✓ A substantial reduction in overall length compared to tie bar designed cylinders
- ✓ High velocity
- ✓ Magnetic piston for auto switch sensing as an option
- ✓ Non-rotate option available



TECHNICAL SPECIFICATIONS

Fluid	Air
Proof pressure	15 Bar
Max operating pressure	9.9 Bar
Min operating pressure	0.5 Bar
Ambient and fluid temperature	-10~60°C
Piston velocity	50-700mm/sec (ø80-ø100)
Thread tolerance	JIS 2 class
Stroke length tolerance	ø20-63 up to ~1000st: ± 0.1 mm
Lubrication	None required

CONSTRUCTION SPECIFICATIONS

Rod cover	Aluminium alloy (Hard black alumite)
Body	Aluminium alloy (Hard alumite)
Piston rod	Carbon steel (hard chrome plated)

SYMBOLS
RUBBER CUSHIONED

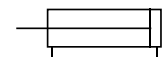

AIR CUSHIONED

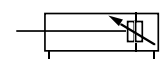

HOW TO ORDER

AIR CYLINDER SERIES CG1

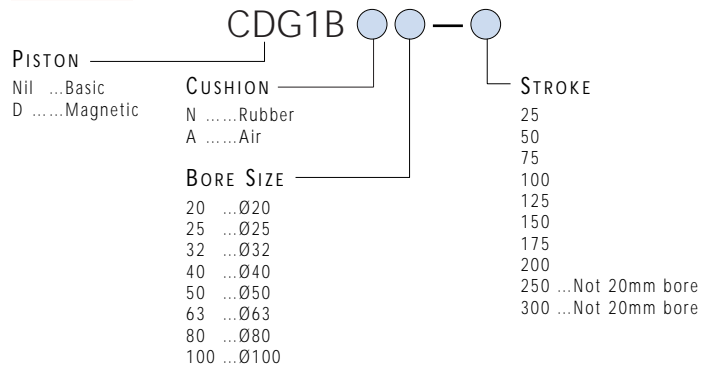

LONG STROKE - DOUBLE END - CAP CONSTRUCTION

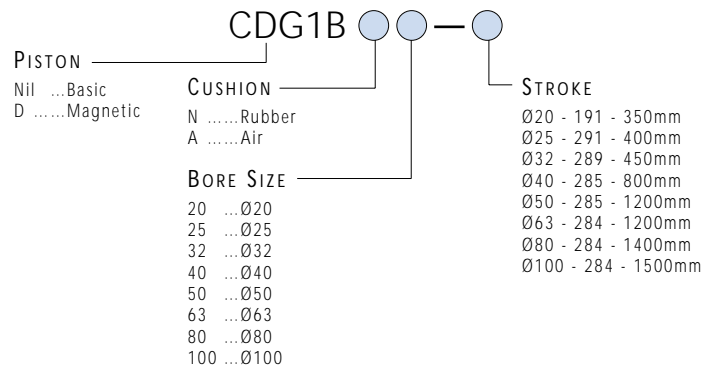

DOUBLE PISTON ROD

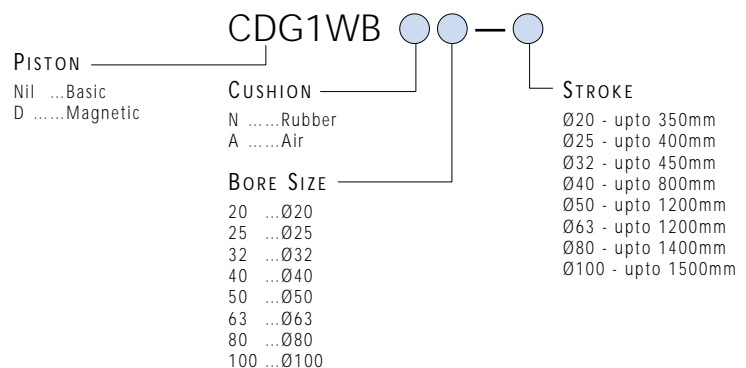

STOCKED PRODUCTS

FOR A LIST OF STOCKED PRODUCTS,
PLEASE SEE THE CURRENT SMC PRICE LIST

ACCESSORIES
AIR CYLINDER SERIES CG1

Bore size mm Mounting accessory	20	25	32	40	50	63	80	100
Foot (2 pcs)	CG-L020	CG-L025	CG-L032	CG-L040	CG-L050	CG-L063	CG-L080	CG-L100
Flange	CG-F020	CG-F025	CG-F032	CG-F040	CG-F050	CG-F063	CG-F080	CG-F100
Pins	CG-T020	CG-T025	CG-T032	CG-T040	CG-T050	CG-T063	N/A	N/A
Clevis	CG-D020	CG-D025	CG-D032	CG-D040	CG-D050	CG-D063	CG-D080	CG-D100
Single rod clevis	I-G02	I-G03	I-G03	I-G04	I-G05	I-G05	I-G08	I-G10
Double rod clevis	Y-G02	Y-G03	Y-G03	Y-G04	Y-G05	Y-G05	Y-G08	Y-G10
Rod clevis pin	IY-G02	IY-G03	IY-G03	IY-G04	IY-G05	IY-G05	IY-G08	IY-G10
Rear clevis pin	CD-G02	CD-G25	CD-G03	CD-G04	CD-G05	CD-G06	IY-G08	IY-G10
Trunnion bracket	CG-020-24A	CG-025-24A	CG-032-24A	CG-040-24A	CG-050-24A	CG-063-24A	CG-080-24A	CG-100-24A
Seal kit (Rubber cushion)	CG1N20-PS	CG1N25-PS	CG1N32-PS	CG1N40-PS	CG1N50-PS	CG1N63-PS	CG1N80-PS	CG1N100-PS
Seal kit (Air cushion)	CG1A20-PS	CG1A25-PS	CG1A32-PS	CG1A40-PS	CG1A50-PS	CG1A63-PS	CG1A80-PS	CG1A100-PS
Floating Joint	JA20-8-125	JA30-10-125	JA30-10-125	JA40-14-150	JA63-18-150	JA63-18-150	JA80-22-150	JA100-26-150
Piston Rod Ball Joint	KJ8D	KJ10D	KJ10D	-	-	-	-	-
Piston Rod Nut	NT-02	NT-03	NT-03	NT-04	NT-05	NT-05	NT-08	NT-10

ACCESSORIES
AUTO SWITCHES

	MODEL		TYPE	LOAD VOLTAGE	LOAD CURRENT	POWER SOURCE	INTERNAL VOLTAGE DROP	INDICATOR LAMP
	Part no	Part no						
	Grommet Type	Connector Type						
Ø20-63mm	D-B73L	D-B73CL	REED	24VDC 100VAC	5-40mA 5-20mA	-	MAX 2.4V	ON:Red LED
	D-B80L	D-B80CL	REED	24VDC/AC OR LESS 100VDC/AC	MAX 50mA MAX 20mA	-	0	NONE
	D-G79L		3 WIRE SOLID STATE NPN	28VDC OR LESS	MAX 150mA	5-28VDC	0.8V MAX	ON:Red LED
	D-k79L	D-k79CL	2 WIRE SOLID STATE	28VDC OR LESS	5-150mA	-	3V MAX	ON:Red LED
Ø20-100	D-B53L		REED	24VDC 100VAC	5-50mA 5-25mA	-	2.4V or less	ON:Red LED
	D-B54L		REED	24VDC 100VAC 200VAC/DC	5-50mA 5-25mA MAX 12.5mA	-	2.4V or less	ON:Red LED
	D-B64L		REED	24VDC/AC OR LESS 100VDC/AC 200VAC/DC	MAX 50mA MAX 25mA MAX 12.5mA	-	0	NONE
	D-G59L		3 WIRE SOLID STATE NPN	28VDC OR LESS	MAX 150mA	5-24VDC	0.8V or less	ON:Red LED
	D-G5PL		3 WIRE SOLID STATE PNP	28VDC OR LESS	MAX 100mA	5-24VDC	0.8V or less	ON:Red LED
	D-K59L		2 WIRE SOLID STATE	10-28VDC	5- 150mA	-	3V or less	ON:Red LED

ACCESSORIES
SWITCH BANDS
FOR SWITCHES D-B7, D-B8, D-G7

BM1-01Ø20
BM1-02Ø25
BM1-32Ø32
BM1-04Ø40
BM1-05Ø50
BM1-06Ø63

ACCESSORIES
SWITCH BANDS
FOR SWITCHES D-B5, D-B6

BA-01Ø20
BA-02Ø25
BA-32Ø32
BA-04Ø40
BA-05Ø50
BA-06Ø63
BA-08Ø80
BA-10Ø100

STOCKED PRODUCTS
FOR A LIST OF STOCKED PRODUCTS,
PLEASE SEE THE CURRENT SMC PRICE LIST



SEE INSIDE FRONT COVER FOR
DETAILS OF YOUR LOCAL SALES OFFICE



FOR FURTHER TECHNICAL
DETAILS ON THIS
PRODUCT REQUEST
CATALOGUE REFERENCE
E216

DIMENSIONS
RUBBER CUSHION TYPE CDG1BN

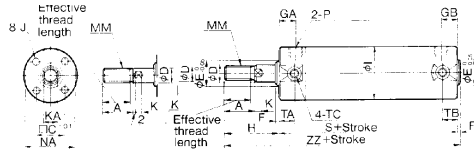

Bore (mm)	Stroke range (mm)	Effective thread length	A	□C	∅D	∅E	F	GA	GB	∅I	J	K	KA	MM	NA	P	S	TA	TB	*TC
20	-200	15.5	18	14	8	12	2	12	12	26	M4x0.7 Depth 7	4	6	M8x1.25	24	1/8	69	11	11	M5x0.8
25	-300	19.5	22	16.5	10	14	2	12	12	31	M5x0.8 Depth 7.5	5	8	M10x1.25	29	1/8	69	11	11	M6x0.75
32	-300	19.5	22	20	12	18	2	12	11	38	M5x0.8 Depth 8	5.5	10	M10x1.25	36	1/8	71	11	10	M8x1.0
40	-300	27	30	26	16	25	2	13	12	47	M6x1 Depth 12	6	14	M14x1.5	44	1/8	78	12	10	M10x1.25
50	-300	32	35	32	20	30	2	14	13	58	M8x1.25 Depth 16	7	18	M18x1.5	55	1/8	90	13	12	M12x1.25
63	-300	32	35	38	20	32	2	14	13	72	M10x1.5 Depth 16	7	18	M18x1.5	69	1/8	90	13	12	M14x1.5
80	-300	37	40	50	25	40	3	20	20	89	M10x1.5 Depth 22	11	22	M22x1.5	80	1/8	108	—	—	—
100	-300	37	40	60	30	50	3	20	20	110	M12x1.75 Depth 22	11	26	M26x1.5	100	1/8	108	—	—	—

Bore (mm)	Without gaiter	
	H	Z
20	35	106
25	40	111
32	40	113
40	50	130
50	58	150
63	58	150
80	71	182
100	71	182

*Trunnion mounting threads in flats NA are not available for ∅80, ∅100 bores

DIMENSIONS
AIR CUSHION TYPE CDG1BA

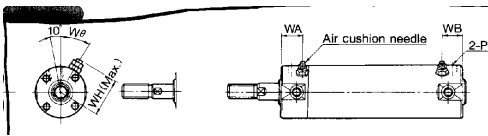

Bore (mm)	P	WA	WB	WH	WØ
20	M5x0.8	14	14	23	30°
25	M5x0.8	14	14	25	30°
32	1/8	14	13	28.5	25°
40	1/8	15	14	33	20°
50	1/4	16	15	40.5	20°
63	1/4	16	15	47.5	20°
80	3/8	22	22	60.5	20°
100	1/2	22	22	71	20°

DIMENSIONS
FLANGE MOUNT (CAN BE FITTED TO EITHER END OF CYLINDER)

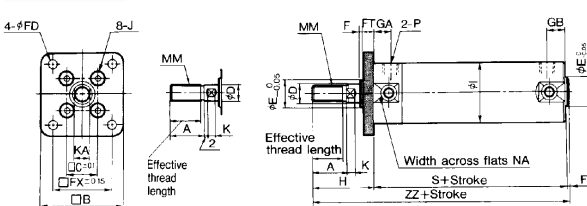

Bore (mm)	Stroke range (mm)	Effective thread length	A	□B	□C	∅D	∅E	GA	GB	∅I	J	K	KA	MM	* NA	P	S
20	-200	15.5	18	40	14	8	12	12	12	26	M4x0.7	4	6	M8x1.25	24	1/8	69
25	-300	19.5	22	44	16.5	10	14	12	12	31	M5x0.8	5	8	M10x1.25	29	1/8	69
32	-300	19.5	22	53	20	12	18	12	11	38	M5x0.8	5.5	10	M10x1.25	36	1/8	71
40	-300	27	30	61	26	16	25	13	12	47	M6x1	6	14	M14x1.5	44	1/8	78
50	-300	32	35	76	32	20	30	14	13	58	M8x1.25	7	18	M18x1.5	55	1/8	90
63	-300	32	35	92	38	20	32	14	13	72	M10x1.5	7	18	M18x1.5	69	1/8	90
80	-300	37	40	104	50	25	40	20	20	89	M10x1.5	11	22	M22x1.5	80	1/8	108
100	-300	37	40	128	60	30	50	20	20	110	M12x1.75	11	26	M26x1.5	100	1/8	108

*Trunnion mounting threads in flats NA are not available for ∅80, ∅100 bores

Bore (mm)	F	□FX	∅FD	FT	H	ZZ
20	2	28	5.5	6	35	106
25	2	32	5.5	7	40	111
32	2	38	6.6	7	40	113
40	2	46	6.6	8	50	130
50	2	58	9	9	58	150
63	2	70	11	9	58	150
80	3	82	11	11	71	182
100	3	100	14	14	71	182



FOR FURTHER TECHNICAL
DETAILS ON THIS
PRODUCT REQUEST
CATALOGUE REFERENCE
E216

DIMENSIONS FOOT MOUNT

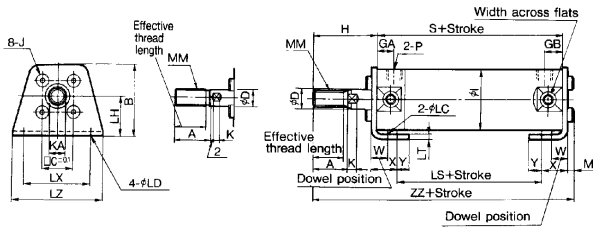

Bore (mm)	Stroke range (mm)	Effective thread length	A	□C	∅D	GA	GB	∅I	J	K	KA	M	MM	*NA	P	S	W	X	Y	∅LC	∅LD	LH	LS	LT	LX	LZ	H	ZZ
20	-200	15.5	18	14	8	12	12	26	M4x0.7	4	6	3	M8x1.25	24	7/8	69	10	15	7	4	5.5	20	45	3	32	44	35	110
25	-300	19.5	22	16.5	10	12	12	31	M5x0.8	5	8	3.5	M10x1.25	29	7/8	69	10	15	7	4	5.5	22	45	3	36	49	40	115.5
32	-300	19.5	22	20	12	12	11	38	M5x0.8	5.5	10	3.5	M10x1.25	36	7/8	71	10	16	8	4	6.6	25	45	3	44	58	40	117.5
40	-300	27	30	26	16	13	12	47	M6x1	6	14	4	M14x1.5	44	7/8	78	10	16.5	9	4	6.6	30	51	3	54	71	50	135
50	-300	32	35	32	20	14	13	58	M8x1.25	7	18	5	M18x1.5	55	7/8	90	17.5	22	11	5	9	40	55	4.5	66	86	58	157.5
63	-300	32	35	38	20	14	13	72	M10x1.5	7	18	5	M18x1.5	69	7/8	90	17.5	22	13	5	11	45	55	4.5	82	106	58	157.5
80	-300	37	40	50	25	20	20	89	M10x1.5	11	22	5	M22x1.5	80	7/8	108	20	28.5	14	6	11	55	60	4.5	100	125	71	188.5
100	-300	37	40	60	30	20	20	110	M12x1.75	11	26	7	M26x1.5	100	7/8	108	20	30	16	6	14	65	60	6	120	150	71	192

*Trunion mounting threads in flats NA are not available for ∅80, ∅100 bores

DIMENSIONS TRUNNION (CAN ALSO BE FITTED TO NOSE END OF CYLINDER)

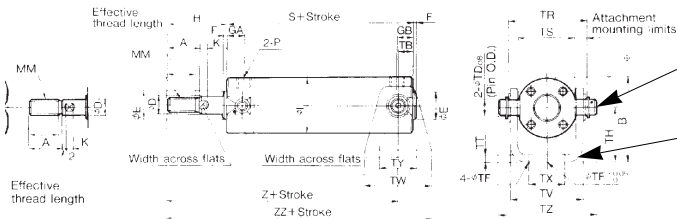

Trunion bolt set CG-T**
consists of Pin
Flat Washer
Hexagon Bolt

Receiving pivot bracket CG - ***-24A

Bore (mm)	Stroke range (mm)	Effective thread length	A	B	∅D	∅E	F	GA	GB	∅I	K	KA	MM	NA	P	S	TB	∅TDe8	∅TE	∅TF
20	-200	15.5	18	38	8	12	2	12	12	26	4	6	M8x1.25	24	7/8	69	11	8 ^{-0.025} _{-0.047}	10	5.5
25	-300	19.5	22	45.5	10	14	2	12	12	31	5	8	M10x1.25	29	7/8	69	11	10 ^{-0.025} _{-0.047}	10	5.5
32	-300	19.5	22	54	12	18	2	12	11	38	5.5	10	M10x1.25	36	7/8	71	10	12 ^{-0.032} _{-0.059}	10	6.6
40	-300	27	30	63.5	16	25	2	13	12	47	6	14	M14x1.5	44	7/8	78	10	14 ^{-0.032} _{-0.059}	10	6.6
50	-300	32	35	79	20	30	2	14	13	58	7	18	M18x1.5	55	7/8	90	12	16 ^{-0.032} _{-0.059}	20	9
63	-300	32	35	96	20	32	2	14	13	72	7	18	M18x1.5	69	7/8	90	12	18 ^{-0.032} _{-0.059}	20	11

Bore (mm)	TH	TR	TS	TT	TV	TW	TX	TY	TZ	H	Z	ZZ
20	25	39	28	3.2	35.8	42	16	28	47.6	35	93	114
25	30	43	33	3.2	39.8	42	20	28	53	40	98	119
32	35	54.5	40	4.5	49.4	48	22	28	67.7	40	101	125
40	40	65.5	49	4.5	58.4	56	30	30	78.7	50	118	146
50	50	80	60	6	72.4	64	36	36	98.6	58	136	168
63	60	98	74	8	90.4	74	46	46	119.2	58	136	173

MORE DIMENSIONS
SEE NEXT PAGE



SEE INSIDE FRONT COVER FOR
DETAILS OF YOUR LOCAL SALES OFFICE



FOR FURTHER TECHNICAL
DETAILS ON THIS
PRODUCT REQUEST
CATALOGUE REFERENCE
E216

DIMENSIONS

CLEVIS (SEE ACCESSORIES FOR RECEIVING PIVOT BRACKET) Ø20-63

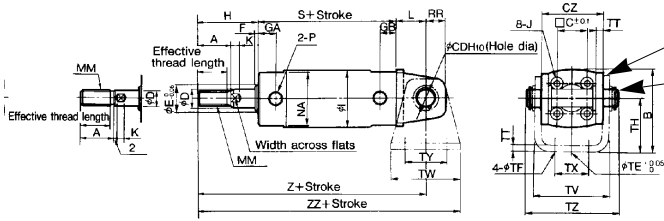

Rear Clevis CG - D **
Consists of Bracket
Pivot Pin

Receiving Pivot Bracket CG** - 24A

Ø80-Ø100

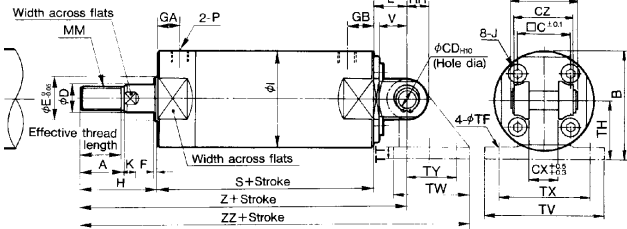

Bore (mm)	V	øTE	øTF	TH	TT	TV	TW	TX	TY	TZ	H	Z	ZZ
20	—	10	5.5	25	3.2	35.8	42	16	28	43.4	35	118	139
25	—	10	5.5	30	3.2	39.8	42	20	28	48	40	125	146
32	—	10	6.6	35	4.5	49.4	48	22	28	59.4	40	131	155
40	—	10	6.6	40	4.5	58.4	56	30	30	71.4	50	150	178
50	—	20	9	50	6	72.4	64	36	36	86	58	173	205
63	—	20	11	60	8	90.4	74	46	46	105.4	58	178	215
80	25	—	11	55	11	110	72	85	45	64	71	214	272.5
100	31	—	13.5	65	12	130	93	100	60	72	71	222	298.5

Bore (mm)	Stroke range (mm)	Effective thread length	A	□B	□C	ØD	ØE	F	GA	GB	ØI	J	K	K A	MM	NA	P	S	øCDH10	CX	CZ	L	RR
20	-200	15.5	18	38	14	8	12	2	12	12	26	M4x0.7	4	6	M8x1.5	24	1/8	69	8 ^{+0.058} ₀	—	29	14	11
25	-300	19.5	22	45.5	16.5	10	14	2	12	12	31	M5x0.8	5	8	M10x1.25	29	1/8	69	10 ^{+0.058} ₀	—	33	16	13
32	-300	19.5	22	54	20	12	18	2	12	11	38	M5x0.8	5.5	10	M10x1.25	36	1/8	71	12 ^{-0.070} ₀	—	40	20	15
40	-300	27	30	63.5	26	16	25	2	13	12	47	M6x1	6	14	M14x1.5	44	1/8	78	14 ^{+0.070} ₀	—	49	22	18
50	-300	32	35	79	32	20	30	2	14	13	58	M8x1.25	7	18	M18x1.5	55	1/4	90	16 ^{+0.070} ₀	—	60	25	20
63	-300	32	35	96	38	20	32	2	14	13	72	M10x1.5	7	18	M18x1.5	69	1/4	90	18 ^{-0.070} ₀	—	74	30	22
80	-300	37	40	99.5	50	25	40	3	20	20	89	M10x1.5	11	22	M22x1.5	80	3/8	108	18 ^{+0.070} ₀	28	56	35	18
100	-300	37	40	120	60	30	50	3	20	20	110	M12x1.75	11	26	M26x1.5	100	1/2	108	22 ^{+0.084} ₀	32	64	43	22

DIMENSIONS RUBBER CUSHION TYPE LONG STROKE CG1BN

Bore (mm)	Stroke range (mm)	Effective thread length	A	□C	□D	∅E	F	GA	∅I	J
20	191 - 350	15.5	18	14	8	12	2	12	26	M4x0.7 depth 7
25	291 - 400	19.5	22	16.5	10	14	2	12	31	M5x0.8 depth 7.5
32	289 - 450	19.5	22	20	12	18	2	12	38	M5x0.8 depth 8
40	285 - 800	27	30	26	16	25	2	13	47	M6x1 depth 12
50	285 - 1200	32	35	32	20	30	2	14	58	M8x1.25 depth 16
63	284 - 1200	32	35	38	20	32	2	14	72	M10x1.5 depth 16
80	284 - 1400	37	40	50	25	40	3	20	89	M10x1.5 depth 22
100	284 - 1500	37	40	60	30	50	3	20	110	M12x1.75 depth 22

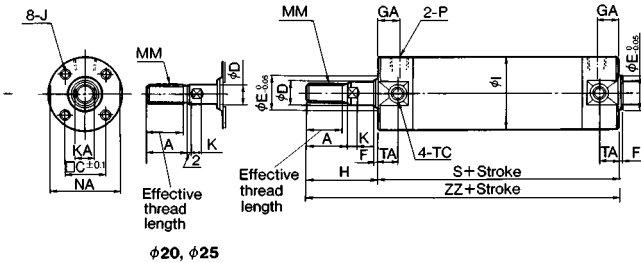

Bore (mm)	K	KA	MM	NA	P	S	TA	**TC	H	ZZ
20	4	6	M8x1.25	24	1/8	77	11	M5x0.8	35	114
25	5	8	M10x1.25	29	1/8	77	11	M6x0.75	40	119
32	5.5	10	M10x1.25	36	1/8	79	11	M8x1.0	40	121
40	6	14	M14x1.5	44	1/8	87	12	M10x1.25	50	139
50	7	18	M18x1.5	55	1/8	102	13	M12x1.25	58	162
63	7	18	M18x1.5	69	1/8	102	13	M14x1.5	58	162
80	11	22	M22x1.5	80	1/8	122	-	-	71	196
100	11	26	M26x1.5	100	1/8	122	-	-	71	196

**Tunnion mounting threads in flats NA are not available for ∅80, ∅100 bores.

DIMENSIONS AIR CUSHION TYPE LONG STROKE CG1BA

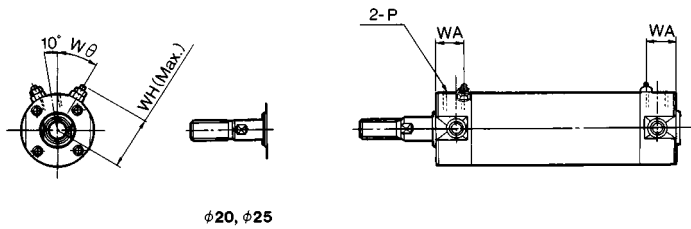

AIR CUSHION TYPE

Bore (mm)	P	WA	WH	Wθ
20	M5x0.8	14	23	30°
25	M5x0.8	14	25	30°
32	1/8	14	28.5	25°
40	1/8	15	33	20°
50	1/8	16	40.5	20°
63	1/8	16	47.5	20°
80	1/8	22	60.5	20°
100	1/8	22	71	20°

For those dimensions not shown please refer to Rubber Cushion Type.

DIMENSIONS FLANGE MOUNT (CAN BE FITTED TO EITHER END OF CYLINDER)

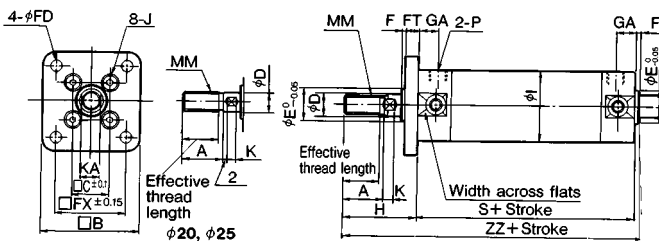

Bore (mm)	Stroke range (mm)	Effective thread length	A	□B	□C	∅D	∅E	F	□FX	∅FD	FT	GA
20	191 - 350	15.5	18	40	14	8	12	2	28	5.5	6	12
25	291 - 400	19.5	22	44	16.5	10	14	2	32	5.5	7	12
32	289 - 450	19.5	22	53	20	12	18	2	38	6.6	7	12
40	285 - 400	27	30	61	26	16	25	2	46	6.6	8	13
50	285 - 1200	32	35	76	32	20	30	2	58	9	9	14
63	284 - 1200	32	35	92	38	20	32	2	70	11	9	14
80	284 - 1400	37	40	104	50	25	40	3	82	11	11	20
100	284 - 1500	37	40	128	60	30	50	3	100	14	14	20

Bore (mm)	∅I	J	K	KA	MM	*NA	P	S	H	ZZ
20	26	M4x0.7	4	6	M8x1.25	24	1/8	77	35	114
25	31	M5x0.8	5	8	M10x1.25	29	1/8	77	40	119
32	38	M5x0.8	5.5	10	M10x1.25	36	1/8	79	40	121
40	47	M6x1	6	14	M14x1.5	44	1/8	87	50	139
50	58	M8x1.25	7	18	M18x1.5	55	1/4	102	58	162
63	72	M10x1.5	7	18	M18x1.5	69	1/4	102	58	162
80	89	M10x1.5	11	22	M22x1.5	80	3/8	122	71	196
100	110	M12x1.75	11	26	M26x1.5	100	1/2	122	71	196



SEE INSIDE FRONT COVER FOR
DETAILS OF YOUR LOCAL SALES OFFICE



FOR FURTHER TECHNICAL
DETAILS ON THIS
PRODUCT REQUEST
CATALOGUE REFERENCE
E216

DIMENSIONS FOOT MOUNT

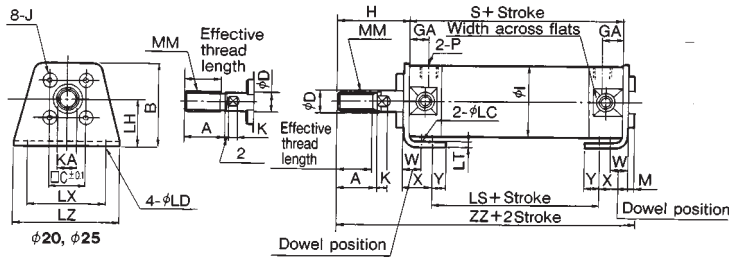

Bore (mm)	Stroke range (mm)	Eff. thread length	A	B	□C	ØD	GA	ØI	J	K	KA	M
20	191 - 350	15.5	18	34	14	8	12	26	M4x0.7	4	6	3
25	291 - 400	19.5	22	38.5	16.5	10	12	31	M5x0.8	5	8	3.5
32	289 - 450	19.5	22	45	20	12	12	38	M5x0.8	5.5	10	3.5
40	285 - 400	27	30	54.5	26	16	13	47	M5x0.8	6	14	4
50	285 - 1200	32	35	70.5	32	20	14	58	M6x1	7	18	5
63	284 - 1200	32	35	82.5	38	20	14	72	M8x1.25	7	18	5
80	284 - 1400	37	40	101	50	25	20	89	M8x1.25	11	22	5
100	284 - 1500	37	40	101	60	30	20	110	M12x1.75	11	26	7

MM	*NA	P	S	W	X	Y	ØLC	ØLD	LH	LS	LT	LX	LZ	H	ZZ
M8x1.25	24	1/8	77	10	15	7	4	5.5	20	53	3	32	44	35	118
M10x1.25	29	1/8	77	10	15	7	4	5.5	22	53	3	36	49	40	123.5
M10x1.25	36	1/8	79	10	16	8	4	6.6	25	53	3	44	58	40	125.5
M14x1.5	44	1/8	87	10	16.5	9	4	6.6	30	60	3	54	71	50	144
M18x1.5	55	1/4	102	17.5	22	11	5	9	40	67	4.5	66	86	58	169.5
M18x1.5	69	1/4	102	17.5	22	13	5	11	45	67	4.5	82	106	58	169.5
M22x1.5	80	1/8	122	20	28.5	14	6	11	55	74	4.5	100	125	71	202.5
M26x1.5	100	1/2	122	20	30	16	6	14	65	74	6	120	150	71	206

DIMENSIONS CLEVIS (SEE ACCESSORIES FOR RECEIVING PIVOT BRACKET)

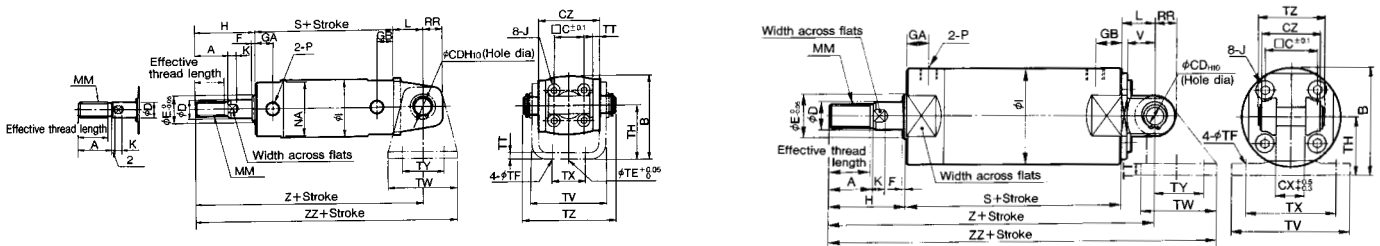

Bore (mm)	Stroke range (mm)	Effective thread length	A	B	□C	ØD	ØE	F	GA	GB	ØI	J	K	KA	MM	NA	P	S	ØCDH10
20	191 - 350	15.5	18	38	14	8	12	2	12	12	26	M4X0.7	4	6	M8X1.5	24	1/8	7	8 ^{+0.058}
25	291 - 400	19.5	22	45.5	16.5	10	14	2	12	12	31	M5X0.8	5	8	M10X1.25	29	1/8	7	10 ^{+0.058}
32	289 - 450	19.5	22	54	20	12	18	2	12	12	38	M5X0.8	5.5	10	M10X1.25	36	1/8	7	10 ^{+0.070}
40	285 - 800	27	30	63.5	26	16	25	2	13	13	47	M6X1	6	14	M14X1.5	44	1/8	7	10 ^{+0.070}
50	285 - 1200	32	35	79	32	20	30	2	14	14	58	M8X1.25	7	18	M18X1.5	55	1/4	7	10 ^{+0.070}
63	284 - 1200	32	35	96	38	20	32	2	14	14	72	M10X1.5	7	18	M18X1.5	69	1/4	7	10 ^{+0.070}
80	284 - 1400	37	40	99.5	50	25	40	3	20	20	89	M10X1.5	11	22	M22X1.5	80	1/8	7	10 ^{+0.070}
100	284 - 1500	37	40	120	60	30	50	3	20	20	110	M12X1.75	11	26	M26X1.5	100	1/2	7	10 ^{+0.08}

Bore (mm)	CX	CZ	L	RR	V	ØTE	ØTF	TH	TT	TV	TW	TX	TY	TZ	Without gaiter	Applicable Pin
20	-	29	14	11	-	10	5.5	25	3.2	35.8	42	16	28	43.4	35 126 147	CD-G02
25	-	33	16	13	-	10	5.5	30	3.2	39.8	42	20	28	48	40 133 154	CD-G25
32	-	40	20	15	-	10	6.6	35	4.5	49.4	48	22	28	59.4	40 139 163	CD-G03
40	-	49	22	18	-	10	6.6	40	4.5	58.4	56	30	30	71.4	50 159 187	CD-G04
50	-	60	25	20	-	20	9	50	6	72.4	64	36	36	86	58 185 217	CD-G05
63	-	74	30	22	-	20	11	60	8	90.4	74	46	46	1.5.4	58 190 227	CD-G06
80	28	56	35	18	25	-	11	55	11	110	72	85	45	64	71 228 286.5	IY-G08
100	32	64	43	22	31	-	13.5	65	12	130	93	100	60	72	71 236 312.5	IY-G10



SEE INSIDE FRONT COVER FOR
DETAILS OF YOUR LOCAL SALES OFFICE



FOR FURTHER TECHNICAL
DETAILS ON THIS
PRODUCT REQUEST
CATALOGUE REFERENCE
E216

DIMENSIONS AIR CUSHION TYPE DOUBLE ROD CG1WBA

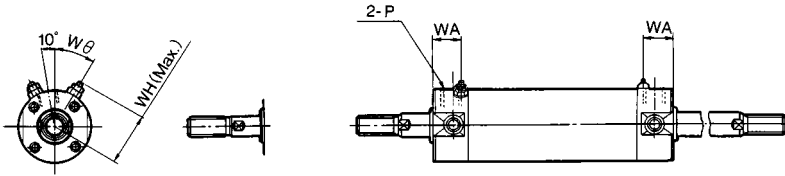

Bore (mm)	P	WA	WH	Wθ
20	M5x0.8	14	23	30°
25	M5x0.8	14	25	30°
32	1/8	14	28.5	25°
40	1/8	15	33	20°
50	1/4	16	40.5	20°
63	1/4	16	47.5	20°
80	3/8	22	60.5	20°
100	1/2	22	71	20°

DIMENSIONS FLANGE MOUNT (CAN BE FITTED TO EITHER END OF CYLINDER) DOUBLE ROD CYLINDER

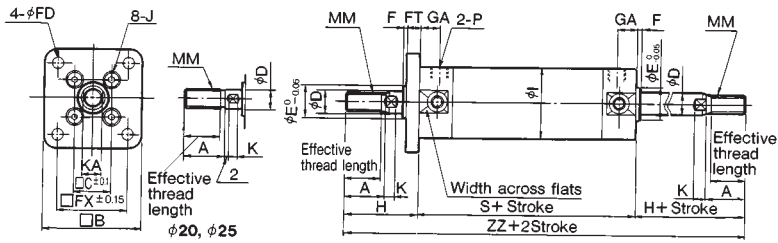

Bore (mm)	Stock range (mm)	Effective thread length	A	B	C	∅D	E	F	FX	FD	FT	GA
20	~200	15.5	18	40	14	8	12	2	28	5.5	6	12
25	~300	19.5	22	44	16.5	10	14	2	32	5.5	7	12
32	~300	19.5	22	53	20	12	18	2	38	6.6	7	12
40	~300	27	30	61	26	16	25	2	46	6.6	8	13
50	~300	32	35	76	32	20	30	2	58	9	9	14
63	~300	32	35	92	38	20	32	2	70	11	9	14
80	~300	37	40	104	50	25	40	3	82	11	11	20
100	~300	37	40	128	60	30	50	3	100	14	14	20

Bore (mm)	∅I	J	K	KA	MM	*NA	P	S	H	Z
20	26	M4x0.7	4	6	M8x1.25	24	1/8	77	35	147
25	31	M5x0.8	5	8	M10x1.25	29	1/8	77	40	157
32	38	M5x0.8	5.5	10	M10x1.25	36	1/8	79	40	159
40	47	M6x1	6	14	M14x1.5	44	1/8	87	50	187
50	58	M8x1.25	7	18	M18x1.5	55	1/4	102	58	218
63	72	M10x1.5	7	18	M18x1.5	69	1/4	102	58	218
80	89	M10x1.5	11	22	M22x1.5	80	1/2	122	71	264
100	110	M12x1.75	11	26	M26x1.5	100	1/2	122	71	264

*Trunnion mounting threads in flats NA are not available for ∅80, ∅100 bores.

DIMENSIONS FOOT MOUNT DOUBLE ROD CYLINDER

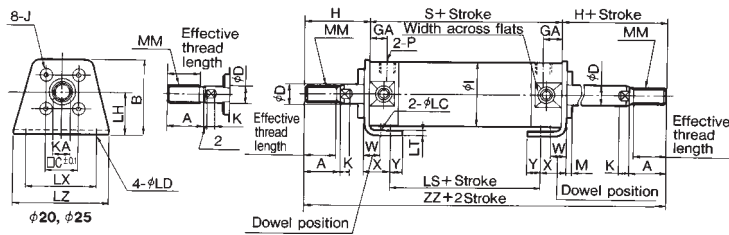

Bore (mm)	Stock range (mm)	Effective thread length	A	B	C	∅D	GA	∅I	J	K	KA	M
20	~200	15.5	18	34	14	8	12	26	M4x0.7	4	6	3
25	~300	19.5	22	38.5	16.5	10	12	31	M5x0.8	5	8	3.5
32	~300	19.5	22	45	20	12	12	38	M5x0.8	5.5	10	3.5
40	~300	27	30	54.5	26	16	13	47	M6x1	6	14	4
50	~300	32	35	70.5	32	20	14	58	M8x1.25	7	18	5
63	~300	32	35	82.5	38	20	14	72	M10x1.5	7	18	5
80	~300	37	40	101	50	25	20	89	M10x1.5	11	22	5
100	~300	37	40	101	60	30	20	110	M12x1.75	11	26	7

*Trunnion mounting threads in flats NA are not available for ∅80, ∅100 bores.

Bore (mm)	MM	*NA	P	S	W	X	Y	∅LC	∅LD	LH	LS	LT	LX	LZ	Without gaiter ZZ
20	M8x1.25	24	1/8	77	10	15	7	4	5.5	20	53	3	32	44	35
25	M10x1.25	29	1/8	77	10	15	7	4	5.5	22	53	3	36	49	40
32	M10x1.25	36	1/8	79	10	16	8	4	6.6	25	53	3	44	58	40
40	M14x1.5	44	1/8	87	10	16.5	9	4	6.6	30	60	3	54	71	50
50	M18x1.5	55	1/4	102	17.5	22	11	5	9	40	67	4.5	66	86	58
63	M18x1.5	69	1/4	102	17.5	22	13	5	11	45	67	4.5	82	106	58
80	M22x1.5	80	3/8	122	20	28.5	14	6	11	55	74	4.5	100	125	71
100	M26x1.5	100	1/2	122	20	30	16	6	14	65	74	6	120	150	71



SEE INSIDE FRONT COVER FOR
DETAILS OF YOUR LOCAL SALES OFFICE



FOR FURTHER TECHNICAL
DETAILS ON THIS
PRODUCT REQUEST
CATALOGUE REFERENCE
E216

DIMENSIONS

TRUNNION (CAN BE FITTED TO EITHER END OF CYLINDER)
DOUBLE ROD CYLINDER

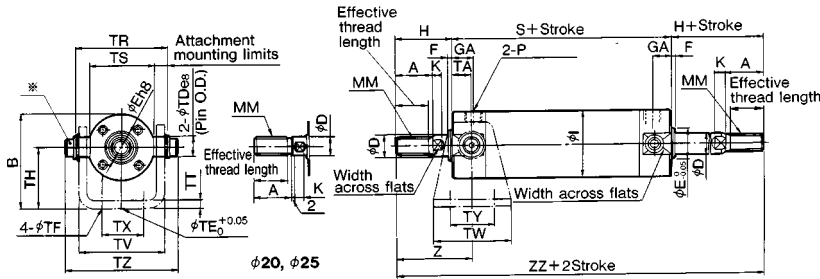

*Consists of pin, flat washer, and hexagon socket cap bolt

Bore (mm)	Stock range (mm)	Effective thread length	A	B	ØD	E	F	GA	ØI	K	KA	MM	NA	P	S
20	~200	15.5	18	38	8	12	2	12	26	4	6	M8x1.25	24	1/8	77
25	~300	19.5	22	45.5	10	14	2	12	31	5	8	M10x1.25	29	1/8	77
32	~300	19.5	22	54	12	18	2	12	38	5.5	10	M10x1.25	36	1/8	79
40	~300	27	30	63.5	16	25	2	13	47	6	14	m14x1.5	44	1/8	87
50	~300	32	35	79	20	30	2	14	58	7	18	M18x1.5	55	1/4	102
63	~300	32	35	96	20	32	2	14	72	7	18	M18x1.5	69	1/4	102

Bore (mm)	TA	ØTDe8	ØTE	ØTF	TH	TR	TS	TT	TV	TW	TX	TY	TZ	Without gaiter		
														H	Z	ZZ
20	11	8 ^{+0.025} _{-0.047}	10	5.5	25	39	28	3.2	35.8	42	16	28	47.6	35	46	147
25	11	10 ^{+0.025} _{-0.057}	10	5.5	30	43	33	3.2	39.8	42	20	28	53	40	51	157
32	11	12 ^{+0.035} _{-0.065}	10	6.6	35	54.5	40	4.5	49.4	48	22	28	67.7	40	51	159
40	12	14 ^{+0.032} _{-0.059}	10	6.6	40	65.5	49	4.5	58.4	56	30	30	78.7	50	62	187
50	13	16 ^{+0.035} _{-0.065}	20	9	50	80	60	6	72.4	64	36	36	98.6	58	71	218
63	13	18 ^{+0.035} _{-0.065}	20	11	60	98	74	8	90.4	74	46	46	119.2	58	71	218

DIMENSIONS

SINGLE ROD CLEVIS

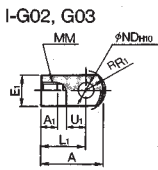

Material: Rolled steel

I-G04, G05, G08, G10

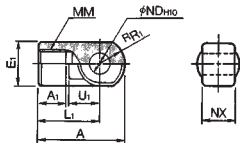

Material: Cast iron

Part no	Applicable bore (mm)	A	A1	E1	L1	MM	RR1	U1	ND _{H10}	NX
I-G02	20	34	8.5	□16	25	M8x1.25	10.3	11.5	8 ^{+0.058} ₀	8 ^{-0.2} _{-0.4}
I-G03	25, 32	41	10.5	□20	30	M10x1.25	12.8	14	10 ^{+0.058} ₀	10 ^{-0.2} _{-0.4}
I-G04	40	42	14	Ø20	30	M14x1.5	12	14	10 ^{+0.058} ₀	18 ^{-0.3} _{-0.5}
I-G05	50, 63	56	18	Ø28	40	M18x1.5	16	20	14 ^{+0.070} ₀	22 ^{-0.3} _{-0.5}
I-G08	80	71	21	Ø38	50	M22x1.5	21	27	18 ^{+0.070} ₀	28 ^{-0.3} _{-0.5}
I-G10	100	79	21	Ø44	55	M26x1.5	24	31	22 ^{+0.084} ₀	32 ^{-0.3} _{-0.5}

DIMENSIONS

ACCESSORIES

PISTON ROD BALL JOINT DIN 648

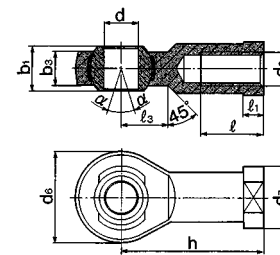

Bore size	Model	Thread d ₃	d _{H7}	h	d ₆	b ₃	b ₁	l	d ₇	α°	l ₃
Ø20	KJ8D	M8	8	36	24	9	12	16	16	13	12
Ø25	KJ10D	M10x1.25	10	43	28	10.5	14	20	19	13	14
Ø32	KJ10D	M10x1.25	10	43	28	10.5	14	20	19	13	14



DIMENSIONS FLOATING JOINT/SERIES JA

JA20-30

JA20-30

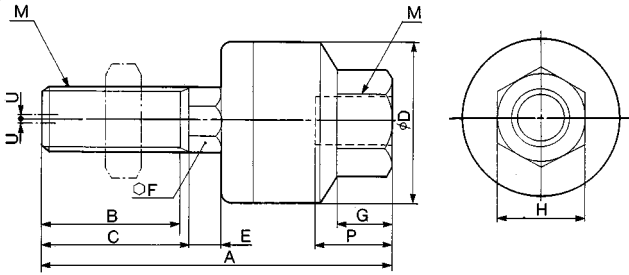

Cylinder Bore (mm)	Part No.	M	A	B	C	D	E	F	G	H	Thread depth	Allowable eccentricity Umm	Max. angular misalignment	Max. Compressive (kN)	Mass (kg)
Ø20	JA20-8-125	M8 x 1.25	44	17.5	-	21	4.5	7	7	13	8	0.5	±5°	2.5	0.07
Ø25	JA30-10-125	M10 x 1.25	49.5	19.5	-	24	5	8	8	17	9	0.5	±5°	2.5	0.07
Ø32	JA30-10-125	M10 x 1.25	49.5	19.5	-	24	5	8	8	17	9	0.5	±5°	2.5	0.07

DIMENSIONS DOUBLE ROD CLEVIS

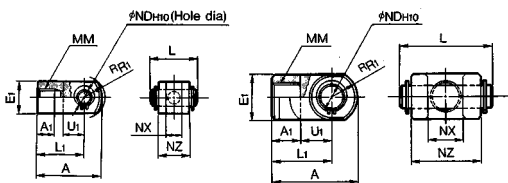

Part no	Applicable bore (mm)	A	A1	E1	L1	MM	RR1	U1	NDH10	NX	NZ	L	Applicable retaining pin
Y-G02	20	34	8.5	□16	25	M8x1.25	10.3	11.5	8 ^{+0.058} / ₀	8 ^{+0.4} / _{-0.2}	16	21	IY-G02
Y-G03	25, 32	41	10.5	□20	30	M10x1.25	12.8	14	10 ^{+0.058} / ₀	10 ^{+0.4} / _{-0.2}	20	25.6	IY-G03
Y-G04	40	42	16	Ø20	30	M14x1.5	12	14	10 ^{-0.058} / ₀	18 ^{+0.5} / _{-0.3}	36	41.6	IY-G04
Y-G05	50, 63	56	20	Ø28	40	M18x1.5	16	20	14 ^{+0.070} / ₀	22 ^{+0.5} / _{-0.3}	44	50.6	IY-G05
Y-G08	80	71	23	Ø38	50	M22x1.5	21	27	18 ^{+0.070} / ₀	28 ^{+0.5} / _{-0.3}	56	64	IY-G08
Y-G10	100	79	24	Ø44	55	M26x1.5	24	31	22 ^{+0.084} / ₀	32 ^{+0.5} / _{-0.3}	64	72	IY-G10

DIMENSIONS ROD JOINT PIN

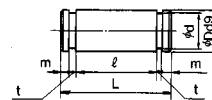

Material: Carbon steel

Part no	Applicable bore (mm)	ØDd9	L	Ød	l	m	t	Applicable retaining pin
IY-G02	20	8 ^{-0.040} / _{-0.076}	21	7.6	16.2	1.5	0.9	C-8 type for pivot
IY-G03	25, 32	10 ^{-0.040} / _{-0.076}	25.6	9.6	20.2	1.55	1.15	C-10 type for pivot
IY-G04	40	10 ^{-0.040} / _{-0.076}	41.6	9.6	36.2	1.55	1.15	C-10 type for pivot
IY-G05	50, 63	14 ^{-0.050} / _{-0.093}	50.6	13.4	44.2	2.05	1.15	C-14 type for pivot
IY-G08	80	18 ^{-0.050} / _{-0.093}	64	17	56.2	2.55	1.35	C-18 type for pivot
IY-G10	100	22 ^{-0.055} / _{-0.177}	72	21	64.2	2.55	1.35	C-22 type for pivot



SEE INSIDE FRONT COVER FOR
DETAILS OF YOUR LOCAL SALES OFFICE



FOR FURTHER TECHNICAL
DETAILS ON THIS
PRODUCT REQUEST
CATALOGUE REFERENCE
E216

DIMENSIONS

CLEVIS PIN (INCLUDED WITH CLEVIS, CIRCLIPS NOT SHOWN)

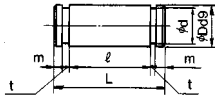

Material: Carbon steel

Part no	Applicable bore (mm)	φDd9	L	φd	l	m	t	Applicable retaining pin
CD-G02	20	8 ^{-0.040} / _{-0.076}	43.4	7.6	38.6	1.5	0.9	C-8 type for pivot
CD-G25	25	10 ^{-0.040} / _{-0.075}	48	9.6	42.6	1.55	1.15	C-10 type for pivot
CD-G03	32	12 ^{-0.050} / _{-0.093}	59.4	11.5	54	1.55	1.15	C-12 type for pivot
CD-G04	40	14 ^{-0.050} / _{-0.093}	71.4	13.4	65	2.05	1.15	C-14 type for pivot
CD-G05	50	16 ^{-0.050} / _{-0.093}	86	15.2	79.6	2.05	1.15	C-16 type for pivot
CD-G06	63	18 ^{-0.050} / _{-0.093}	105.4	17	97.8	2.45	1.35	C-18 type for pivot

DIMENSIONS ROD END NUT

NT-G02, G03

NT-G04, G05
NT-08, 10

Material:
Rolled steel



Part no	Applicable bore (mm)	d	H	B	C	D
NT-02	20	M8x1.25	5	13	15.0	12.5
NT-03	25, 32	M10x1.25	6	17	19.6	16.5
NT-04	40	M14x1.5	8	22	24.5	21.0
NT-05	50, 63	M18x1.5	11	27	31.2	26
NT-08	80	M22x1.5	13	32	37.0	31
NT-10	100	M26x1.5	16	41	47.3	39

DIMENSIONS TRUNNION BRACKET

φ20~φ63

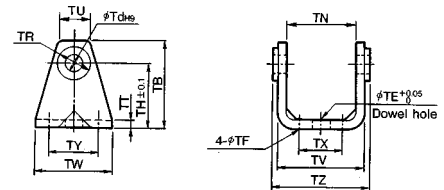

Material: Rolled steel

φ80~φ100

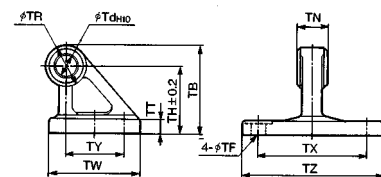

Part no	Applicable bore (mm)	TB	φTd	φTE	φTF	TH	TN
CG-020-24A	20	36	8 ^{-0.036} / ₀	10	5.5	25	29 ^{+0.4} / _{-0.1}
CG-025-24A	25	43	10 ^{-0.036} / ₀	10	5.5	30	33 ^{+0.4} / _{-0.1}
CG-032-24A	32	50	12 ^{-0.043} / ₀	10	6.6	35	40 ^{+0.5} / _{-0.1}
CG-040-24A	40	58	14 ^{-0.043} / ₀	10	6.6	40	49 ^{+0.5} / _{-0.1}
CG-050-24A	50	70	16 ^{-0.043} / ₀	20	9	50	60 ^{+0.5} / _{-0.1}
CG-063-24A	63	82	18 ^{-0.043} / ₀	20	11	60	74 ^{+0.7} / _{-0.1}
CG-080-24A	80	73	18 ^{-0.070} / ₀	—	11	55	28 ^{-0.1} / _{-0.3}
CG-100-24A	100	90	22 ^{-0.084} / ₀	—	13.5	65	32 ^{-0.1} / _{-0.3}

Part no	Applicable bore (mm)	φTR	TT	TU	TV	TW	TX	TY	TZ
CG-020-24A	20	13	3.2	18.1	35.8	42	16	28	38
CG-025-24A	25	15	3.2	20.7	39.8	42	20	28	42
CG-032-24A	32	17	4.5	23.6	49.4	48	22	28	53.4
CG-040-24A	40	21	4.5	27.3	58.4	56	30	30	64.4
CG-050-24A	50	24	6	29.7	72.4	64	36	36	78.8
CG-063-24A	63	26	8	34.3	90.4	74	46	46	96.6
CG-080-24A	80	36	11	—	—	72	85	45	110
CG-100-24A	100	50	12	—	—	93	100	60	130

