

# Plug Crimp Attachment for Flexible Cable and Direct Solder for Semi-Rigid Cable

## Straight Crimp Plug - Captive Contact - Plenum Cable

P.N.	Cable Group	Plt.	Ins.	Imp.	Crimp Tool
B1121CA-001-ND3G-4A-75	04A	Nickel	Delrin	75	4

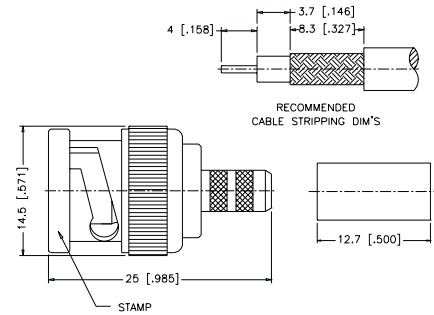

Assembly Instruction J - page 218

## Straight Crimp Plug - Captive Contact - Miniature Cable

P.N.	Cable Group	Plt.	Ins.	Imp.	Crimp Tool
<b>Brass Shell</b>					
B1121E1-002-ND3G-5-50	05	Nickel	Delrin	50	3
B1121E1-ND3G-5A-50	05A	Nickel	Delrin	50	3
B1121E1-ND3G-6-50	06	Nickel	Delrin	50	3
B1121E2-003-ND3G-6-75	06	Nickel	Delrin	75	3
B1121E1-ND3G-6A-75	06A	Nickel	Delrin	75	9
B1121H1-001-ND3G-14-50	14	Nickel	Delrin	50	9
B1121A1-ND3G-16-75	16	Nickel	Delrin	75	1 or 2
B1121A9-010-NT30G-16-75*	16	Nickel	Teflon	75	3
<b>Diecast Shell</b>					
B1121FA-001-ND3G-5-50	05	Nickel	Delrin	50	3
B1121FA-001-ND3G-6-50	06	Nickel	Delrin	50	3

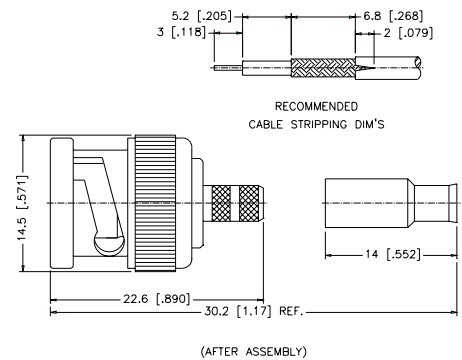

Assembly Instruction K - page 219

Remark: With teflon sleeve/Hex crimp size: 178°

\* Center contact .053" diameter, 30 μ" Au.  
True 75 ohm. Use .044 hex or 12-indent crimp

## Straight Solder Plug - Semi-Rigid Cable

P.N.	Cable Group	Plt.	Ins.	Imp.	Crimp Tool
B1181A1-N/3GT3G-10-50	10	Nickel/Gold	Teflon	50	N/A
B1181A1-N/NT30GA-10-75	10	Nickel/Gold	Teflon	75	N/A
B1181A1-NT3G-11-50	11	Nickel/Gold	Teflon	50	N/A



B1181A1-N/3GT3G-10-50

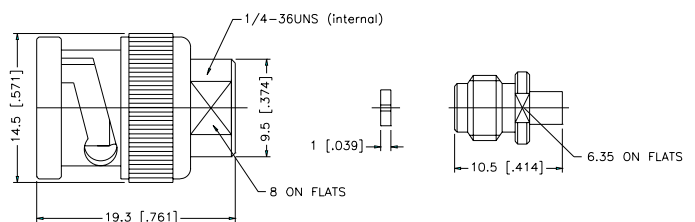
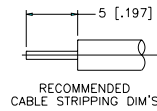
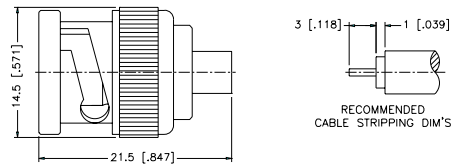

B1181A1-N/NT30GA-10-75

Assembly Instruction E - page 213