

1			2			3			4			5			6			7			8		
REVISIONS																							
ISS	ZONE	DESCRIPTION\PER REQUEST\DATE																					

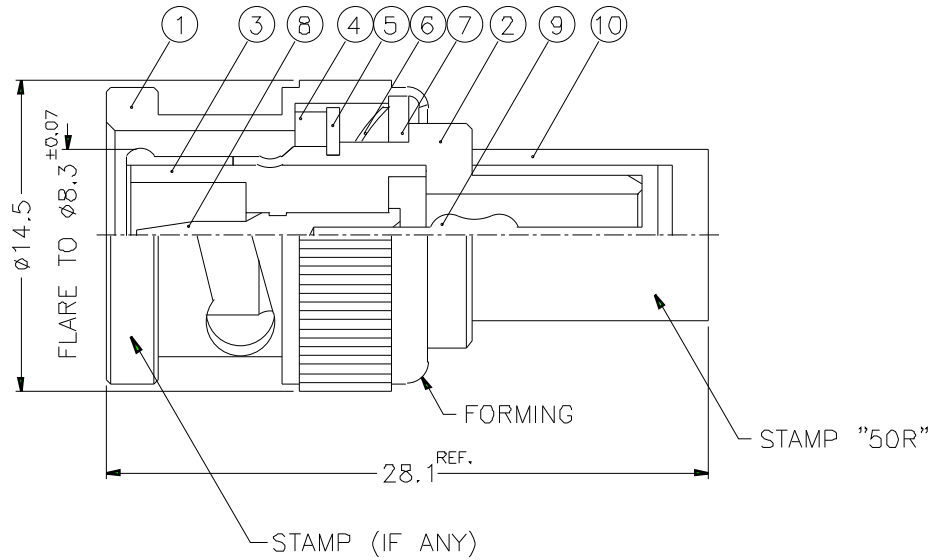

NOTES: FINISH (PLATING THICKNESS IN MICRO-INCHES)
 1. BRASS PER QQ-B-626
 2. BRASS PER QQ-B-613
 3. NICKEL PL. 100 MIN. THICK OVER COPPER STRIKE
 4. NICKEL PL. 200 MIN. THICK OVER COPPER STRIKE
 5. GOLD PL. 3 MIN. THICK OVER NICKEL PL. 100 MIN. THICK OVER COPPER STRIKE

10	PARTS	NOTE 1	NOTE 3	1	B5209-10
9	RESISTOR	50R		1	RS-50R-1W-1%
8	CONTACT PIN	NOTE 1	NOTE 5	1	B1004A1-8-3/08WS
7	WASHER	NOTE 2	NOTE 3	1	WS-128/9X0B
6	SPRING	SK5	NOTE 4	1	B50000-6
5	RETAINER RING	NOTE 1	NOTE 3	1	B50000-5
4	GASKET	RUBBER	RED	1	GS-115/8X15
3	INSULATOR	DELRIIN	NATURAL	1	B50000-3-50-A
2	BODY	NOTE 1	NOTE 3	1	B50000-2-56/39
1	SHELL	NOTE 1	NOTE 3	1	B50000-1-B
NO.	DESCRIPTION	MATERIAL	FINISH	Q'TY	DRAWING NO.

DIMENSIONS ARE IN MILLIMETERS			PART NO.		
UNLESS OTHERWISE SPECIFIED TOLERANCES			B1004A1-ND3G-50R-0.01-1W		
0.5-6 = ±0.2			APPROVED		
6-30 = ±0.4			DATE		
30-120 = ±0.6			10-11-01'		
120-315 = ±1			CHECKED		
315-1000 = ±1.6			DATE		
1000-2000 = ±2.4			10-11-01'		
DRAWN			DATE		
10-11-01'					

Amphenol	
TITLE	BNC TERMINATOR PLUG
DRAWING NO.	KJ-B1004A1-ND3G-50R-0.01-1W
ITEM NO.	

1	2	3	4	5	6	7	8
---	---	---	---	---	---	---	---