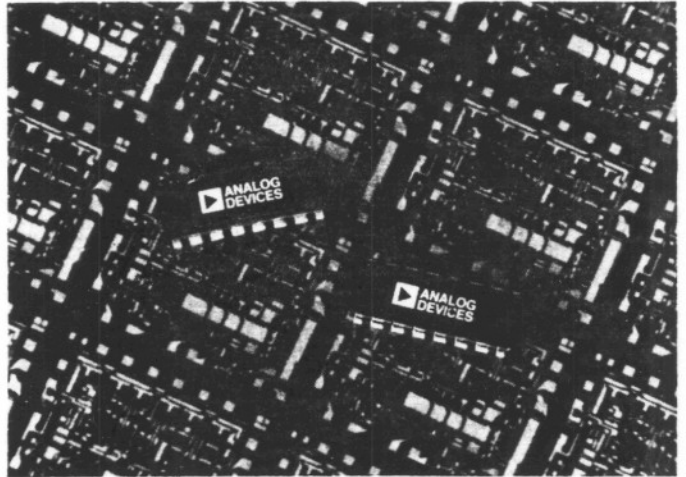

FEATURES

- Improved Replacement for Industry Standard 1408/1508
- Improved Settling Time: 250ns typ
- Improved Linearity: $\pm 0.1\%$ Accuracy Guaranteed Over Temperature Range (-9 Grade)
- High Output Voltage Compliance: +0.5V to -5.0V
- Low Power Consumption: 157mW typ
- High Speed 2-Quadrant Multiplying Input: 4.0mA/ μ s Slew Rate
- Single Chip Monolithic Construction
- Hermetic 16 Pin Ceramic DIP
- Low Cost

**PRODUCT DESCRIPTION**

The AD1408 and AD1508 are low cost monolithic integrated circuit 8-bit multiplying digital-to-analog converters, consisting of matched bipolar switches, a precision resistor network and a control amplifier. The single chip is mounted in a hermetically sealed ceramic 16 lead dual-in-line package.

Advanced circuit design and precision processing techniques result in significant performance advantages over older industry standard 1408/1508 devices. The maximum linearity error over the specified operating temperature range is guaranteed to be less than $\pm \frac{1}{4}$ LSB (-9 grade) while settling time to $\pm \frac{1}{4}$ LSB is reduced to 250ns typ. The temperature coefficient of gain is typically 20ppm/ $^{\circ}$ C and monotonicity is guaranteed over the entire operating temperature range.

The AD1408/AD1508 is recommended for all low-cost 8-bit DAC requirements; it is also suitable for upgrading overall performance where older, less accurate and slower 1408/1508 devices have been designed in. The AD1408 series is specified for operation over the 0 to +75 $^{\circ}$ C temperature range, the AD1508 series for operation over the entire military temperature range of -55 $^{\circ}$ C to +125 $^{\circ}$ C.

PRODUCT HIGHLIGHTS

1. Monolithic IC construction makes the AD1408/AD1508 an optimum choice for applications where low cost is a major consideration.
2. The AD1408/AD1508 directly replaces other devices of this type.
3. Versatile design configuration allows voltage or current outputs, variable or fixed reference inputs, CMOS or TTL logic compatibility and a wide choice of accuracy and temperature range specifications.
4. Accuracies within $\pm \frac{1}{4}$ LSB allow performance improvement of older applications without redesign.
5. Faster settling time (250ns typ) permits use in higher speed applications.
6. Low power consumption improves stability and reduces warm-up time.
7. The AD1408/AD1508 multiplies in two quadrants when a varying reference voltage is applied. When multiplication is not required, a fixed reference is used.
8. The AD1408/AD1508 is available in chip form; please consult factory for details.
9. The device is packaged in a hermetically-sealed ceramic 16 lead dual-in-line package. Processing to MIL-STD-883 level B is available.

SPECIFICATIONS

(typical @ +25°C and $V_{CC} = +5.0V$ dc, $V_{EE} = -15V$ dc unless otherwise noted)

MAXIMUM RATINGS

| RATING | SYMBOL | VALUE | UNIT |
|---|---------------------|------------------|----------------|
| POWER SUPPLY VOLTAGE | V_{CC} | +5.5 | V dc |
| | V_{EE} | -16.5 | V dc |
| DIGITAL INPUT VOLTAGE | V_5 thru V_{12} | +5.5, 0 | V dc |
| APPLIED OUTPUT VOLTAGE | V_O | +0.5, -5.2 | V dc |
| REFERENCE CURRENT | I_{14} | 5.0 | mA |
| REFERENCE AMPLIFIER INPUTS | V_{14}, V_{15} | V_{CC}, V_{EE} | V dc |
| POWER DISSIPATION (Package Limitation) Derate above $T_A = +25^\circ C$ | P_D | 1000 | mW |
| | | 6.7 | mW/°C |
| OPERATING TEMPERATURE RANGE | AD1408 Series | T_A | 0 to +75 °C |
| | AD1508 Series | T_A | -55 to +125 °C |
| STORAGE TEMPERATURE RANGE | T_{STG} | -65 to +150 | °C |

ELECTRICAL CHARACTERISTICS

($V_{CC} = +5.0V$ dc, $V_{EE} = -15V$ dc, $V_{REF} = 2.0mA$, AD1508 Series: $T_A = -55^\circ C$ to +125°C
AD1408 Series: $T_A = 0$ to +75°C unless otherwise noted. All digital inputs at high logic level.)

| CHARACTERISTIC | SYMBOL | MIN | TYP | MAX | UNIT |
|--|--------------------|------|------|------------|--------|
| RELATIVE ACCURACY (Error Relative to Full Scale I_O) | | | | | |
| AD1508-9, AD1408-9 | E_T | - | - | ±0.10 | % |
| AD1508-8, AD1408-8 | E_T | - | - | ±0.19 | % |
| AD1408-7 | E_T | - | - | ±0.39 | % |
| SETTLING TIME to Within 1/2LSB [Includes t_{PLH}] ($T_A = +25^\circ C$) | t_S | - | 250 | - | ns |
| PROPAGATION DELAY TIME $T_A = +25^\circ C$ | t_{PLH}, t_{PHL} | - | 30 | 100 | ns |
| OUTPUT FULL SCALE CURRENT DRIFT | T_{CI_O} | - | -20 | - | ppm/°C |
| DIGITAL INPUT LOGIC LEVELS (MSB) | | | | | |
| High Level, Logic "1" | V_{IH} | 2.0 | - | - | V dc |
| Low Level, Logic "0" | V_{IL} | - | - | 0.8 | V dc |
| DIGITAL INPUT CURRENT (MSB) | | | | | |
| High Level, $V_{IN} = 5.0V$ | I_{IH} | - | 0 | 0.04 | mA |
| Low Level, $V_{IL} = 0.8V$ | I_{IL} | - | -0.4 | -0.8 | mA |
| REFERENCE INPUT BIAS CURRENT (Pin 15) | I_{15} | - | -1.0 | -3.0 | μA |
| OUTPUT CURRENT RANGE | | | | | |
| $V_{EE} = -5.0V$ | I_{OR} | 0 | 2.0 | 2.1 | mA |
| $V_{EE} = -6.0V$ to -15V | I_{OR} | 0 | 2.0 | 4.2 | mA |
| OUTPUT CURRENT $V_{REF} = 2.000V, R_{14} = 1000\Omega$ | I_O | 1.9 | 1.99 | 2.1 | mA |
| OUTPUT CURRENT (All Bits Low) | I_O (min) | - | 0 | 4.0 | μA |
| OUTPUT VOLTAGE COMPLIANCE ($E_1 \leq 0.19\%$ at $T_A = +25^\circ C$) | | | | | |
| $V_{EE} = -5V$ | V_O | - | - | -0.6, +0.5 | V dc |
| V_{EE} below -10V | V_O | - | - | -5.0, +0.5 | V dc |
| REFERENCE CURRENT SLEW RATE | $SR_{I_{REF}}$ | - | 4.0 | - | mA/μs |
| OUTPUT CURRENT POWER SUPPLY SENSITIVITY | PSS_{I_O} | - | 0.5 | 2.7 | μA/V |
| POWER SUPPLY CURRENT (All Bits Low) | | | | | |
| | I_{CC} | - | +9 | +14 | mA |
| | I_{EE} | - | -7.5 | -13 | mA |
| POWER SUPPLY VOLTAGE RANGE ($T_A = +25^\circ C$) | | | | | |
| | V_{CCR} | +4.5 | +5.0 | +5.5 | V dc |
| | V_{EER} | -4.5 | -15 | -16.5 | V dc |
| POWER DISSIPATION | | | | | |
| All Bits Low | | | | | |
| $V_{EE} = -5.0V$ dc | P_D | - | 82 | 135 | mW |
| $V_{EE} = -15V$ dc | P_D | - | 157 | 265 | mW |
| All Bits High | | | | | |
| $V_{EE} = -5.0V$ dc | P_D | - | 70 | - | mW |
| $V_{EE} = -15V$ dc | P_D | - | 132 | - | mW |

Specifications subject to change without notice.

APPLYING THE AD1408/1508

Reference Amplifier Drive and Compensation

Figures 2a and 2b are the connection diagrams for using the AD1408/AD1508 in basic voltage output modes. In Figure 2a, a positive reference voltage, V_{REF} , is converted to a current by resistor R14. This reference current determines the scale factor for the output current such that the full scale output is 1LSB (1/256) less than the reference current. R15 provides bias current compensation to the reference control amplifier to minimize temperature drift; it is nominally equal to R14 although it needn't be a stable precision resistor. This configuration develops a negative output voltage across R_L and requires a positive V_{REF} .

If a negative V_{REF} is to be used, connections to the reference control amplifier must be reversed as shown in Figure 2b. This circuit also delivers a negative output voltage, but presents a high impedance to the reference source. The negative V_{REF} must be at least 4 volts above the V_{EE} supply.

Two quadrant multiplication may be performed by applying a bipolar ac signal as the reference as long as pin 14 is positive relative to pin 15 (reference current must flow into pin 14). If the ac reference is applied to pin 14 through R14, a negative voltage equal to the negative peak of the ac reference must be applied through R15 to pin 15; if the ac reference is applied to pin 15 through R15, a positive voltage equal to the positive peak of the ac reference must be applied through R14 to pin 14.

When a dc reference is used, capacitive bypass from reference to ground will improve noise rejection.

The compensation capacitor, C, provides proper phase margin for the reference control amplifier. As R14 is increased, the closed-loop gain of the amplifier is decreased, therefore C must be increased. For R14 = 1.0k Ω , 2.5k Ω and 5.0k Ω , minimum values of capacitance are 15pF, 37pF and 75pF respectively. C may be tied to either V_{EE} or ground, but tying it to V_{EE} increases negative noise rejection. If the reference is driven by a high-impedance current source, heavy compensation of the amplifier is required; this causes a reduction in overall bandwidth.

Output Current Range

The nominal value for output current range is 0 to 1.992mA as determined by a 2mA reference current. If V_{EE} is more negative than -7.0 volts, this range may be increased to a maximum of 0 to 4.2mA. An increase in speed may be realized at increased output current levels, but power consumption will increase, possibly causing small shifts in linearity.

Pin 1, range control, may be grounded or unconnected. Although other older devices of this type require different terminations for various applications, the AD1408/AD1508 compensates automatically. This pin is not connected internally, therefore any previously installed connections will be tolerated.

Output Voltage Range

The voltage on pin 4 is restricted to a +0.5 to -0.6 volt range when $V_{EE} = -5V$. When V_{EE} is more negative than -10 volts, this range is extended to +0.5 to -5.0 volts. If the current into pin 14 is 2mA (full-scale output current = 1.992mA), a 2.5k Ω resistor between the output, pin 4, and ground will provide a 0 to -4.980 volt full-scale. If R_L exceeds 500 Ω however, the settling time of the device is increased.

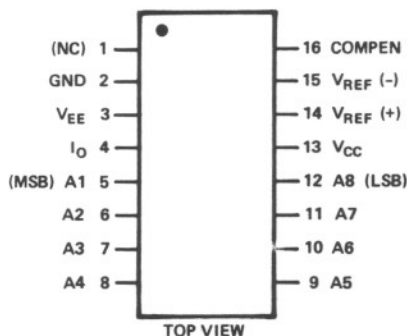
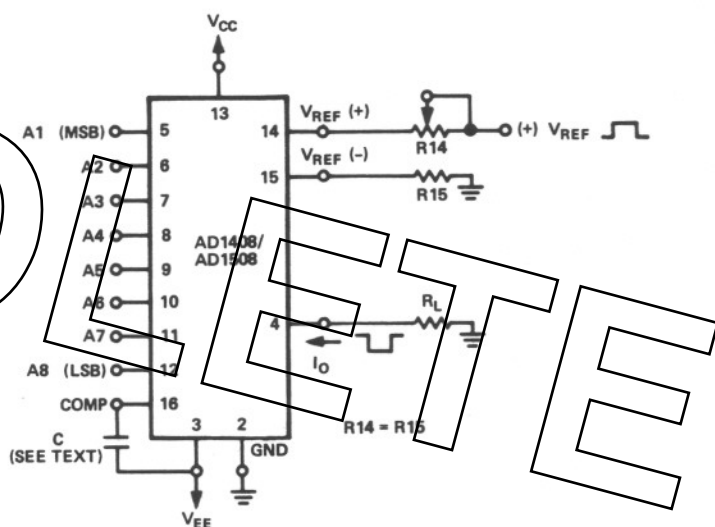
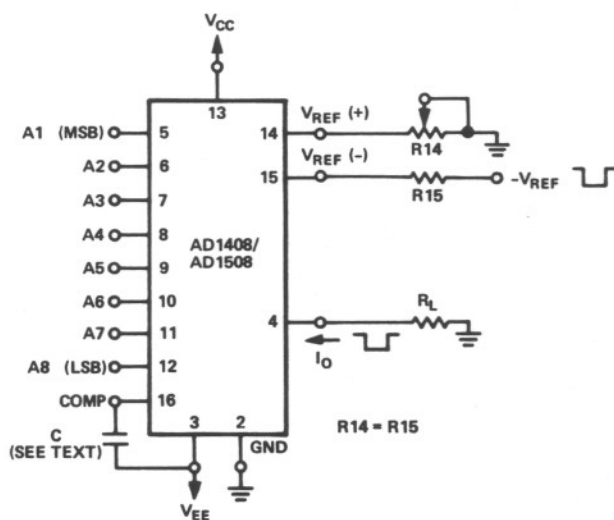

Figure 1. Pin Connections



a. Connections for Use with Positive Reference



b. Connections for Use with Negative Reference

Figure 2. Basic Connections

Voltage Output

A low impedance voltage output may be derived from the output current of the AD1408/AD1508 by using an output amplifier as shown in Figure 3. The output current I_O flows in R_O to create a positive-going voltage range at the output of amplifier A1. R_O may be chosen for the desired range of output voltage; the complete circuit transfer function is given in Figure 3.

If a bipolar output voltage range is desired, R_{BP} , shown dotted, must be installed. Its purpose is to provide an offset equal to one-half of full-scale at the output of A1. The procedure for calibrating the circuit of Figure 3 is as follows:

Calibration for Unipolar Outputs (No R_{BP})

1. With all bits "OFF", adjust the A1 null-pot, R1, for $V_{OUT} = 0.00V$.
2. With all bits "ON", adjust R_{REF} for $V_{OUT} = (\text{Nominal Full Scale}) - 1\text{LSB} = +9.961$ volts

Calibration for Bipolar Outputs (R_{BP} installed, R1 not required)

1. With all bits "OFF", adjust R_{BP} for $V_{OUT} = -F.S. = -5.000$ volts
2. With Bit 1 (MSB) "ON", and all other Bits "OFF", adjust R_{REF} for $V_{OUT} = 0.000V$.
3. With all bits "ON", verify that $V_{OUT} = +5.000V - 1\text{LSB} = 4.961V$.

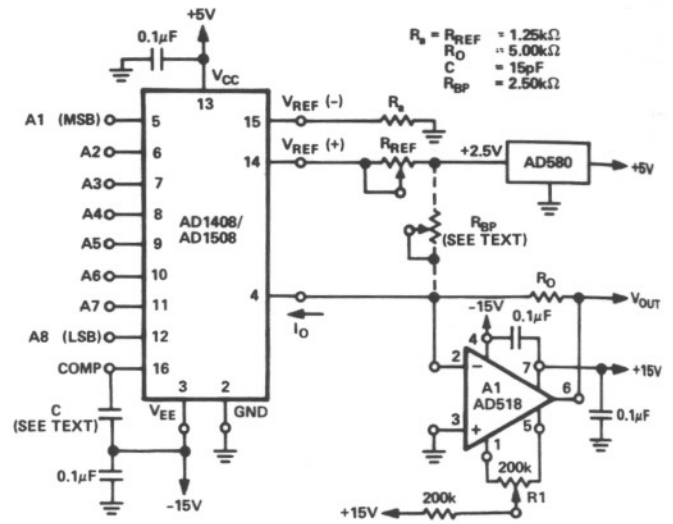

$$V_{OUT} = \frac{V_{REF}}{R_{REF}} (R_O) \left[\frac{A1}{2} + \frac{A2}{4} + \frac{A3}{8} + \frac{A4}{16} + \frac{A5}{32} + \frac{A6}{64} + \frac{A7}{128} + \frac{A8}{256} \right]$$

ADJUST V_{REF} , R_{REF} OR R_O SO THAT WITH ALL DIGITAL INPUTS AT LOGIC "1", $V_{OUT} = 9.961$ VOLTS:

$$V_{OUT} = \frac{2.5}{1.25k\Omega} (5k\Omega) \left[\frac{1}{2} + \frac{1}{4} + \frac{1}{8} + \frac{1}{16} + \frac{1}{32} + \frac{1}{64} + \frac{1}{128} + \frac{1}{256} \right] = 9.961 \text{ VOLTS}$$

Figure 3. Typical Connection Diagram, AD1408/AD1508, Voltage Output, Fixed Reference

OUTLINE DIMENSIONS

Dimensions shown in inches and (mm).

16-PIN DUAL-IN-LINE

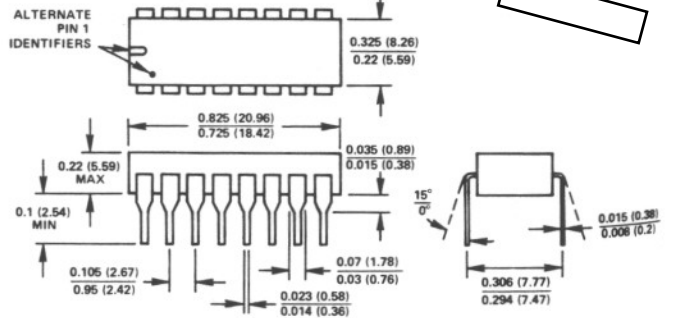
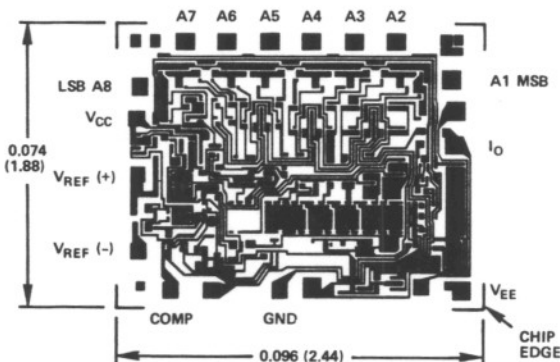

Figure 4. Simplified Block Diagram



THE AD1408/AD1508 IS AVAILABLE IN CHIP FORM GUARANTEED TO -7 LEVEL PERFORMANCE. CONSULT FACTORY FOR APPLICATION AND PRICING DETAILS.

Figure 5. Chip Dimensions and Pad Layout. Dimensions shown in inches and (mm).

AD1408/AD1508 ORDERING GUIDE

| MODEL | ACCURACY (±% F.S.) | TEMP. RANGE (°C) |
|--------------------|-----------------------|------------------------|
| AD1408-7D | 0.39 | 0 to +75 |
| AD1408-8D | 0.19 | 0 to +75 |
| AD1408-9D | 0.10 | 0 to +75 |
| AD1508-8D | 0.19 | -55 to +125 |
| AD1508-9D | 0.10 | -55 to +125 |
| AD1508-8D/ 883B | 0.19 | -55 to +125 |
| AD1508-9D/ 883B | 0.10 | -55 to +125 |