

TOSHIBA RF POWER AMPLIFIER MODULE

S-AV35

FM RF POWER AMPLIFIER MODULE for VHF MARINE BAND

- Output Power :32W (Min.)
- Power Gain :35.0dB (Min.)
- Total Efficiency:50% (Min.)

MAXIMUM RATINGS (Tc = 25 , ZG = ZL = 50)

CHARACTERISTIC	SYMBOL	TEST CONDITION	RATING	UNIT
DC Supply Voltage	V _{DD}	V _{GG} =0V, Pi =0mW	16.5	V
DC Supply Voltage	V _{DD}	V _{GG} 5V, Pi =50mW, Po 45W	16.5	V
DC Supply Voltage	V _{GG}	V _{DD} 12.5V, Pi =50mW	5.5	V
Total Current	I _T	V _{DD} 12.5V, Pi =50mW	8	A
Input Power	P _i	V _{DD} 12.5V, V _{GG} 5V	20	mW
Output Power	P _o	12.5V < V _{DD} 16.5V, V _{GG} 5V, Pi =50mW	45	W
Operating Case Temperature Range	T _{c (opr)}	V _{GG} 5V	-30~100	
Storage Temperature Range	T _{stg}		-40~110	

Caution: This maximum rating given in a sheet guarantees each item independently. When two items or more of maximum rated items joins a device at once. It becomes the outside of a guarantee. Please design in circuit to make it always operate within this regulation also on the worst condition.

PACKAGE OUTLINE

Unit in mm

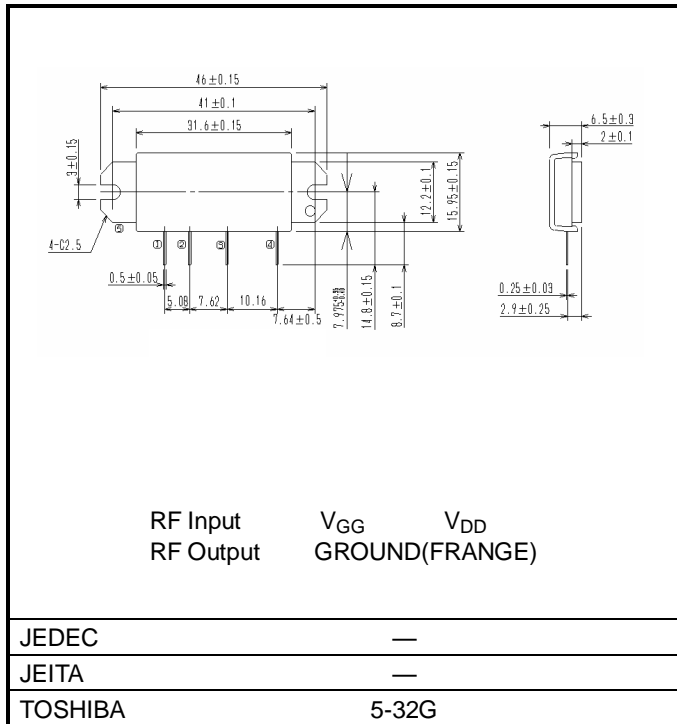

Weight: 11.8g

ELECTRICAL CHARACTERISTICS (T_c = 25 , Z_G = 50)

CHARACTERISTIC	SYMBOL	TEST CONDITION	MIN.	TYP.	MAX.	UNIT
Frequency Range	f _{range}	—	154	—	162	MHz
Output Power 1	P _{o1}	V _{DD} = 12.5V V _{GG} = 5V P _i = 10mW Z _L = 50	32	—	—	W
Power Gain 1	G _{p1}		35.0	—	—	dB
Total Efficiency	η _T		50	—	—	%
Input VSWR	VSWR _{in}		—	—	3.0	—
Second Harmonic	2nd HRM		—	—	-30	dB
Third Harmonic	3rd HRM		—	—	-30	dB
Output Power 2	P _{o2}	V _{DD} = 10.5V, V _{GG} = 5V P _i = 10mW, Z _L = 50	20	—	—	W
Power Gain 2	G _{p2}		33.0	—	—	dB
Load Mismatch	—	V _{DD} = 15V, P _i = 10mW P _o = 32W (V _{GG} = adjust, Z _L = 50) VSWR LOAD 10: 1 ALL PHASE (@2s)	No Degradation			—
Stability	—	V _{DD} = 10.5 to 16.5V, V _{GG} = 0 to 5V P _i = 10mW P _o = 32W (V _{GG} = adjust, Z _L = 50) VSWR LOAD 3: 1 ALL PHASE	All spurious output than 60dB below desired signal			—

Caution

- This product has intersetting cap. Please pay attention for exceeding stress and foreign matter in your application. And not to take away the cap.
- Do not break, cut, crush or dissolve chemically. Dispose of this product properly according to law. Do not intermingle with normal industrial or domestic waste.
- This product is electrostatic sensitivity, please handle with caution.
- This product is flowed high current for a VDD terminal at both RF ON and RF OFF. And it has large calorific value for high output power. So please use it within the limit of the maximum rating.
The view of the maximum rating of our company,
"The absolute maximum ratings are rated values which must not be exceeded during operation, even for an instant. And it guarantees each item independently. When two items or more of maximum rated items joins a device at once. It becomes the outside of a guarantee. "

SCHEMATIC

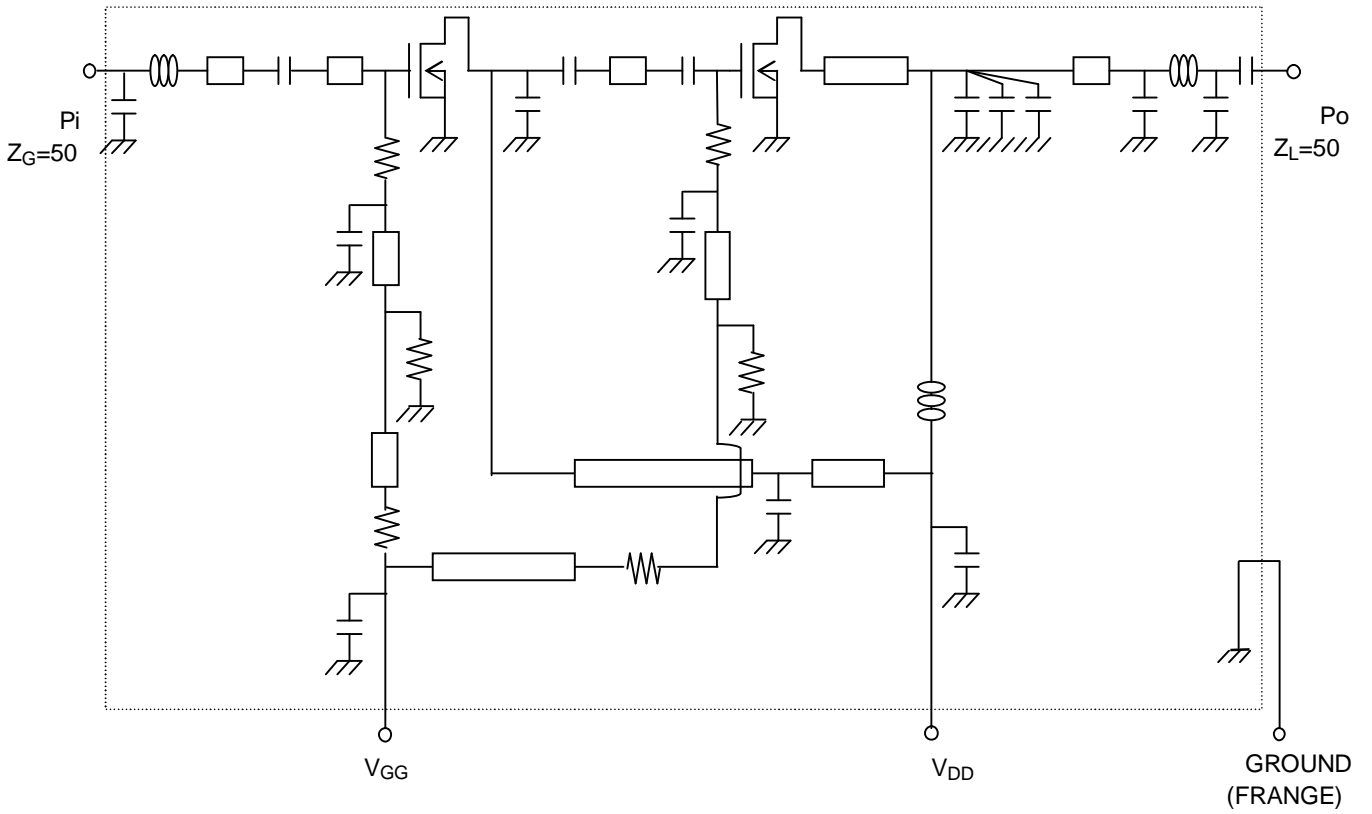

TEST FIXTURE

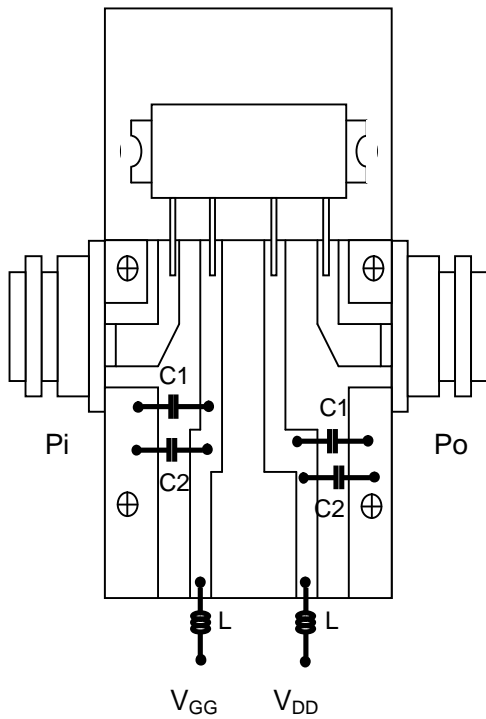

TYPICAL PERFORMANCE CURVE

Test Condition : $T_c=25$, $Z_g=Z_l=50\Omega$, unless otherwise specified

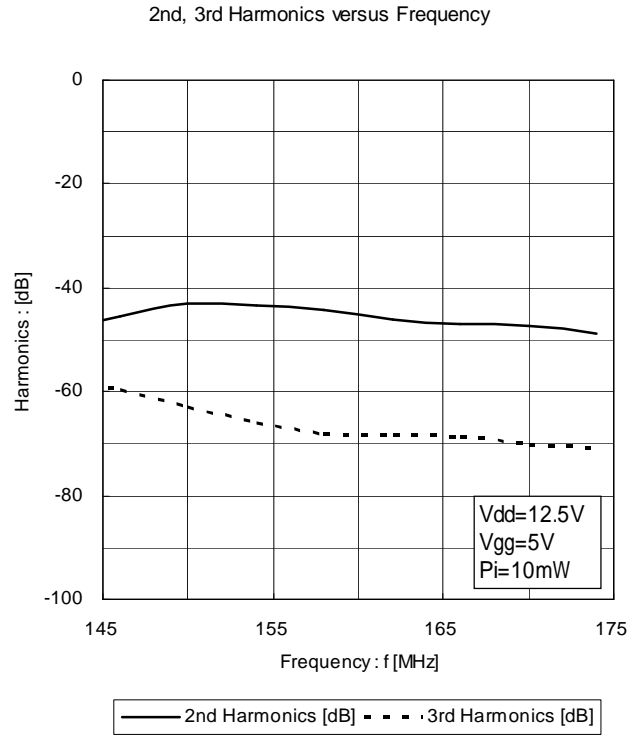
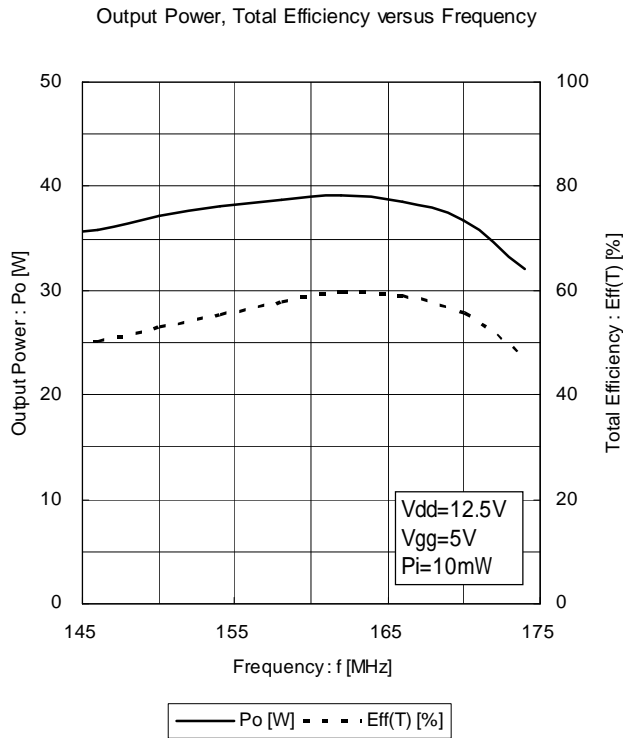

Output Power, Total Efficiency versus Gate Voltage

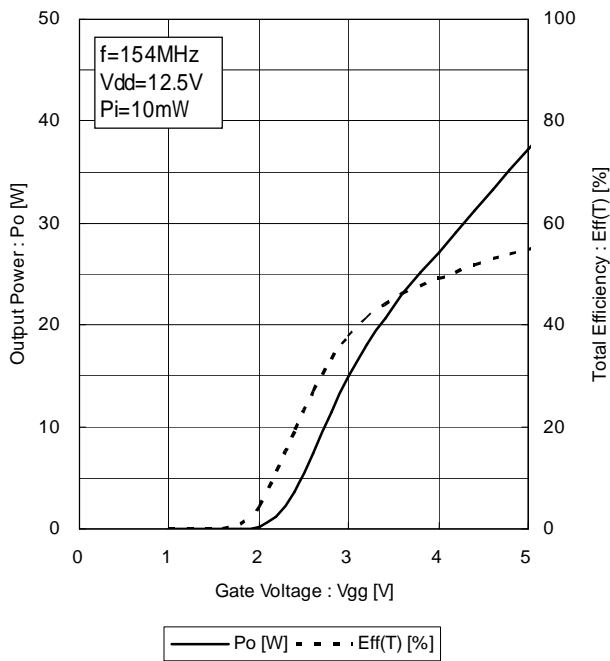

Output Power, Total Efficiency versus Gate Voltage

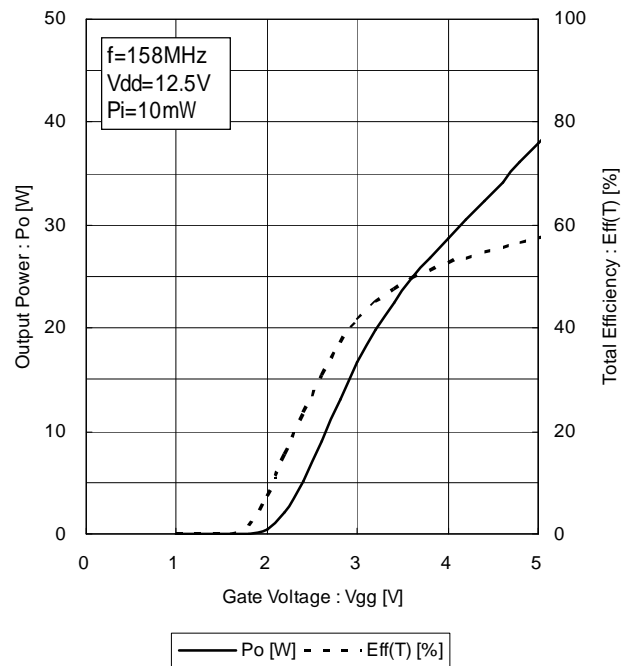

Output Power, Total Efficiency versus Gate Voltage

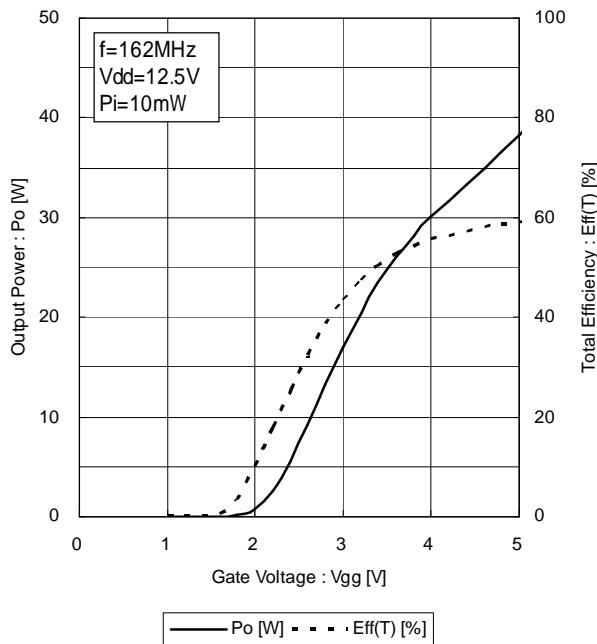

CAUTION

These are only typical curves and devices are not necessarily guaranteed at these curves.

RESTRICTIONS ON PRODUCT USE

030619EAA

- The information contained herein is subject to change without notice.
- The information contained herein is presented only as a guide for the applications of our products. No responsibility is assumed by TOSHIBA for any infringements of patents or other rights of the third parties which may result from its use. No license is granted by implication or otherwise under any patent or patent rights of TOSHIBA or others.
- TOSHIBA is continually working to improve the quality and reliability of its products. Nevertheless, semiconductor devices in general can malfunction or fail due to their inherent electrical sensitivity and vulnerability to physical stress. It is the responsibility of the buyer, when utilizing TOSHIBA products, to comply with the standards of safety in making a safe design for the entire system, and to avoid situations in which a malfunction or failure of such TOSHIBA products could cause loss of human life, bodily injury or damage to property.
In developing your designs, please ensure that TOSHIBA products are used within specified operating ranges as set forth in the most recent TOSHIBA products specifications. Also, please keep in mind the precautions and conditions set forth in the "Handling Guide for Semiconductor Devices," or "TOSHIBA Semiconductor Reliability Handbook" etc..
- The TOSHIBA products listed in this document are intended for usage in general electronics applications (computer, personal equipment, office equipment, measuring equipment, industrial robotics, domestic appliances, etc.). These TOSHIBA products are neither intended nor warranted for usage in equipment that requires extraordinarily high quality and/or reliability or a malfunction or failure of which may cause loss of human life or bodily injury ("Unintended Usage"). Unintended Usage include atomic energy control instruments, airplane or spaceship instruments, transportation instruments, traffic signal instruments, combustion control instruments, medical instruments, all types of safety devices, etc.. Unintended Usage of TOSHIBA products listed in this document shall be made at the customer's own risk.
- TOSHIBA products should not be embedded to the downstream products which are prohibited to be produced and sold, under any law and regulations.