

MG30G6EL2

GTR MODULE
SILICON NPN TRIPLE DIFFUSED TYPE

HIGH POWER SWITCHING APPLICATIONS.
MOTOR CONTROL APPLICATIONS.

FEATURES:

- The Collector is Isolation from Case.
- 6 Power Transistors and 6 Free Wheeling Diodes are Built Into 1 Package.
- High DC Current Gain : $h_{FE}=100(\text{Min.}) (I_C=30A)$
- Low Saturation Voltage
: $V_{CE(sat)}=2.0V(\text{Max.}) (I_C=30A)$
- High Speed : $t_f=3\mu s(\text{Max.}) (I_C=30A)$

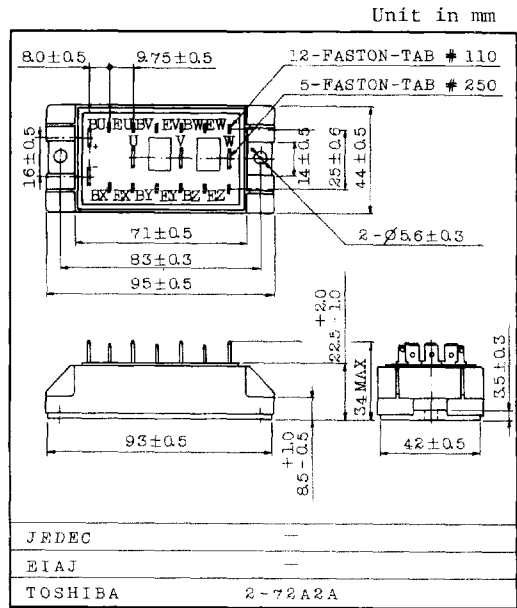

Weight : 240g

EQUIVALENT CIRCUIT

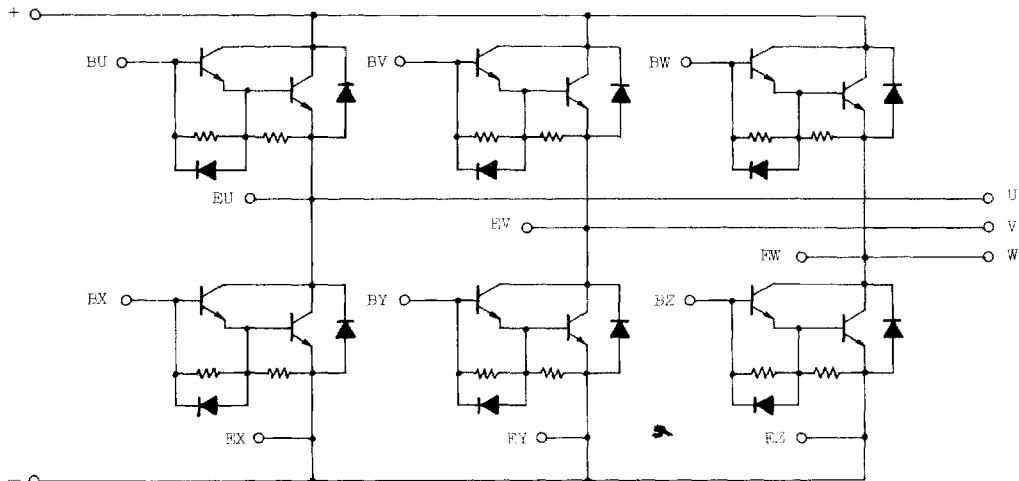

MAXIMUM RATINGS (Ta=25°C)

CHARACTERISTIC		SYMBOL	RATING	UNIT
Collector-Base Voltage		V _{CB0}	600	V
Collector-Emitter Sustaining Voltage		V _{CEX(SUS)}	600	V
		V _{CEO(SUS)}	450	
Emitter-Base Voltage		V _{EB0}	6	V
Collector Current	DC	I _C	30	A
	lms	I _{CP}	60	
Forward Current	DC	I _F	30	A
	lms	I _{FM}	60	
Base Current		I _B	2	A
Collector Power Dissipation (Tc=25°C)		P _C	200	W
Junction Temperature		T _j	150	°C
Storage Temperature Range		T _{stg}	-40~125	°C
Isolation Voltage		V _{isol}	2500 (AC 1 Minute)	V
Screw Torque			30	kg·cm

ELECTRICAL CHARACTERISTICS (Ta=25°C)

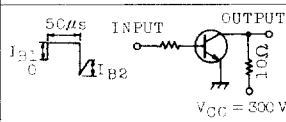
CHARACTERISTIC		SYMBOL	TEST CONDITION	MIN.	TYP.	MAX.	UNIT
Collector Cut-off Current		I _{CB0}	V _{CB} =600V, I _E =0	-	-	1.0	mA
Emitter Cut-off Current		I _{EB0}	V _{EB} =6V, I _C =0	-	-	200	mA
Collector-Emitter Sustaining Voltage		V _{CEO(SUS)}	I _C =0.5A, L=40mH	450	-	-	V
DC Current Gain		h _{FE}	V _{CE} =5V, I _C =30A	100	-	-	
Collector-Emitter Saturation Voltage		V _{CE(sat)}	I _C =30A, I _B =0.6A	-	-	2.0	V
Base-Emitter Saturation Voltage		V _{BE(sat)}		-	-	2.5	V
Switching Time	Turn-on Time	t _{on}	 <p>50µs INPUT OUTPUT I_{B1} I_{E2} I_C V_{CC} = 300V</p>	-	-	1.0	µs
	Storage Time	t _{stg}		-	-	12	
	Fall Time	t _f		I _{B1} =0.6A, I _{E2} =-0.6A DUTY CYCLE=0.5%	-	-	
Forward Voltage		V _F	I _F =30A, I _B =0	-	-	1.6	V
Reverse Recovery Time		t _{rr}	I _F =30A, V _{BE} =-2V di/dt=60A/µs	-	-	0.7	µs
Thermal Resistance		R _{th(j-c)}	Transistor	-	-	0.625	°C/W
			Diode	-	-	1.8	

MG30G6EL2

